







# AIR HANDLING UNITS









# AIR HANDLING UNITS WITH HEAT RECOVERY

## COUNTERFLOW HEAT RECOVERY UNITS IN EPP CASING

 	<b>VENTS Enave-C 100/120 P</b> <b>Air handling units with heat recovery and EC motor</b> Air flow – up to 156 m <sup>3</sup> /h	page 14
 	<b>VENTS Enave P</b> <b>Air handling units with heat recovery and EC motor</b> Air flow – up to 310 m <sup>3</sup> /h	page 20
 	<b>VENTS Enave-C P</b> <b>Air handling units with heat recovery and EC motor</b> Air flow – up to 279 m <sup>3</sup> /h	page 24
 	<b>VENTS Enave V</b> <b>Air handling units with heat recovery and EC motor</b> Air flow – up to 720 m <sup>3</sup> /h	page 30

## ROTARY HEAT RECOVERY UNITS

 	<b>Vents VUTR 202 V EC</b> <b>Air handling unit with heat recovery and EC motor</b> Air flow – up to 270 m <sup>3</sup> /h	page 40
 	<b>VENTS VUTR V EC</b> <b>Air handling unit with heat recovery and EC motor</b> Air flow – up to 747 m <sup>3</sup> /h	page 46
 	<b>VENTS VUTR P EC</b> <b>Air handling unit with heat recovery and EC motor</b> Air flow – up to 798m <sup>3</sup> /h	page 52



## COUNTERFLOW HEAT RECOVERY UNITS IN METAL CASING



**VENTS VUT PB EC**  
Air handling unit with heat recovery and EC motor  
Air flow – up to 410 m<sup>3</sup>/h

page  
60



**VENTS VUT VB EC/VENTS VUE VB EC**  
Air handling unit with heat recovery and EC motor  
Air flow – up to 690 m<sup>3</sup>/h

page  
64



**VENTS VUT/VUE HB EC/VENTS VUT/VUE HBE EC**  
Air handling unit with heat recovery and EC motor  
Air flow – up to 830 m<sup>3</sup>/h

page  
74



**VENTS VUT PBE EC/VENTS VUT PBW EC**  
Air handling unit with heat recovery and EC motor  
Air flow – up to 4300 m<sup>3</sup>/h

page  
82

## CROSSFLOW HEAT RECOVERY UNITS

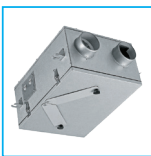

**VENTS VUT 80 P mini**  
Air handling unit with heat recovery  
Air flow – up to 70 m<sup>3</sup>/h

page  
92



**VENTS VUT/VUE 250 V mini/VUT/VUE 250 H mini**  
Air handling units with heat recovery  
Air flow – up to 250 m<sup>3</sup>/h

page  
94



**VENTS VUT V2/H2 mini EC, VENTS VUE V2/H2 mini EC**  
Air handling unit with heat recovery and EC motor  
Air flow – up to 300 m<sup>3</sup>/h

page  
96

## SUPPLY UNITS



### **VENTS MPA 300-700 E EC A31, VENTS MPA 1000-4000 E EC A31 series supply units**

Air flow – up to 5000 m<sup>3</sup>/h

page  
98



### **VENTS MPA 700 W EC A31, VENTS MPA 1000-4000 W EC A31 series supply units**

Air flow – up to 4950 m<sup>3</sup>/h

page  
106

## ACCESSORIES



Silencers  
**SR, SRF**

page  
116



Heaters  
**NKP A21 V.2, NKD A21 V.2**

page  
122



Hydraulic U-trap  
**SH-32**

page  
126



Dampers  
**KOM1**

page  
128

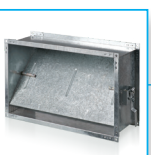

Air dampers  
**KR, KRV**

page  
129



Air flow controllers  
**RRV**

page  
132



Control panels  
**A22, A22 Wi-Fi, A25**

page  
134

## ACCESSORIES



Electro-mechanical humidistats  
**HV-2, HR-S**

page  
135



Electric actuator BELIMO  
**TF230/TF24**

page  
137



Duct temperature sensors with a terminal box  
**KDT-MK, KDT2-MK,**

page  
139



CO<sub>2</sub> sensors  
**CO2-1, CO2-2, CO2-3**

page  
140

# WELCOME TO THE WORLD OF VENTS!



- The company's product range includes over 50.000 items
- Over the years the company has produced 100 million fans
- The production facilities spread across 150.000 square meters of territory
- The company employs more than 3.500 professionals involved in the entire life cycle of creating ventilation equipment – from concept to high-tech product
- Among other assets the facilities include the climatic equipment research and development centre and a suite of state-of-the-art laboratories manned by 200 engineers
- The company utilises the latest metal and polymer processing technology
- 99 % of our products are made in-house
- We are the only company in the industry which develops and builds 85 % of its ventilation equipment components

Being the world's ventilation leader VENTS offers a wide range of cutting-edge ventilation equipment to satisfy most demanding customers. Since the inception, the company's products have become popular in more than 100 countries worldwide while the VENTS brand has earned a solid reputation for quality, reliability and innovation. Every tenth domestic fan in the world rolled off the assembly line of the VENTS factory. Every time you buy a product carrying the VENTS

brand you can be confident that you have made the right choice. Thanks to a comprehensive range of ventilation equipment for home, commercial and industrial applications you can always find the necessary equipment and components to suit your needs. The climatic engineering and design solutions department is tasked with developing bespoke ventilation and air conditioning systems for even the most challenging projects.

## Technology of the future

The VENTS factory is not just about state-of-the-art production lines equipped with processing machines from the leading global suppliers. Today this is a full-on research and development facility spreading across 150.000 square metres of territory which includes a climatic equipment research and development centre and a comprehensive suite of state-of-the-art laboratories.

The full-time staff of more than 200 engineers are continuously seeking to improve the VENTS products. The company utilises cutting-edge metal and polymer processing technology manufacturing 99 % of its products in-house.

We are the only company in the industry which develops and builds 85 % of its ventilation equipment components including electric motors, heat exchangers as well as control and automation equipment.



## Getting better every day

The world of today is nothing but stable or permanent. Each day the market comes up with new expectations with regards to ventilation equipment quality and performance. Therefore, VENTS places a strong emphasis on constant development and improvement.

To this end the company has adopted a policy which includes continuous upgrades to its process equipment fleet, implementing the latest in manufacturing technology, and holding regular training workshops for its staff. Not only does this help us keep abreast with the times – these efforts help us to exceed our customers' expectations.



## Uncompromising quality

VENTS maintains a stringent quality control system to make sure that its products always meet most demanding international standards as confirmed by numerous certificates issued by the world's largest and most reputable organisations for quality control. The VENTS production process is certified according to ISO 9001:2015 international

standard for quality management systems of organizations and enterprises. The company operates in accordance with all the applicable environmental standards and continuously implements new technology in order to ensure compliance with the latest environmental regulations.

## Energy efficiency and energy saving

Energy resources are finite and costly. This is why energy-saving is among the company's top priorities. We pay a special attention to using heat and electricity in the most efficient manner which helps us reduce the environmental footprint of the manufacturing process and develop

more competitive products. The outstanding energy efficiency and low power consumption of our ventilation equipment are achieved by using high-performance EC motors and heat exchangers.

## Human resources: a valuable asset



Besides maintaining technical leadership and developing new technology the company also values the people that it owes its success to.

Today VENTS employs more than 3.500 professionals involved in the entire life cycle of ventilation equipment creation – from concept to high-tech product. The company strives to create a comfortable working environment for its employees to maximise their performance and encourage their professional and personal development.

## Responsible corporate citizen



Being a responsible corporate citizen VENTS takes an active part in various academic and charity initiatives. The company has a long history of cooperation with a number of educational establishments extending its support to talented youth.

The company takes an active part in student competitions and workshops sharing its wealth of practical knowledge and providing access to state-of-the-art ventilation equipment. The company employees participate in a range of charitable events and sporting competitions on a regular basis.

## Following the customer's lead

*VENTS uses its extensive research and technical capabilities to develop bespoke ventilation products and solutions for its customers from around the world.*

*Our products have earned a reputation for reliability being used in polar regions and in the Sahara desert, in the jungle of South-Eastern Asia and in the Pamir mountains.*

*Wherever our customers are they can always depend on prompt delivery thanks to our worldwide network of strategically located logistics centres.*

*The company's newest arrivals are presented by its engineers at numerous international exhibitions every year.*

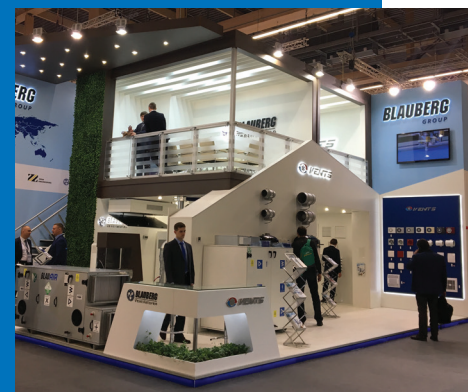

**Welcome to the world of modern ventilation by VENTS!**

# VENTILATION IN OUR LIFE



## ▶ What Is Ventilation?

Ventilation is a set of actions and techniques used to arrange air exchange and to provide a specific air medium condition in the premises and in working places. Ventilation maintains desirable indoor climatic parameters in compliance with set hygienic norms and technology requirements.

## ▶ What Is Ventilation Required For?

We are surrounded with air and breathe in and out 20 000 litres of air every day. How much healthy is the air we breath in? There is a range of aspects to determine air quality.

- ▶ **Oxygen and carbon dioxide concentration in the air.** Oxygen decrease and carbon dioxide cause stuffiness in the premises.
- ▶ **Concentration of harmful substances and dust in the air.** High concentration of dust, tobacco smoke and other substances in the air is harmful for health and can cause various lung and skin diseases.
- ▶ **Odours.** Bad smell causes discomfort and irritates.
- ▶ **Air humidity.** Too high or low humidity makes us feel uncomfortable and even may provoke acute conditions. Air humidity is important also for inner climate. For instance, doors, window frames, furniture may shrink because of too low humidity in winter and get swollen in humid environments, e.g. in swimming-pools, bathrooms.
- ▶ **Air temperature.** The comfortable indoor temperature is within 21-23 °C. Higher or lower temperatures influence physical and mental activity and health condition.
- ▶ **Air motion.** Increased air motion in the premises causes drafts and low air motion causes air blanketing. Any of these factors influence our well-being.

## ▶ Ventilation system arrangement

Properly arranged ventilation system is the only solution in this situation. It provides supply of filtered air in summer and supply of filtered and warmed up air in winter as well as extract stale air removal from the premises.

Any ventilation system must include synchronous fresh air supply and extract air exhaust thus ensuring the ideal air balance in the room. In case of poor or insufficient

air intake from outside the oxygen content decreases, humidity and dustiness level increase. If exhaust ventilation is not provided or it is not efficient, polluted air, smells, humidity and harmful substances are not removed.

One more important factor for properly arranged ventilation system is joint operation of supply and exhaust air vents. If indoor ventilation is provided by air exhaust only, e.g. by an extract bathroom fan, the only possible air supply source is the gaps in windows, doors and construction elements. This uncontrollable air supply results in dust ingress, smells and draughts.

Ventilation grilles in the bathroom doors, wall or window vents, open windows are the only natural supply air sources that may compensate for air extraction. However mechanical ventilation is the only solution to provide central air supply in the rooms.

## ▶ Calculation of the required air exchange.

### Ventilation design recommendations

#### Calculation of air exchange according to air exchange rate:

Ventilation air volume is determined for each premise separately considering concentration of harmful substances. Alternatively, ventilation air volume calculated be set according to the research results. If the nature and concentration of harmful substances is not possible to determine, air exchanged is calculated as following:

$$L = V \text{ prem.} * \text{Ach} \quad [\text{m}^3/\text{h}],$$

where **V prem.** – premise volume [m<sup>3</sup>];

**Ach** – minimum air exchange per hour, refer air exchange table.

### How to determine a premise volume?

Use a simple formula:

**length x width x height = volume of the premises in cubic meters**

$$A \times B \times H = V \text{ [m}^3\text{]}$$

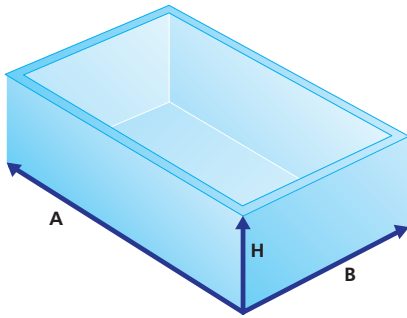

Example: a premise with 7 m length, 4 m width and 2.8 m height. To determine the air volume required for ventilation of this premises, calculate the room volume  $7 \times 4 \times 2.8 = 78.4 \text{ m}^3$ . After that determine the required efficiency of the fan using the following tables of recommended ventilation rate.

### Calculation of air exchange according to number of inhabitants:

$$L = L_1 * N_L \text{ [m}^3\text{/hour]},$$

where  $L_1$  – rated value for air volume per one person,  $\text{m}^3/\text{h}^*$ person;

$N_L$  – number of inhabitants in the premises

20-25  $\text{m}^3/\text{h}$  per one person at low physical activity

45  $\text{m}^3/\text{h}$  per one person at light physical activity

60  $\text{m}^3/\text{h}$  per one person at heavy physical activity

### Calculation of air exchange with vapor emission:

$$L = \frac{D}{(d_v - d_n) * \rho} \text{ [m}^3\text{/hour]}$$

$D$ : moisture, g/hour

$d_v$ : moisture content in the exhaust air, gram of water/kg of air

$d_n$ : moisture content in the intake air, gram of water/kg of air

$\rho$ : air density,  $\text{kg}/\text{m}^3$  (at  $20^\circ\text{C} = 1.205 \text{ kg}/\text{m}^3$ )

### Calculation of air exchange to remove excessive heat:

$$L = \frac{Q}{\rho * C_p * (t_v - t_n)} \text{ [m}^3\text{/hour]}$$

$Q$ : heat emission in the premises, kW

$t_v$ : exhaust air temperature,  $^\circ\text{C}$

$t_n$ : intake air temperature,  $^\circ\text{C}$

$\rho$ : air density [ $\text{kg}/\text{m}^3$ ] at  $20^\circ\text{C} = 1.205 \text{ kg}/\text{m}^3$

$C_p$ : heat capacity of air [ $\text{kJ}/(\text{kg}\cdot\text{K})$ ] at  $20^\circ\text{C}$ ;  $C_p = 1.005 \text{ kJ}/(\text{kg}\cdot\text{K})$

### Air ventilation rate:

Premise	Air exchange rate	
Domestic premises	Living room of apartments or hostel residential premises	3 $\text{m}^3/\text{h}$ for 1 $\text{m}^2$ in residential premises
	Kitchen in flat or hostel	6-8
	Bathroom	7-9
	Shower cabin	7-9
	WC	8-10
	Home laundry room	7
	Cloakroom	1.5
	Storeroom	1
	Garage	4-8
	Cellar	4-6
	Industrial premises and large premises	Theatre, cinema, confrence hall
Office		5-7
Bank		2-4
Restaurant		8-10
Bar, caf�, pub, billiard room		9-11
Professional kitchen		10-15
Supermarket		1.5-3
Chemist's		3
Garages and vehicle repair shops		6-8
Public WC		10-12 (or 100 $\text{m}^3$ per each WC pan)
Dance halls and disco clubs		8-10
Smoking rooms		10
Server rooms		5-10
Sport hall		80 $\text{m}^3$ or more for each sportsman and 20 $\text{m}^3$ or more for each viewer
Hair dresser's		
Up to 5 working places		2
More than 5 working places		3
Warehouses		1-2
Laundryroom		10-13
Swimming pool		10-20
Industrial painting shop	25-40	
Machine shop	3-5	
School classroom	3-8	

### Calculation of air exchange depending on maximum permissible concentration of aggressive substances in the air:

$$L = \frac{G_{\text{CO}_2}}{U_{\text{PDK}} - U_p} \text{ [m}^3\text{/hour]}$$

$G_{\text{CO}_2}$ :  $\text{CO}_2$  release amount [ $\text{l}/\text{hour}$ ]

$U_{\text{PDK}}$ :  $\text{CO}_2$  maximum permissible concentration,  $\text{l}/\text{m}^3$

$U_p$ : gas concentration in the intake air,  $\text{l}/\text{hour}$

## COUNTERFLOW HEAT RECOVERY UNITS IN METAL CASING

### Automation

▶ The **VUT 300 EH EC A21** units are equipped with integrated control system. The A21 controller allows integrating the unit into the **Smart Home system** or **BMS (Building Management Systems)**.

### Filter

▶ High degree of air purification is achieved due to G4-F7 incorporated panel type filters on metal frames. Filter size match the European Norms and Standards. Filter clogging control by means of integrated automation system as well as filter easy removal and cleaning ensure their quality and durability.

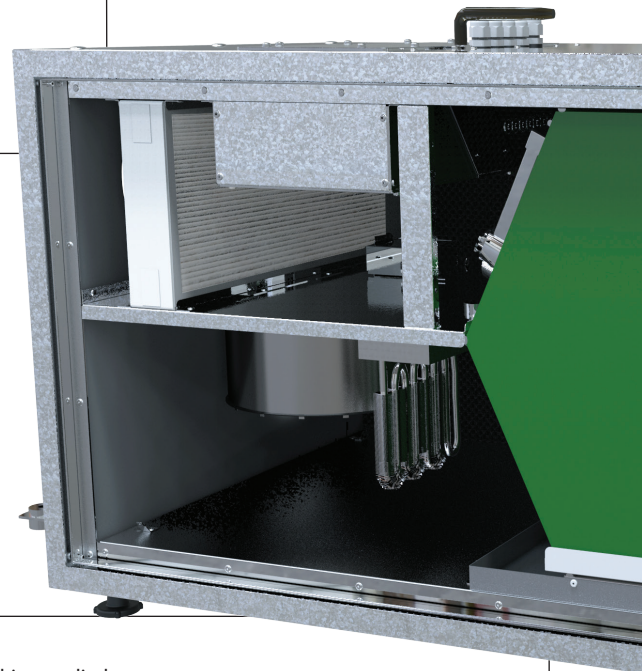
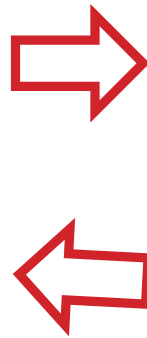

### Heater:

▶ Electric heater is designed for air handling unit operation at low outside temperature and is supplied as a standard.  
▶ Electric heater is made of heat-resisting stainless steel ribbed to increase the heat exchange surface area and equipped with two overheating protecting thermostats.

### Heat exchanger (recuperator)

▶ Plate heat exchanger with a great surface area and high efficiency made of polystyrene. The extract air transfers heat to the plates and the plates transfer heat to supply air flow. The heat exchange efficiency is up to 95 % which allows reducing heating costs. The supply and extract air flows do not get mixed which ensures no contamination, odours, microbes transfer. By-pass damper provides switching to no heat recovery mode if required.

Heat recovery



Control system



Effective insulation



**Photo:**  
**VUT 300 EH EC A21**

**Casing**

▶ The casing is made of two-layers aluminum-zinc compound internally filled with the mineral wool layer for heat and sound insulation. The internal sheet is made of aluminum-zinc steel plates with varnish coating to ensure long service life. The internal galvanized steel plate provides the surface hygienic purity of the unit and disables dirt accumulation on the panel. The side panels can be easily removed for inspection and service of all the unit elements.

**Fan with EC motor:**



- ▶ Air supply and exhaust is effected by means of two centrifugal single-inlet EC fans equipped with forward curved blades.
- ▶ EC motor is a synchronous brushless electronically commutated motor. EC motors have energy consumption by up to 50 % less as compared to standard motors of the same capacity. The operating costs for their maintenance are by 30 % less.
- ▶ Such fan design ensures minimum noise level combined with high capacity.

**Anti-vibration rubber mount:**

▶ Mounting the unit onto the rubber anti-vibration mounts makes its operation totally quiet and vibration-free and disables vibration transfer to buildings.

**Drain pan:**

▶ The unit is equipped with the drain pan of painted steel for condensate collection. Draining pipes for condensate drainage on the bottom are connected to the draining system.

Simple installation



Energy-saving EC motors

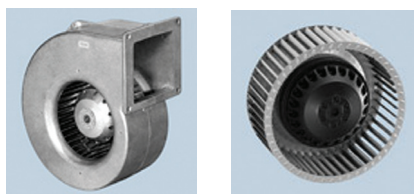

Easy maintenance

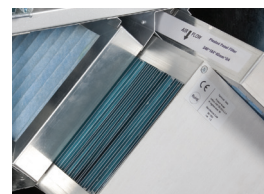

The issue of ventilation from the point of view of thermal energy saving (maintaining permanent temperature) is the most essential subject. The factors that influence the heat loss dynamics vary from wall thermal protection to heaters and heating system quality, density of wall panels joints and window joints as well as personal consumption habits.

In modern buildings ventilation demands up to 45 % of the total heat energy consumption. The reasons are as follows:

- a) One half of air volume is exchanged through the open window within 30-60 min. During this process the heat losses grow tremendously;
- b) Energy saving houses are equipped with all available facilities for sealing and thermal isolation of the buildings. Such houses are so well insulated that the heat loss through the walls makes only 30 to 40 % of the total amount.

Thus the heat losses caused by ventilation process remove 2/3 of the total heat. So we come to the point of providing air exchange with minimum heat losses. From 30 % to 70 % of heat loss is variously estimated for the traditional for residential houses exhaust ventilation. Controllable air exchange and heat recovery are the compulsory attributes in the modern construction that are ensured by means of air handling units. The forced ventilation allows recuperating up to 90 % of the exhaust air heat. Such effect is attained due to installation of the heat exchanger (recuperator).

The heat exchanger allows saving heat in winter period and contributes to better operation of air conditioners jointly with ventilation system in summer period. In addition the heat exchangers have heat- and soundinsulated casing that reduces the noise level produced by equipment in the room. As of today the ventilation systems based on heat exchangers are the most state-of-the-art and progressive solution for air exchange arranging in the premises.

Due to recuperation of the unit its owner can save good money for operation costs. Use of the ventilation units with heat recovery jointly with the air conditioning systems is not only the most effective way to arrange the required microclimate in the room but to cut costs as well. In winter the heat exchanger saves heat and in summer it saves cool.

### Structure and operating principle of the plate heat exchangers

The design of the plate heat exchangers is such as to exclude the transfer of contaminants, odours and microbes from the exhaust air flow to the supply air flow as both warm (exhaust) and cold (supply) air flows are divided by wall elements of heat exchanger plates made of aluminium or polystyrene. Thermal energy quantity that is transferred from the exhaust air to the supply air depends exclusively on the thermal conductivity of the applied materials and temperature difference between two flows. Concurrently the warm exhaust air is heated and the cold supply air is cooled. Though there is no moisture exchange between the extract and supply air streams, a part of latent wet extract air energy is used for heat recovery. In case of low outside

- ▶ low energy demand;
- ▶ low investment for thermal energy generation and its distribution;
- ▶ no removable parts which means durability and long service life at continuous operation;
- ▶ high-efficient heat recovery and little investment result in high self-repayment;
- ▶ environmental protection.

The plate heat exchanger of cross-flow or counter-flow type is the simplest one and contains no movable parts and electrical connections; it separates the air streams fully; maintenance-free and requires no additional energy consumption.

Utilization of units with heat recovery in ventilation systems results in shortening of payback period and improving its ecological characteristics in view of low energy demand, low investment for heat energy generation and its distribution, careful attitude to environment.

New series of compact air handling units with EC (electronically commutated) motors provide energy consumption reducing up to 50 % as compared to traditional asynchronous motors. Operating costs will be by 30 % in general reduced.

Fans with EC motors have the following advantages:

- ▶ efficient operation at any rotation speed of fan impeller (up to zero) and significant winding electrical resistance;
- ▶ low heat generation that enables reducing performance losses of refrigeration equipment and compensate for heat generation of fan motors in case of utilization of EC motor fans in conditioning systems;
- ▶ fan overall dimensions can be reduced in case of the design with external rotor and EC motor advantages. Consequently the disadvantages related to large-scale overall dimensions that are typical for fans with standard motors are minimized;
- ▶ the maximum motor speed does not depend upon frequency (operation both at 50 Hz and 60 Hz is possible);
- ▶ high efficiency at low speed;
- ▶ design with external rotor to make it compact.

temperature and high extract air temperature the exhaust air temperature can drop down to dew point. Thus condensate is generated and the latent evaporation heat is released. During condensate generation the temperature difference between the warm and cold air streams in the heat exchanger is higher as compared to the process with no condensate. Thus that means higher heat energy extraction and higher heat recovery efficiency.

For that reason free condensate drainage shall be provided.

Use of plate heat exchangers in ventilation system results in shorter payback period and better ecological characteristics ensuring the further advantages:



Plate cross-flow heat exchanger operating logic

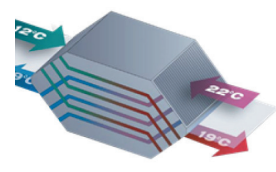

Plate counter-flow heat exchanger operating logic



Series  
**VENTS**  
**ENAVE-C 100/120 P**



Heat recovery air handling units in sound- and heat-insulated casings. Air flow up to **156 m<sup>3</sup>/h**. Heat recovery efficiency up to **94 %**

■ **Description**

The air handling units are the fully featured ventilation units with heat recovery for air filtration, fresh air supply and stale air extract. The units offer energy-efficient ventilation for small appartments.

■ **Casing**

The casing is made of expanded polypropylene (EPP) possessing high heat- and sound-insulating properties.

■ **Filter**

Two built-in Coarse 90% (G4) and ePM1 65% (F7) filters provide efficient air filtration.

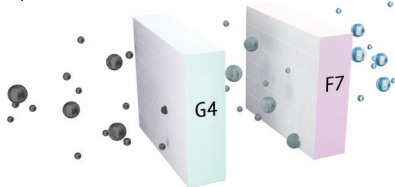

■ **Fans**

Efficient electronically commutated motors with external rotor and impeller with forward curved blades.

**Designation key**

TM	Model	Casing modification	Heat exchanger type	Nominal size	Modification	Casing type	Heater	Controller	Service side
VENTS	Enave	C – Compact	_ – heat recovery T – energy recovery	Air flow m <sup>3</sup> /h / 10	0 – standard	P – suspended	_ – w/o heater	A21, A14	L – left R – right

■ **Heat exchanger**

**Enave-C** units are equipped with a counter-flow polystyrene heat exchanger.

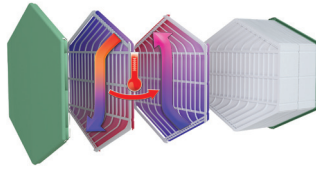

**Enave-CT** units are equipped with an enthalpy heat exchanger.

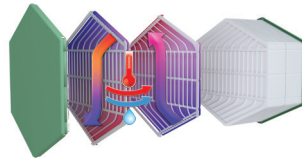

■ **Automation**

**Enave-C 100/120 P A21** units are equipped with automation system. The **A21** controller allows to integrate the unit into the **Smart Home system** or **BMS (Building Management System)**. To control the unit via Wi-Fi, download the **Vents Home** smartphone app. **Enave-C 100/120 P A14** units are equipped with an integrated control system and an **A14** wall-mounted control panel with LED indication.



Google play



Download on the App Store







■ **Freeze protection**

In the **Enave-C 100/120 P** units freeze protection is provided by the shutdown of the supply fan. Optional duct pre-heater is available for units with **A21** control system.

■ **Mounting**

The unit is designed for suspended ceiling mounting. The mounting position of the unit must provide service access for maintenance and repair.

■ **Control and automation**

Functions	A21	A14
Wired remote control pane	A22 (option) 	A14 
Control via a wired remote LCD control panel	A25 (option) 	-
Wireless remote control panel	A22 Wi-Fi (option) 	-
BMS	ModBus RTU (RS-485) ModBus TCP/IP (Wi-Fi, Ethernet)	-
Vents Cloud Server service	+	-
Control via Wi-Fi using a smartphone app	+	-
Frost protection	+	+
Bypass	-	-
Week-scheduled operation	+	-
Filter replacement indication	Filter timer	+
Alarm indication	+	+
Speed selection	+	+
Timer	+	-
RH% sensor	Option	Option
CO <sub>2</sub> sensor	Option	Option
VOC sensor	Option	Option
PM2.5 sensor	Option	Option
Boost mode	+	-
Fireplace mode	+	-
Preheater connection	+	-
Reheater connection	+	-
Fire alarm sensor connection	+	+
Minimum supply air temperature control	+	-

**Unit design**

**Enave-C 100/120 P L**

**Enave-C 100/120 P R**

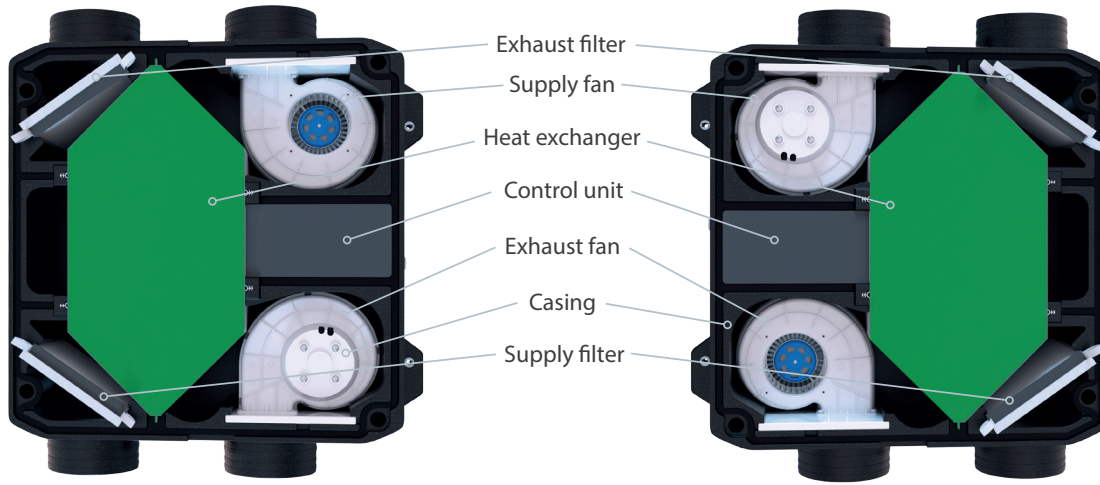

**Overall dimensions**

Model	Dimensions [mm]						
	ØD	Ød	H	W	L	W1	B
Enave-C 100/120 P	125	104	247	522	530	600	630

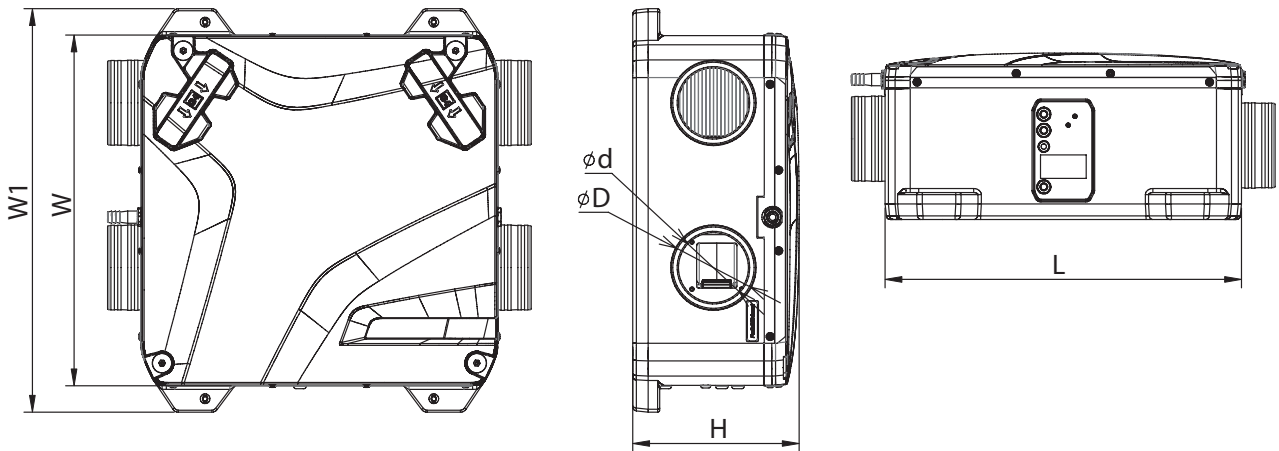

	Dimensions [mm]					
	L1	L2	L3	H1	H2	H3
External automation unit (only units with A21 automation)	324	313	93	180	330	196

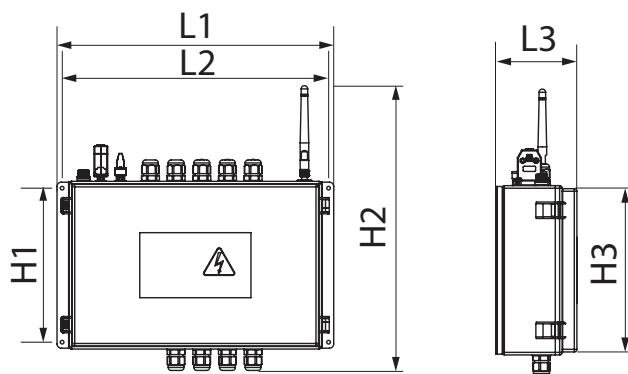

## COUNTERFLOW HEAT RECOVERY UNITS IN EPP CASING

### Technical data

	Enave-C 100 P	Enave-CT 100 P
Voltage [V/50-60 Hz]	1~ 230	
Max. unit power [W]	45	
Max. unit current [A]	0.34	
Max air flow [m <sup>3</sup> /h]	130	
Max. sound pressure level at 3 m distance (breakout) [dBA]	32	
Transported air temperature [°C]	- 23...+40	
Case material	EPP	
Insulation [mm]	25	
Extract filter	G4 / Coarse > 60%	
Supply filter	G4 / Coarse > 60% (option F7 / ePM1 60%)	
Connected air duct diameter [mm]	100 / 125	
Weight [kg]	8	
Heat recovery efficiency [%]	82-94	73-88
Heat exchanger type	Counter-flow	
Heat exchanger material	Polystyrene	Enthalpy membrane
SEC class	A+	A

Point	Air flow [m <sup>3</sup> h] (ls)		Total sound pressure level (break-out) at 3 m (1 m) distance [dBA]	
	Enave-C(T) 100 P		Enave-C(T) 100 P	
1	130 (36)		32 (42)	
2	91 (25)		25 (35)	
3	52 (14)		16 (26)	
4	52 (14)		31 (41)	
5	96 (27)		33 (42)	
6	68 (19)		25 (34)	

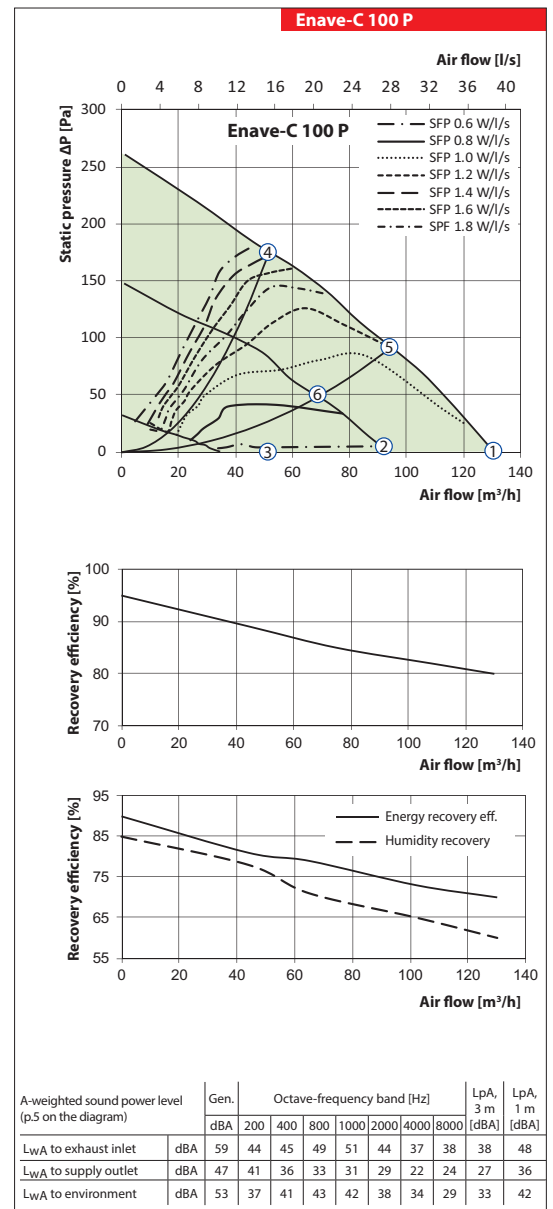

### Calculation of air temperature downstream of the heat exchanger:

$$t = t_{\text{outd}} + k_{\text{hr}} * (t_{\text{extr}} - t_{\text{outd}}) / 100,$$

where

$t_{\text{outd}}$  is outdoor air temperature [°C]

$t_{\text{extr}}$  is extract air temperature [°C]

$k_{\text{hr}}$  is heat exchanger efficiency (according to the diagram) [%]

**Technical data**

	Enave-C 120 P	Enave-CT 120 P
Voltage [V/50-60 Hz]	1~ 230	
Max. unit power [W]	59	
Max. unit current [A]	0.5	
Max air flow [m <sup>3</sup> /h]	156	
Max. sound pressure level at 3 m distance * (breakout) [dBA]	27	
Transported air temperature [°C]	- 23...+40	
Case material	EPP	
Insulation [mm]	25	
Extract filter	G4 / Coarse > 60%	
Supply filter	G4 / Coarse > 60% (option F7 / ePM1 60%)	
Connected air duct diameter [mm]	100/125	
Weight [kg]	8	
Heat recovery efficiency [%]	94	81
Heat exchanger type	Counter-flow	
Heat exchanger material	Polysterene	Enthalpy membrane
SEC class	A	A

\*Sound pressure level at 3 m distance is specified at point 4 [dBA] in average spherical free-field, for comparative use only.

Point	Total power of the unit, W		Total sound pressure level (breakout) at 3 m (1 m) distance [dBA]	
	Enave-CT 120 P		Enave-CT 120 P	
1	55		38 (48)	
2	55		36 (45)	
3	55		35 (44)	
4	21		27 (37)	
5	21		28 (37)	
6	21		29 (39)	
7	7		17 (27)	
8	7		17 (27)	
9	7		16 (26)	

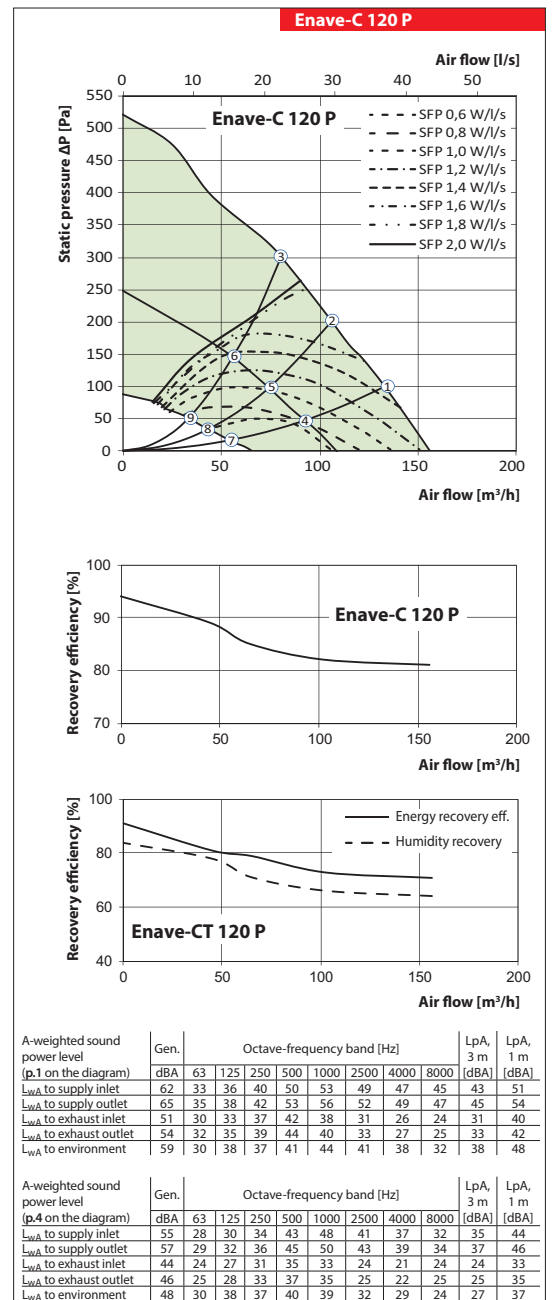

**Calculation of air temperature downstream of the heat exchanger:**

$$t = t_{outd} + k_{hr} * (t_{extr} - t_{outd}) / 100,$$

where







t<sub>outd</sub> is outdoor air temperature [°C]









t<sub>extr</sub> is extract air temperature [°C]

k<sub>hr</sub> is heat exchanger efficiency (according to the diagram) [%]

## COUNTERFLOW HEAT RECOVERY UNITS IN EPP CASING

### Accessories for air handling units

	Filter G4	Filter F7	Control panel	Control panel	Wi-Fi Control panel	Internal humidity sensor	Internal CO <sub>2</sub> sensor
							
Enave-C 100 P A21	SF 176x150x22 Coarse >60% G4	SF 176x150x22 ePM1 60% F7	A25	A22	A22 Wi-Fi	HV2	CO2-3
Enave-CT 100 P A21							
Enave-C 120 P A21							
Enave-CT 120 P A21	SF 176x150x22 Coarse >60% G4	SF 176x150x22 ePM1 60% F7	-	-	-	HV2	-
Enave-C 100 P A14							
Enave-CT 100 P A14							
Enave-C 120 P A14							
Enave-CT 120 P A14							

	External CO <sub>2</sub> sensor with indication	External CO <sub>2</sub> sensor	External humidity sensor	Electrical preheater	Electrical reheater	Syphon kit	Silencer	Air damper	Electric actuator
									
Enave-C 100 P A21	CO2-1	CO2-2	HR-S	NKP 125 A21 V.2	NKD 125 A21 V.2	SH-32	SR 125	KRV 125	TF 230
Enave-CT 100 P A21									
Enave-C 120 P A21									
Enave-CT 120 P A21	CO2-1	CO2-2	HR-S	-	-	SH-32	SR 125	KRV 125	TF 230
Enave-C 100 P A14									
Enave-CT 100 P A14									
Enave-C 120 P A14									
Enave-CT 120 P A14									



Series  
**VENTS Enave P**

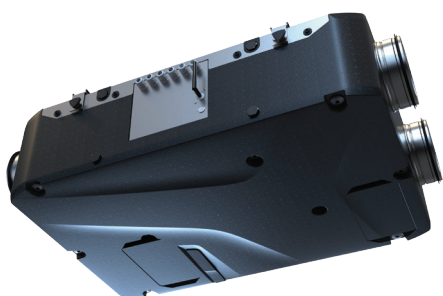

Heat recovery air handling units in sound- and heat-insulated casings.  
Air flow up to **310 m³/h**.  
Heat recovery efficiency up to **91 %**

**Description**

The air handling units are the fully featured ventilation units with heat recovery for air filtration, fresh air supply and stale air extraction. The units offer energy-efficient ventilation for small apartments.

**Casing**

The casing is made of expanded polypropylene (EPP) possessing high heat- and sound-insulating properties.

**Units Enave 181 / 241 P**

have flat service hatch design, suitable for decorative panel installation (delivered separately).

**Enave 180/240 P L** - left-handed unit.

**Enave 180/240 P R** - right-handed unit.

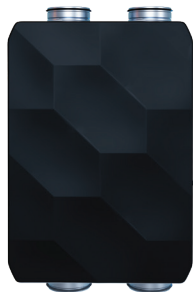

**Filter**

Two built-in **Coarse 90% (G4)** filters provide efficient air filtration. **ePM1 65% (F7)** supply filter can be installed as an option.

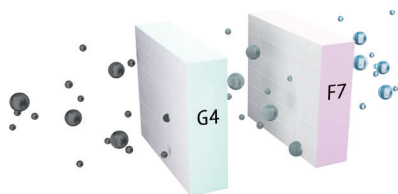

**Fans**

The units' fans are equipped with electronically-commutated motors.

**Heat exchanger**

**Enave** units are equipped with a counter-flow polystyrene heat exchanger.

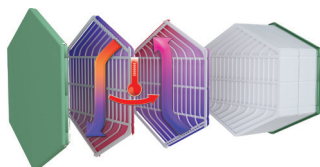

**Enave-T** units are equipped with an enthalpy heat exchanger.

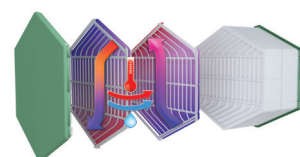

**Bypass**

The units are equipped with a bypass for summer cooling.

**Automation**

**Enave P A21** units are equipped with a built-in automation system. The **A21** controller allows to integrate the unit into the **Smart Home system** or **BMS (Building Management System)**. To control the unit via Wi-Fi, download the **Vents Home** smartphone app.

**Enave P A14** units have an integrated control system with a wall-mounted control panel with a LED indication.



**Frost protection**

For **Enave P** units, the frost protection is implemented by shutting down the supply fan. Optional duct pre-heater is available for units with **A21** control system.

**Mounting**

The unit is designed for suspended ceiling, wall and floor mounting. The mounting position of the unit must provide service access for maintenance and repair.

**Control and automation**

Functions	A14	A21
	A14	A22 (option)
Wired remote control panel		
Control via a wired remote LCD control panel	-	A25 (option) 
Wireless remote control panel	-	A22 Wi-Fi (option) 
BMS	-	ModBus RTU (RS-485) ModBus TCP/IP (Wi-Fi, Ethernet)
Vents Cloud Server service	-	+
Control via Wi-Fi using a smartphone app	-	+
Frost protection	+	+
Bypass	Manual	Auto, manual
Week-scheduled operation	-	+
Filter replacement indication	+	Filter timer
Alarm indication	+	+
Speed selection	+	+
Timer	-	+
RH% sensor	Option	Option
CO <sub>2</sub> sensor	Option	Option
VOC sensor	Option	Option
PM2.5 sensor	Option	Option
Boost mode	-	+
Fireplace mode	-	+
Preheater connection	-	+
Reheater connection	-	+
Fire alarm sensor connection	+	+
Minimum supply air temperature control	-	+

**Designation key**

TM	Model	Heat exchanger type	Nominal size	Modification	Casing type	Controller	Unit version
VENTS	Enave	-- heat recovery T - energy recovery	Airflow m³/h/10	0 - standart 1 - flat service hatch suitable for decorative panel installation	P - suspended	A21, A14	L: left-handed R: right-handed

**Unit design**

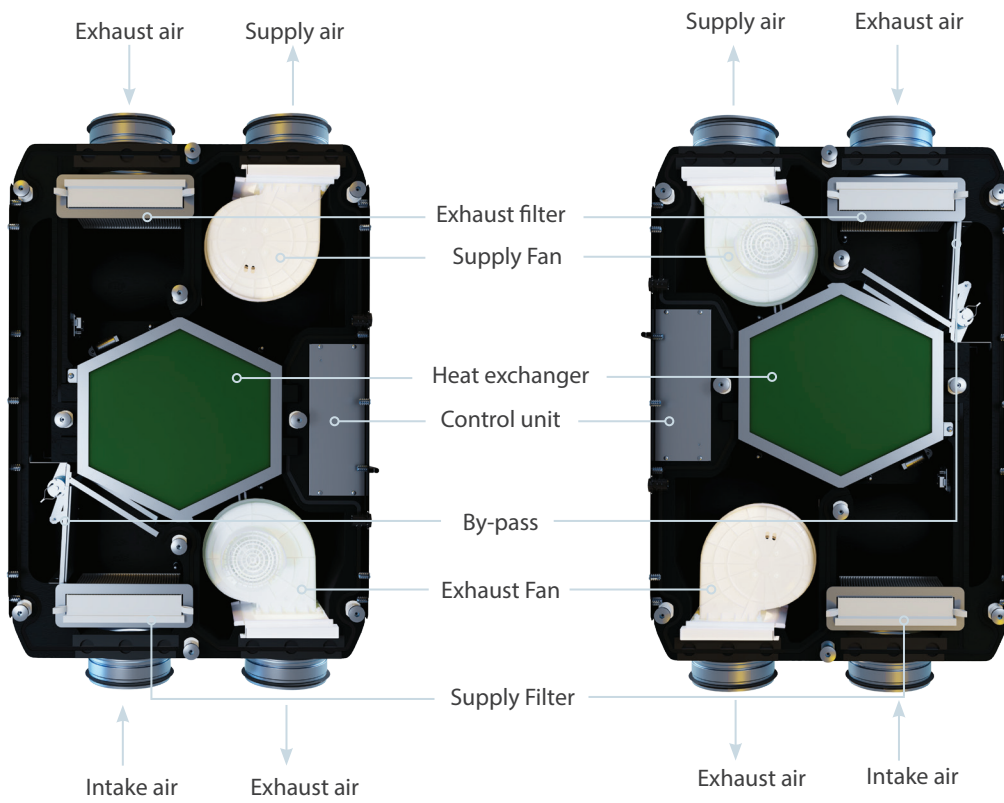

**Overall dimensions**

Model	Dimensions [mm]					
	H	W	L	ØD	W1	L1
Vents Enave P	272	640	930	160	300	617

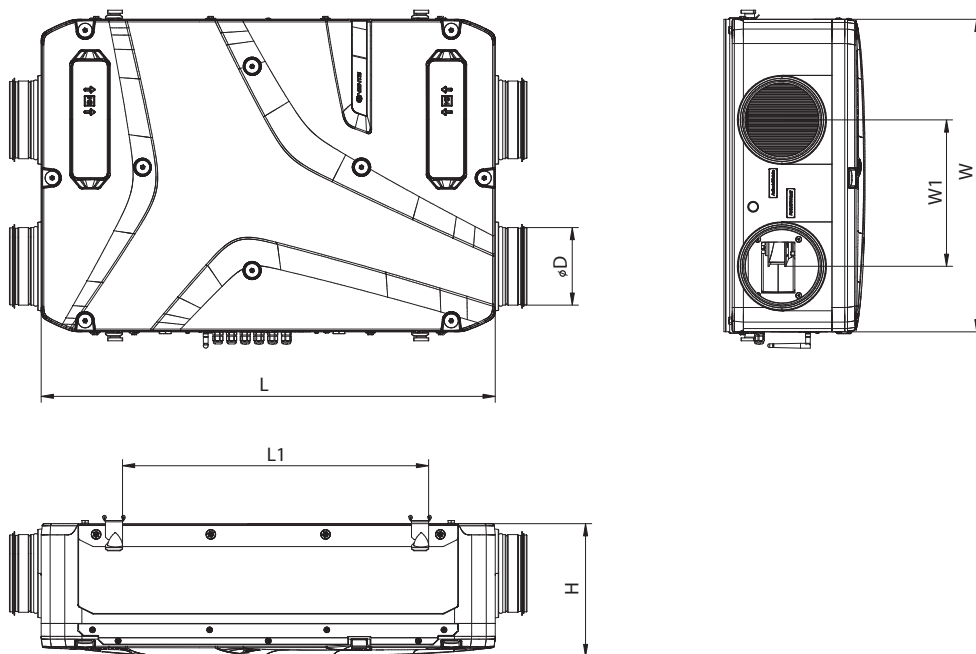

# COUNTERFLOW HEAT RECOVERY UNITS IN EPP CASING







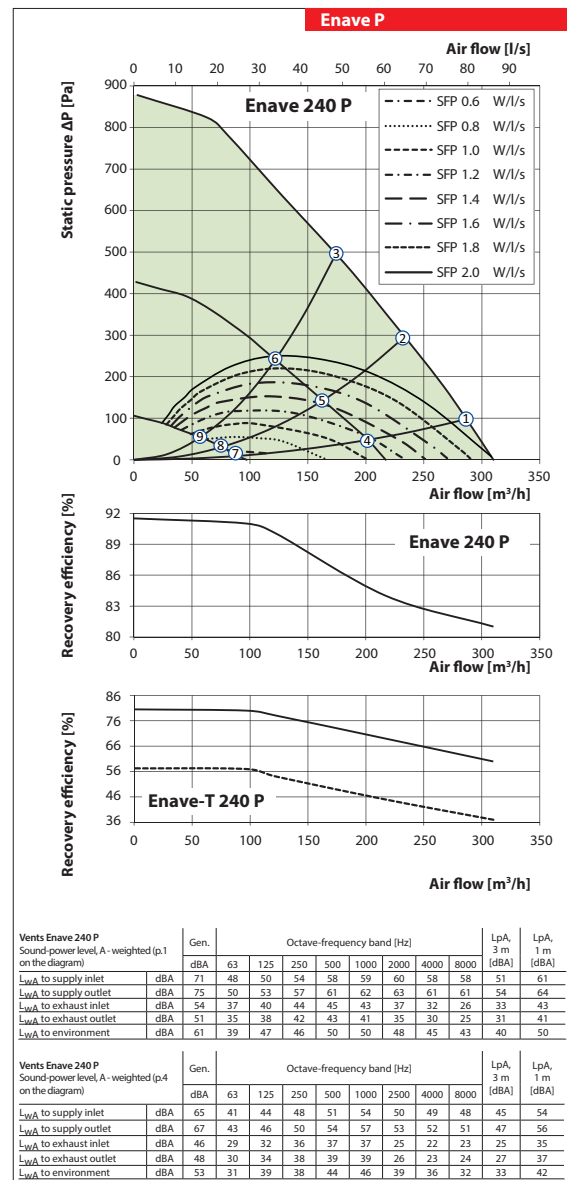
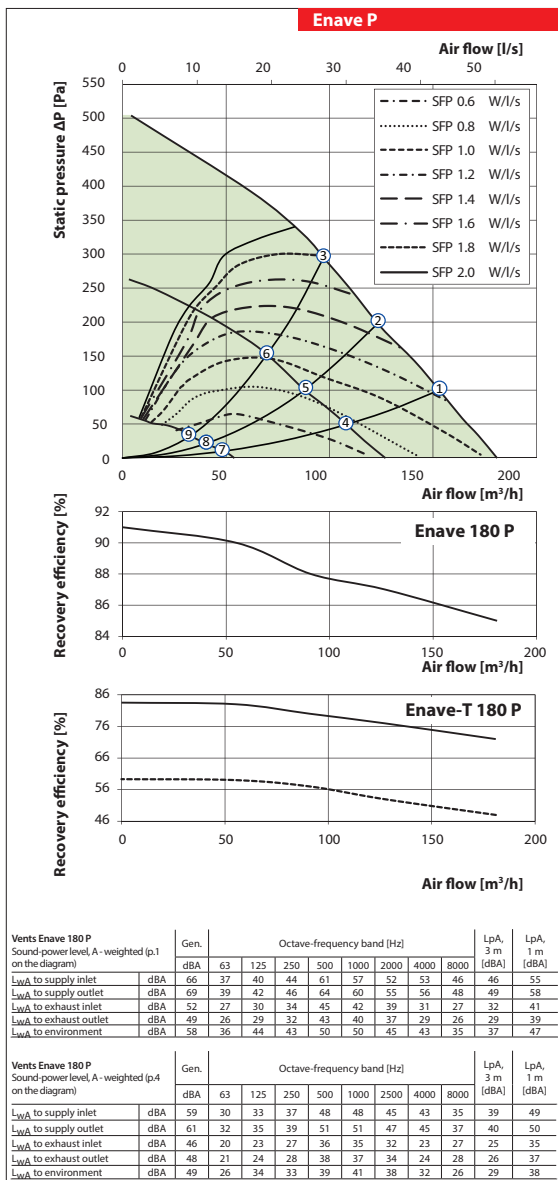

## Technical data

	Vents Enave 180 P	Vents Enave-T 180 P	Vents Enave 240 P	Vents Enave-T 240 P
Voltage [V / 50-60 Hz]	230	230	230	230
Max. unit power [W]	53	53	171	171
Max. unit current [A]	0.49	0.49	1.34	1.34
Max air flow [m <sup>3</sup> /h]	181	181	310	310
Sound pressure level at 3 m distance* [dBA]	29	29	33	33
Transported air temperature [°C]	-25...+40	-25...+40	-25...+40	-25...+40
Case material	EPP	EPP	EPP	EPP
Insulation	25 mm	25 mm	25 mm	25 mm
Extract filter	Coarse >60 %	Coarse >60 %	Coarse >60 %	Coarse >60 %
Supply filters	Coarse >60 % (option ePM1 60 %)	Coarse >60 % (option ePM1 60 %)	Coarse >60 % (option ePM1 60 %)	Coarse >60 % (option ePM1 60 %)
Connected air duct diameter [mm]	160	160	160	160
Weight [kg]	12	15	13	16
Heat recovery efficiency [%]	91	84	91	81
Heat exchanger type	Counterflow	Counterflow	Counterflow	Counterflow
Heat exchanger material	Polysterene	Enthalpy	Polysterene	Enthalpy
SEC class	A+	A	A	A

\*Sound pressure level [dBA] at 3 m distance is specified at point 4 in average spherical free-field, for comparative use only



**Accessories for air handling units**

	<b>Filter G4</b>	<b>Supply filter F7</b>	<b>Decorative panel</b>	<b>Control panel</b>	<b>Control panel</b>	<b>WiFi Control panel</b>	<b>Internal humidity sensor</b>	<b>Internal CO<sub>2</sub> sensor</b>
								
Enave 180 P A21	SF 205x200x48 Coarse 90% G4	SF 205x200x48 ePM1 60% F7	-	A25	A22	A22 Wi-Fi	HV2	CO2-3
Enave-T 180 P A21			-					
Enave 181 P A21			PD-Enave 181 P					
Enave-T 181 P A21			-					
Enave 240 P A21	SF 205x200x48 Coarse 90% G4	SF 205x200x48 ePM1 60% F7	-	-	-	-	HV2	-
Enave-T 240 P A21			-					
Enave 241 P A21			PD-Enave 181 P					
Enave-T 241 P A21			-					
Enave 180 P A14	SF 205x200x48 Coarse 90% G4	SF 205x200x48 ePM1 60% F7	-	-	-	-	HV2	-
Enave-T 180 P A14			-					
Enave 181 P A14			PD-Enave 181 P					
Enave-T 181 P A14			-					
Enave 240 P A14	SF 205x200x48 Coarse 90% G4	SF 205x200x48 ePM1 60% F7	-	-	-	-	HV2	-
Enave-T 240 P A14			-					
Enave 241 P A14			PD-Enave 181 P					
Enave-T 241 P A14			-					

	<b>External CO<sub>2</sub> sensor with indication</b>	<b>External CO<sub>2</sub> sensor</b>	<b>External humidity sensor</b>	<b>Electrical preheater</b>	<b>Electrical reheater</b>	<b>Syphon kit</b>	<b>Silencer</b>	<b>Air damper</b>	<b>Electric actuator</b>
									
Enave 180 P A21	CO2-1	CO2-2	HR-S	NKP 160 A21 V.2	NKD 160 A21 V.2	-	-	-	-
Enave-T 180 P A21									
Enave 181 P A21									
Enave-T 181 P A21									
Enave 240 P A21	CO2-1	CO2-2	HR-S	-	-	SH-32	SR 160	KRV 160	TF 230
Enave-T 240 P A21									
Enave 241 P A21									
Enave-T 241 P A21									
Enave 180 P A14	CO2-1	CO2-2	HR-S	-	-	-	-	-	-
Enave-T 180 P A14									
Enave 181 P A14									
Enave-T 181 P A14									
Enave 240 P A14	CO2-1	CO2-2	HR-S	-	-	-	-	-	-
Enave-T 240 P A14									
Enave 241 P A14									
Enave-T 241 P A14									

Series  
**VENTS Enave-C P**



Heat recovery air handling units in sound- and heat-insulated casings. Air flow up to **279 m³/h**. Heat recovery efficiency up to **89 %**

**Description**

The air handling units are the fully featured ventilation units with heat recovery for air filtration, fresh air supply and stale air extract. The units offer energy-efficient ventilation for small appartments.

**Casing**

The casing is made of expanded polypropylene (EPP) that has high heat- and sound-insulating properties. **Enave-C P** units have adjustable oriental connection of the flanges to provide more flexible installation solutions.

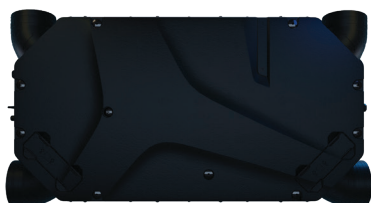

**Enave-C ... L** – left-handed version.

**Enave-C ... R** – right-handed version.

**Filter**

Two built-in **Coarse 90% (G4)** filters provide efficient air filtration. **ePM1 65% (F7)** supply filter can be installed as an option.

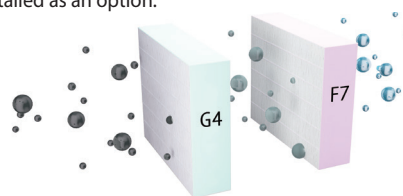

**Fans**

Units' fans are equipped with electronically-commutated motors.

**Enave-C(T) 230 P A21 CF** units are available with **Constant flow** function - the fans automatically maintain a constant air volume regardless of pressure changes in the duct system. Stable airflow is ensured up to 300 a external static pressure.

**Heat Exchanger**

**Enave-C** units are equipped with a counter-flow polystyrene heat exchanger.

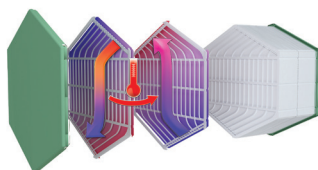

**Enave-CT** units are equipped with an enthalpy heat exchanger.

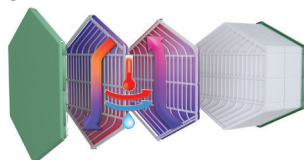

**Bypass**

Units are equipped with a bypass for summer cooling.

**Automation**

**Enave-C P A21** units are equipped with a built-in automation system. The **A21** controller allows to integrate the unit into the **Smart Home system** or **BMS (Building Management System)**. To control the unit via Wi-Fi, download the **Vents Home** smartphone app.

**Enave-C P A14** units have an integrated control system with a wall-mounted control panel equipped with LED indication.



Google play



Download on the App Store



**Frost protection**

For **Enave-C P** units frost protection is realized by shutting down the supply fan. Optional duct preheater is available for units with A21 control system.

**Mounting**

The unit is designed for suspended ceiling mounting. The mounting position of the unit must provide service access for maintenance and repair.

**Control and automation**

Functions	A21	A14
Wired remote control pane	A22 (option)	A14
Control via a wired remote LCD control panel	A25 (option)	-
Wireless remote control panel	A22 Wi-Fi (option)	-
BMS	ModBus RTU (RS-485) ModBus TCP/IP (Wi-Fi, Ethernet)	-
Vents Cloud Server service	+	-
Control via Wi-Fi using a smartphone app	+	-
Frost protection	+	+
Bypass	Auto, manual	Manual
Week-scheduled operation	+	-
Filter replacement indication	Filter timer	+
Alarm indication	+	+
Speed selection	+	+
Timer	+	-
RH% sensor	Option	Option
CO2 sensor	Option	Option
VOC sensor	Option	Option
PM2.5 sensor	Option	Option
Boost mode	+	-
Fireplace mode	+	-
Preheater connection	+	-
Reheater connection	+	-
Fire alarm sensor connection	+	+
Minimum supply air temperature control	+	-

**Designation key**

Model	Casng modification	Heat exchanger type	Nominal size	Modification	Casing type	Controller	Unit version	Airflow control
Enave	_ - Standard C - compact	_ - heat recovery T - energy recovery	Airflow m³/h/10	0 - standard	P - suspended	A21, A14	<b>L:</b> left-handed <b>R:</b> right-handed	_ - standard CF - constant flow

**Unit design**

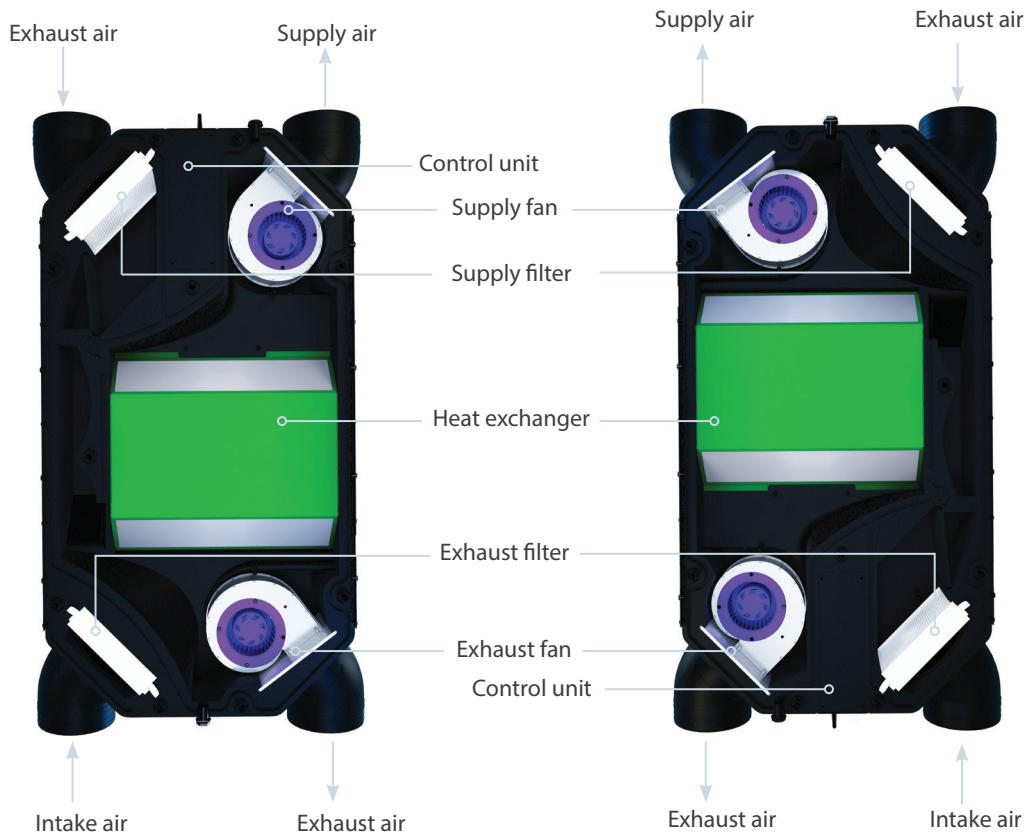

**Overall dimensions**

Model	Dimensions [mm]								
	H	W	L	W1	W2	W3	L1	ØD	ØD1
Enave-CP	242	683	1160	642	610	521	685	160	125

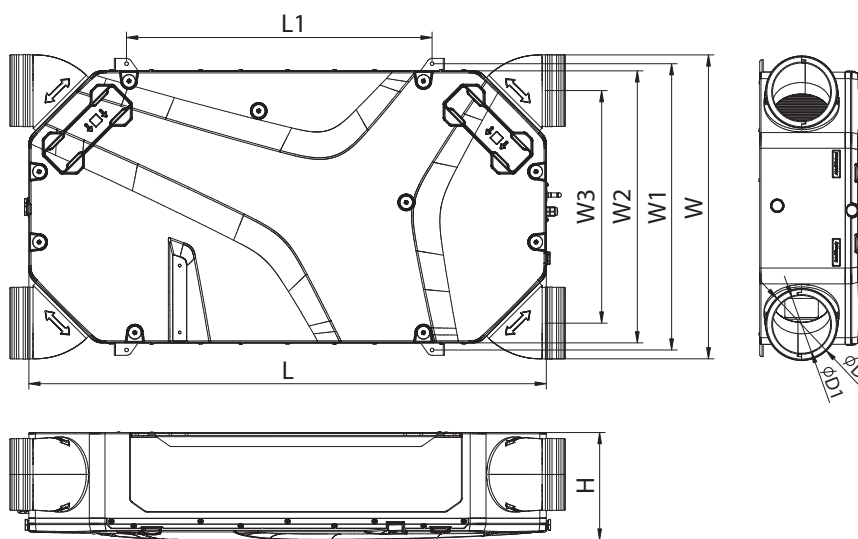

# COUNTERFLOW HEAT RECOVERY UNITS IN EPP CASING

## Technical data

	Enave-C 150 P	Enave-CT 150 P	Enave-C 200 P	Enave-CT 200 P
Voltage [V / 50-60 Hz]	230			
Max. unit power [W]	72			111
Max. unit current [A]	0.63			0.9
Max air flow [m <sup>3</sup> /h]	229			279
Sound pressure level at 3 m distance [dBA]	27	27	33	33
Transported air temperature [°C]	-25...+40			
Case material	EPP			
Insulation [mm]	25			
Extract filter	G4 / Coarse > 60%			
Supply filters	G4 / Coarse > 60% (option F7 / ePM1 60%)			
Connected air duct diameter [mm]	125 / 160			
Weight [kg]	18	19.5	18	19.5
Heat recovery efficiency [%]	89	85	89	85
Heat exchanger type	Counterflow			
Heat exchanger material	Polysterene	Enthalpy membrane	Polysterene	Enthalpy membrane
SEC class	A+	A	A+	A

\*Sound pressure level [dBA] at 3 m distance is specified at point 4 in average spherical free-field, for comparative use only.

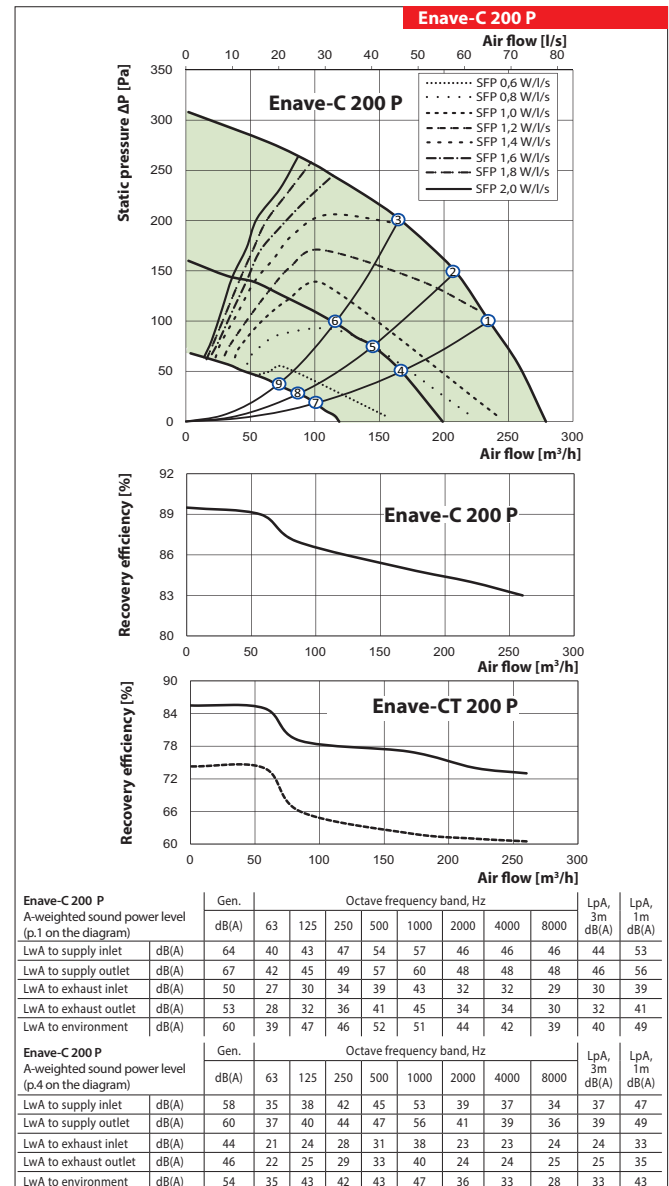
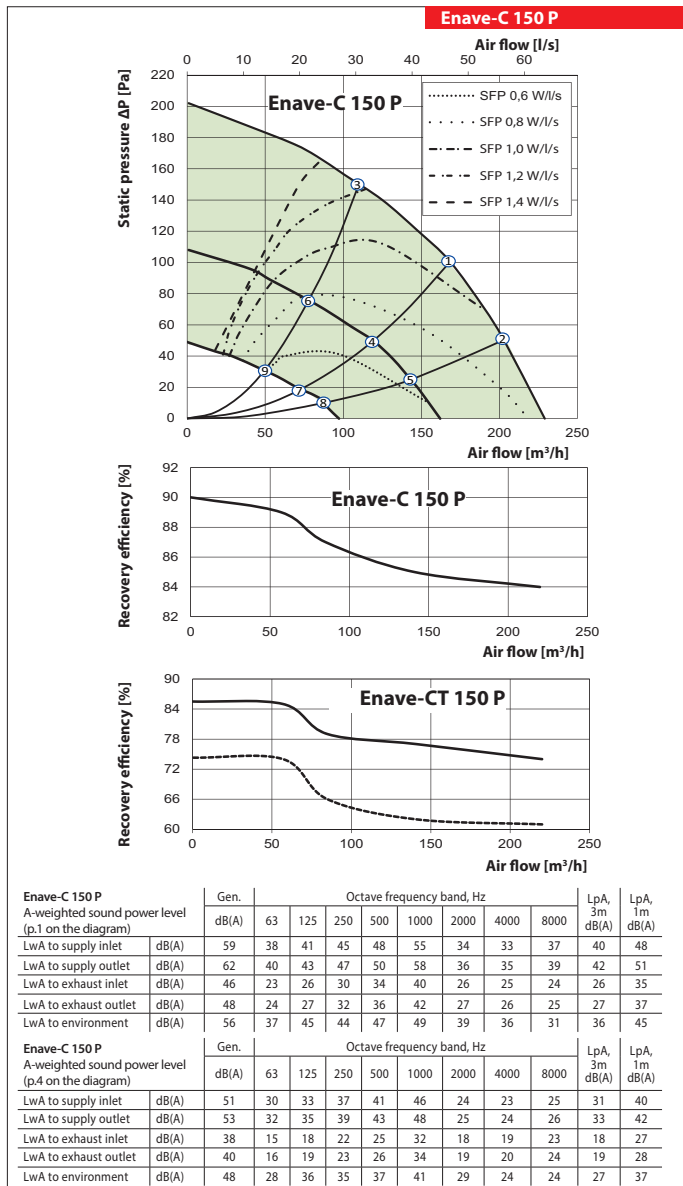

**Technical data**





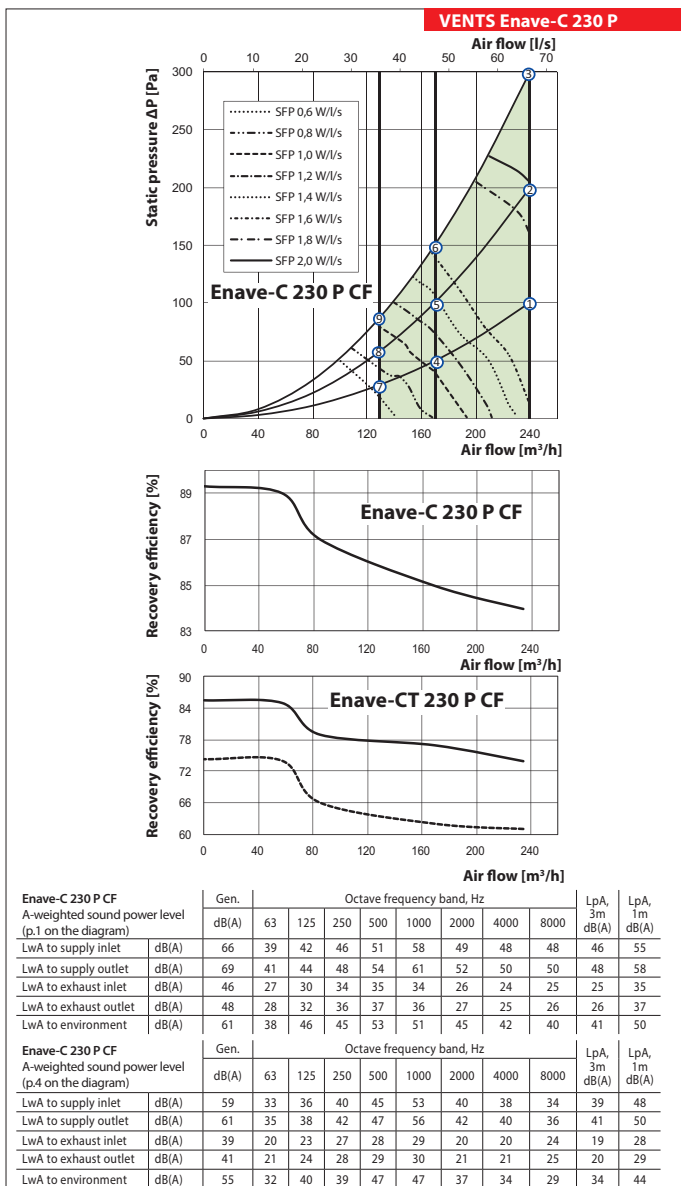

	Enave-C 230 P CF	Enave-CT 230 P CF
Voltage [V / 50-60 Hz]	230	
Max. unit power [W]	180	
Max. unit current [A]	1.4	
Max air flow [m <sup>3</sup> /h]	240	
Sound pressure level at 3 m distance* [dBA]	34	
Transported air temperature [°C]	- 25...+40	
Case material	EPP	
Insulation	25	
Extract filter	Coarse >60 %	
Supply filters	"Coarse >60 % (option ePM1 60 %)"	
Connected air duct diameter [mm]	125 / 160	
Weight [kg]	18	19,5
Heat recovery efficiency [%]	89	85
Heat exchanger type	Counterflow	
Heat exchanger material	Polysterene	Enthalpy membrane
SEC class	A	A

\* Sound pressure level [dBA] at 3 m distance is specified at point 4 in average spherical free-field, for comparative use only.



## COUNTERFLOW HEAT RECOVERY UNITS IN EPP CASING

### Accessories for air handling units

	Filter G4	Filter F7	Control panel	Control panel	Wi-Fi Control panel	Internal humidity sensor	Internal CO <sub>2</sub> sensor
							
Enave-C 150 P A21	SF 200x165x48 Coarse 90% G4	SF 200x165x48 ePM1 65% F7	A25	A22	A22 Wi-Fi	HV2	CO2-3
Enave-CT 150 P A21							
Enave-C 200 P A21							
Enave-CT 200 P A21							
Enave-C 230 P A21 CF							
Enave-CT 230 P A21 CF							
Enave-C 150 P A14	SF 200x165x48 Coarse 90% G4	SF 200x165x48 ePM1 65% F7	-	-	-	HV2	-
Enave-CT 150 P A14							
Enave-C 200 P A14							
Enave-CT 200 P A14							

	External CO <sub>2</sub> sensor with indication	External CO <sub>2</sub> sensor	External humidity sensor	Electrical preheater	Electrical reheater	Syphon kit	Silencer	Air damper	Electric actuator
									
Enave-C 150 P A21	CO2-1	CO2-2	HR-S	NKP 160 A21 V.2	NKD 160 A21 V.2	SH-32	SR 160	KRV 160	TF 230
Enave-CT 150 P A21									
Enave-C 200 P A21									
Enave-CT 200 P A21									
Enave-C 230 P A21 CF									
Enave-CT 230 P A21 CF									
Enave-C 150 P A14	CO2-1	CO2-2	HR-S	-	-	SH-32	SR 160	KRV 160	TF 230
Enave-CT 150 P A14									
Enave-C 200 P A14									
Enave-CT 200 P A14									



Series  
**VENTS Enave V**



Heat recovery air handling units in sound- and heat-insulated casings. Air flow up to **720 m³/h**. Heat recovery efficiency up to **91 %**

**Description**

The air handling units are the fully featured ventilation units with heat recovery for air filtration, fresh air supply and stale air extract. The units offer energy-efficient ventilation for small apartments.

**Casing**

The casing is made of expanded polypropylene (EPP) possessing high heat- and sound-insulating properties.

**Enave L** – left-handed version.

**Enave R** – right-handed version.

**Units Enave 351 / 381 / 401 V**

have flat service hatch design, suitable for decorative panel installation (delivered separately).



**Filter**

Two built-in **Coarse 90% (G4)** filters provide efficient air filtration. **ePM1 65% (F7)** supply filter can be installed as an option.

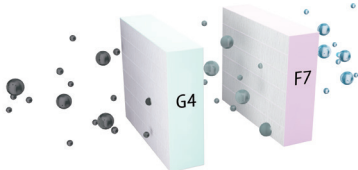

**Fans**

Units' fans are equipped with electronically commutated motors.

**Enave(-T) A21 CF** units are available with Constant flow function - the fans automatically maintain a constant air volume

**Heat Exchanger**

**Enave** units are equipped with a counter-flow polystyrene heat exchanger.

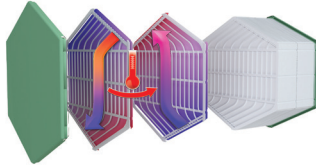

**Enave-T** units are equipped with an enthalpy heat exchanger.

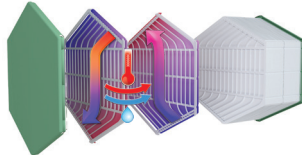

**Bypass**

Units are equipped with a bypass for summer cooling.

**Automation**

**Enave V A21** units are equipped with a built-in automation system. The **A21** controller allows to integrate the unit into the **Smart Home system** or **BMS (Building Management System)**. To control the unit via Wi-Fi, download the **Vents Home** smartphone app.

**Enave V A14** units have an integrated control system with a wall-mounted control panel equipped with LED indication.



Google play



Download on the App Store







**Frost protection**

For **Enave V** units the frost protection is realized by shutting down the supply fan. Optional duct pre-heater is available for units with A21 control system.

**Mounting**

The unit is designed for wall and floor mounting. The mounting position of the unit must provide service access for maintenance and repair.

**Control and automation**

Functions	A21	A14
Wired remote control pane	A22 (option) 	A14 
Control via a wired remote LCD control panel	A25 (option) 	-
Wireless remote control panel	A22 Wi-Fi (option) 	-
BMS	ModBus RTU (RS-485) ModBus TCP/IP (Wi-Fi, Ethernet)	-
Vents Cloud Server service	+	-
Control via Wi-Fi using a smartphone app	+	-
Frost protection	+	+
Bypass	Auto, manual	Manual
Week-scheduled operation	+	-
Filter replacement indication	Filter timer	+
Alarm indication	+	+
Speed selection	+	+
Timer	+	-
RH% sensor	Option	Option
CO <sub>2</sub> sensor	Option	Option
VOC sensor	Option	Option
PM2.5 sensor	Option	Option
Boost mode	+	-
Fireplace mode	+	-
Reheater connection	+	-
Fire alarm sensor connection	+	+
Minimum supply air temperature control	+	-

**Designation key**

Model	Heat exchanger type	Nominal size	Modification	Casing type	Heater	Control system	Version	Airflow control
Enave	- – heat recovery T – energy recovery	Air flow m³/h / 10	0 – standard	V - vertical	- – w/o heater E – integrated pre-heater	A21, A14	L – left R – right	- – standard CF - constant flow

**Unit design**

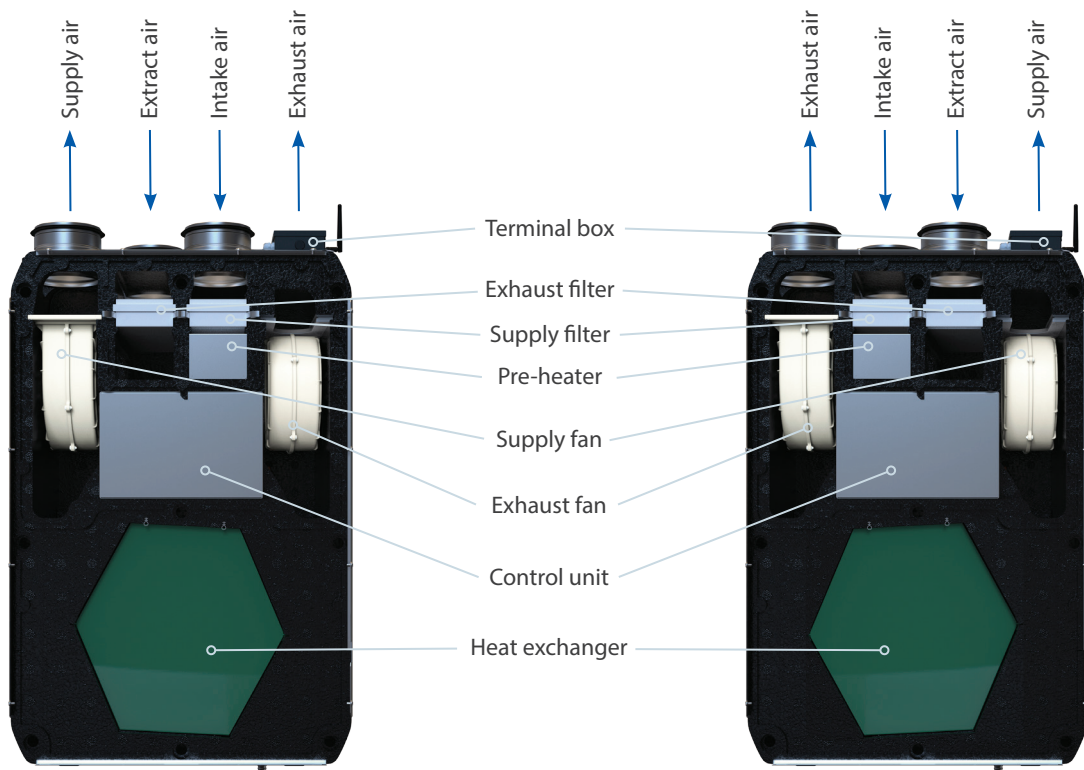

**Enave 210 / 270 V L, 240 V CF L**

**Enave 210 / 270 V R, 240 V CF R**

**Overall dimensions**

Model	Dimensions [mm]						
	H	W	L	H1	W1	L1	ØD
Enave 210/270 V, 240 V CF	900	598	452	958	273	190	125

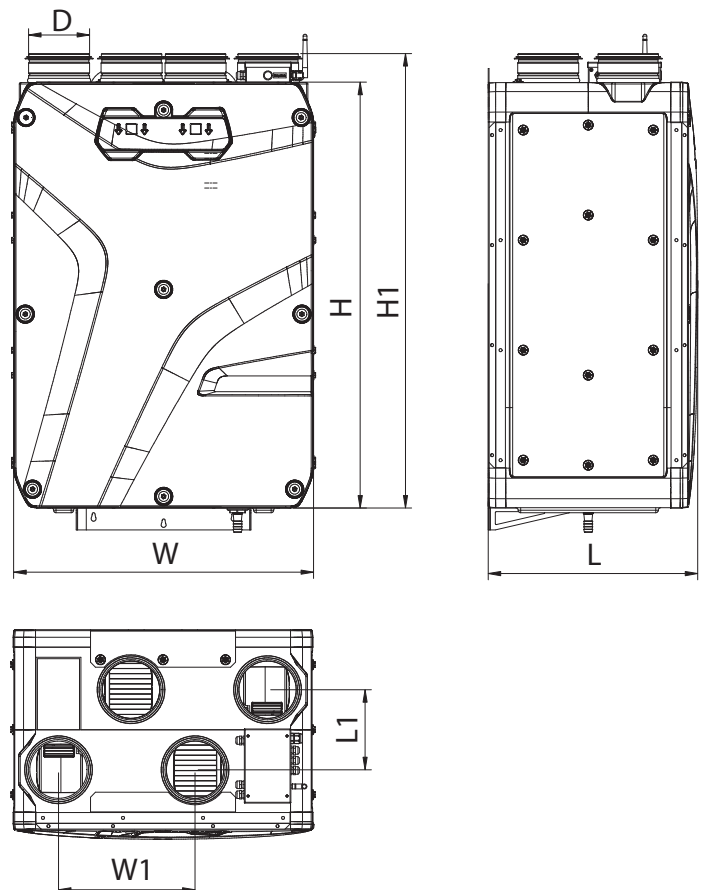

Unit design

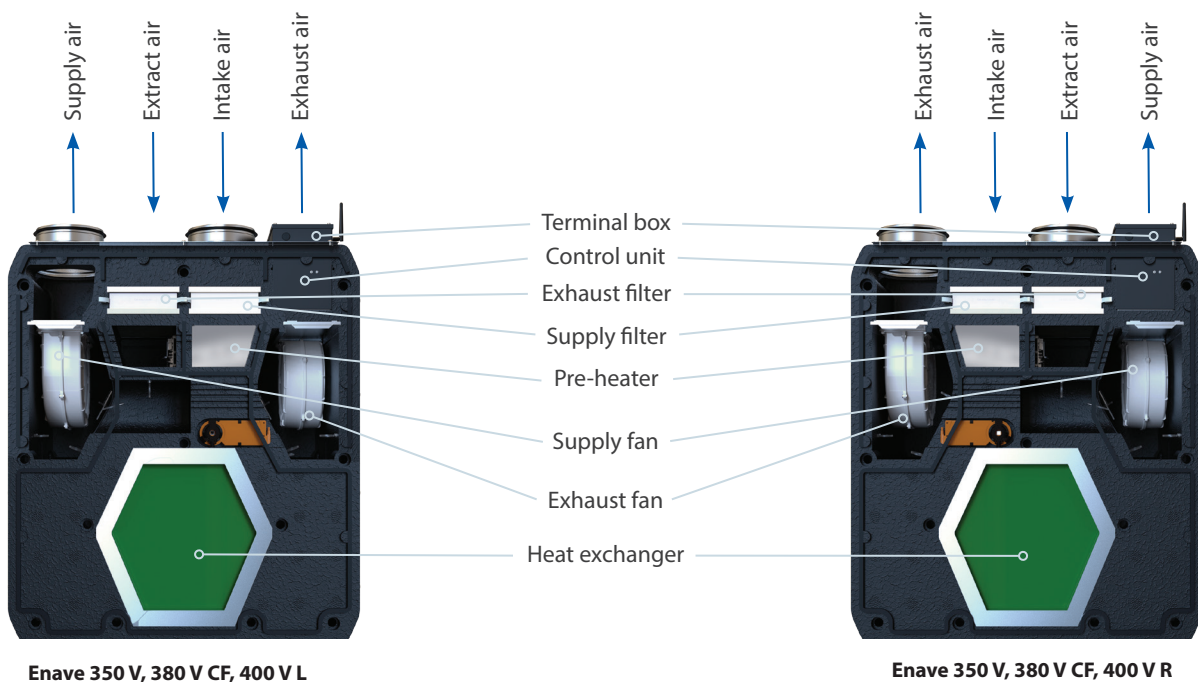

Overall dimensions

Model	Dimensions [mm]						
	H	W	L	H1	W1	L1	ØD
Enave 350 V, 380 V CF, 400 V	880	770	616	939	355	230	160

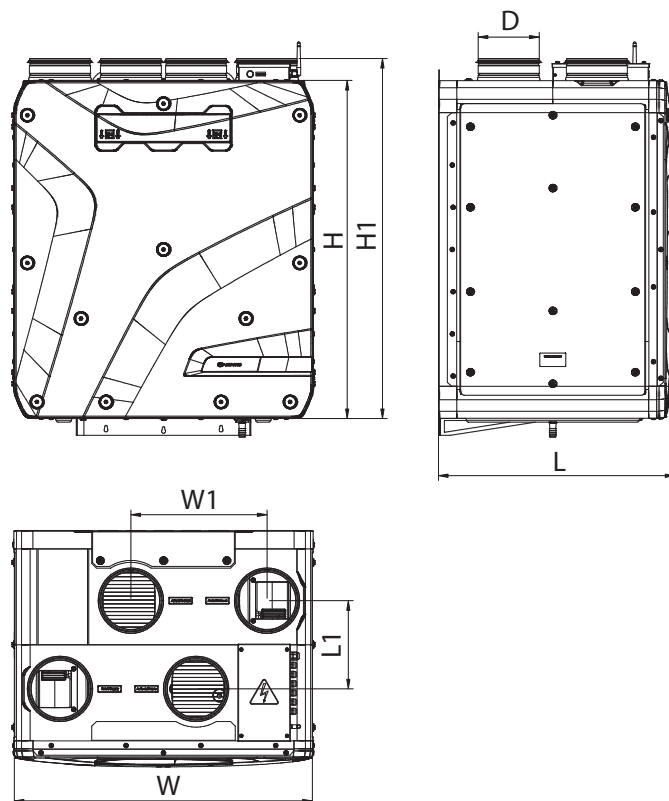

**Unit design**

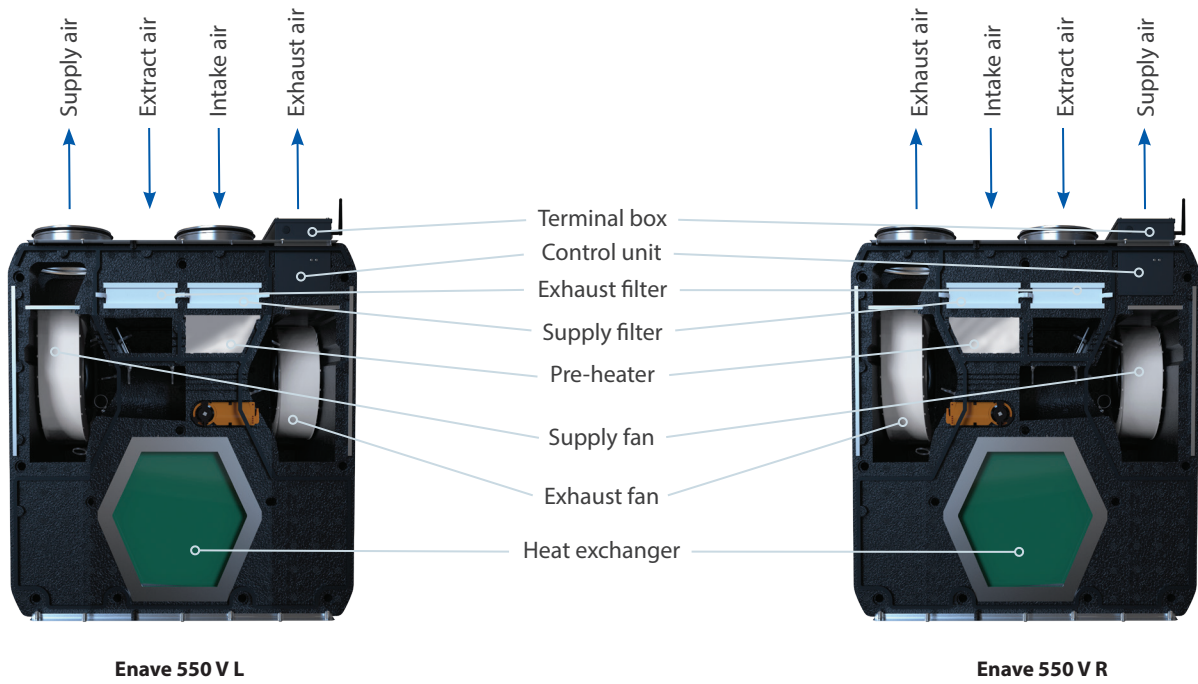

**Enave 550 V L**

**Enave 550 V R**

**Overall dimensions**

Model	Dimensions [mm]						
	H	W	L	H1	W1	L1	ØD
Enave 550 V	885	830	711	943	365	250	200

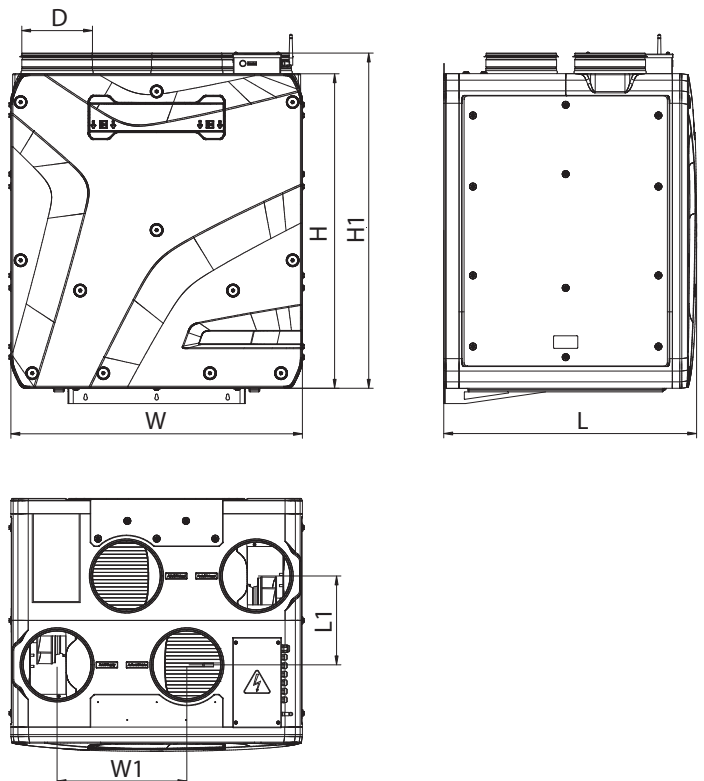

# COUNTERFLOW HEAT RECOVERY UNITS IN EPP CASING

## Technical data

	Enave 210 V	Enave-T 210 V	Enave 210 VE	Enave-T 210 VE	Enave 270 V	Enave-T 270 V	Enave 270 VE	Enave-T 270 VE
Voltage [V / 50-60 Hz]	230							
Max. unit power without electric heater [W]	125			182			182	
Integrated electric heater power [W]	-	-	800	800	-	-	1400	1400
Max. unit power [W]	125	125	925	925	182	182	1582	1582
Max. unit current without electric heater [A]	1.0			1.4			1.4	
Integrated electric heater current [A]	-	-	3.55	3.55	-	-	6.21	6.21
Max. unit current [A]	1.0	1.0	4.55	4.55	1.4	1.4	7.61	7.61
Max air flow [m³/h]	277			331			331	
Sound pressure level at 3 m distance [dBA]	31			34			34	
Transported air temperature [°C]	- 25...+40							
Insulation [mm]	25							
Extract filter	G4 / Coarse > 60%							
Supply filters	G4 / Coarse > 60% (option F7 / ePM1 60%)							
Connected air duct diameter [mm]	125							
Weight [kg]	20	22	20	22	22	24	22	24
Heat recovery efficiency [%]	89	83	89	83	89	83	89	83
Heat exchanger type	Counter-flow							
Heat exchanger material	Polysterene	Enthalpy membrane	Polysterene	Enthalpy membrane	Polysterene	Enthalpy membrane	Polysterene	Enthalpy membrane
SEC class	A+	A	A+	A	A	A	A	A

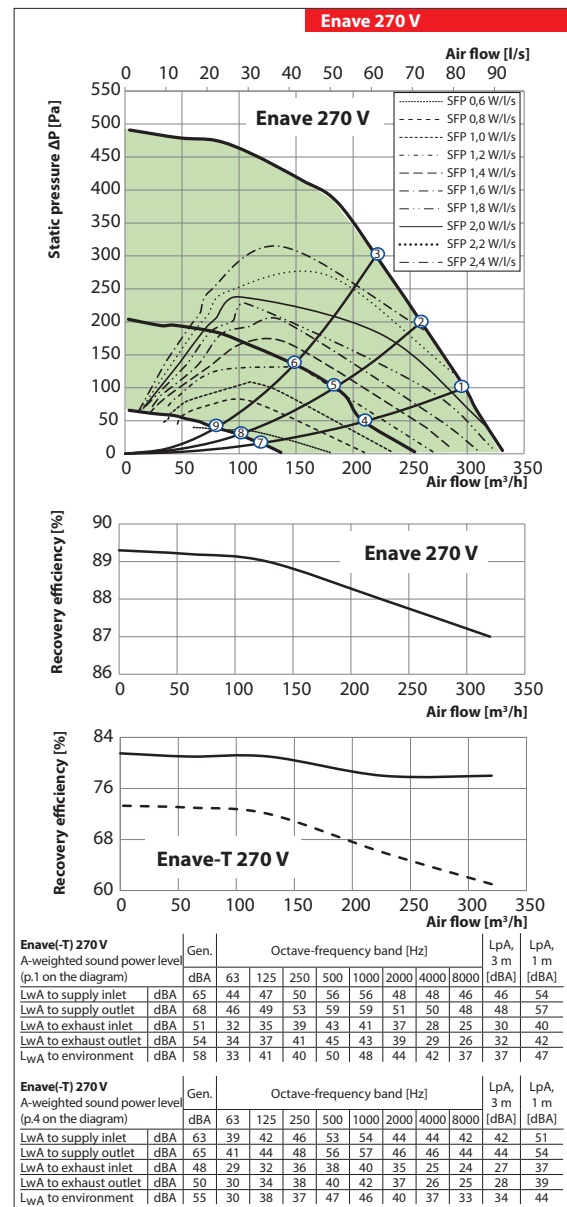
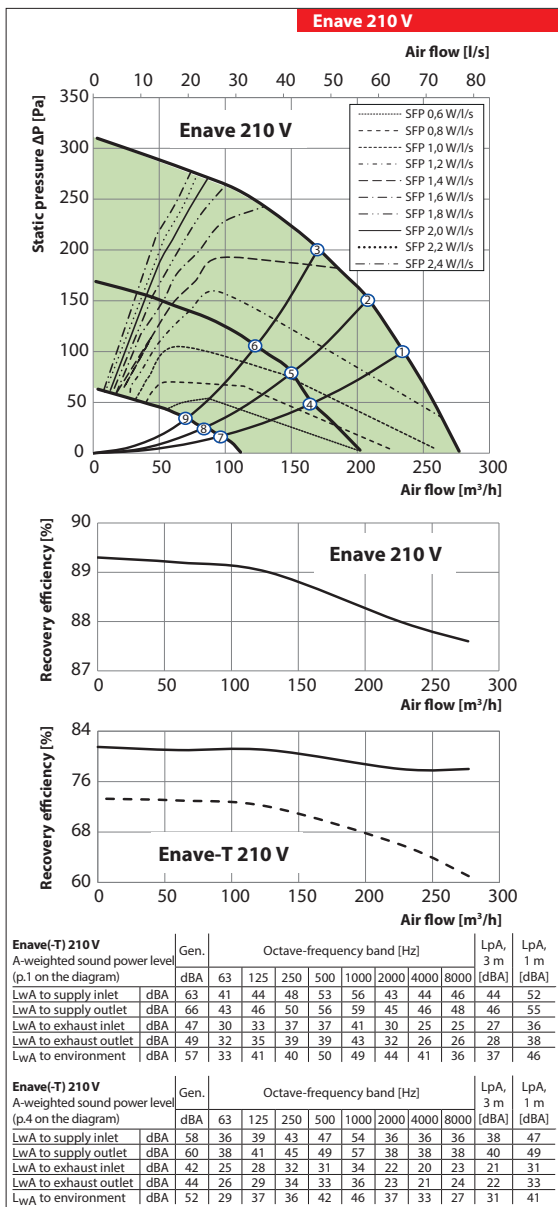

**Technical data**

	Enave 240 V CF	Enave-T 240 V CF	Enave 240 VE CF	Enave-T 240 VE CF
Voltage [V / 50-60 Hz]			230	
Max. unit power without electric heater [W]			190	
Integrated electric heater power [W]	-	-	800	800
Max. unit power [W]	190	190	990	990
Max. unit current without electric heater [A]			1,4	
Integrated electric heater current [A]	-	-	3,55	3,55
Max. unit current [A]	1,4	1,4	4,95	4,95
Max air flow [m <sup>3</sup> /h]			235	
Sound pressure level at 3 m distance* [dBA]			28	
Transported air temperature [°C]			- 25...+40	
Insulation [mm]			25	
Extract filter			G4 / Coarse > 60%	
Supply filters			G4 / Coarse > 60% (option F7 / ePM1 60%)	
Connected air duct diameter [mm]			125	
Weight [kg]	20	22	20	22
Heat recovery efficiency [%]	89	83	89	83
Heat exchanger type		Counterflow		
Heat exchanger material	Polysterene	Enthalpy membrane	Polysterene	Enthalpy membrane
SEC class	A+	A	A+	A

\*Sound pressure level at 3 m distance is specified at point 4 [dBA] in average spherical free-field, for comparative use only.

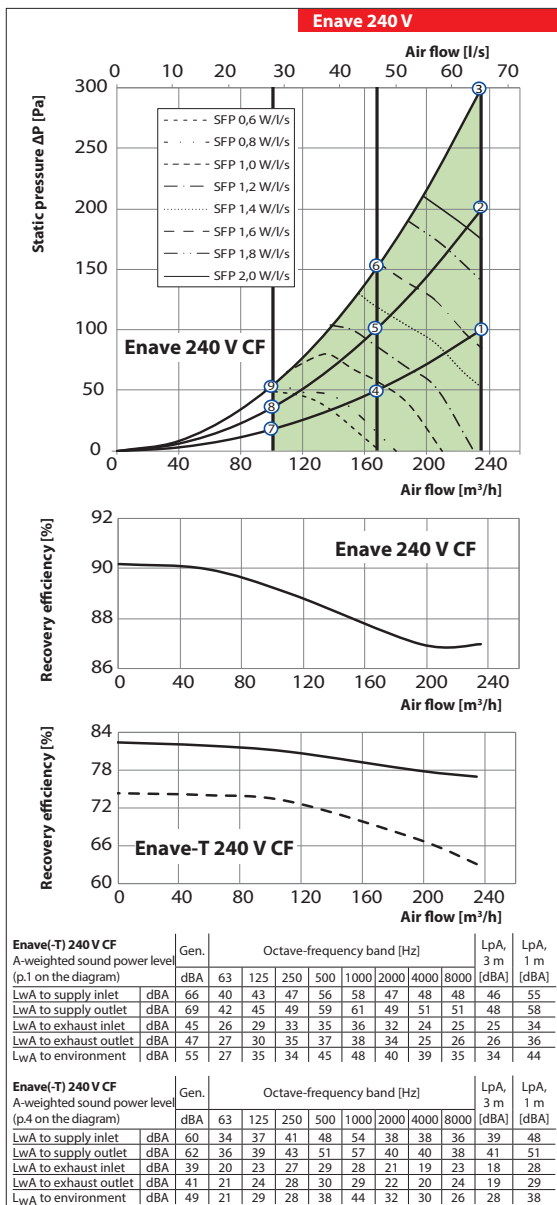

# COUNTERFLOW HEAT RECOVERY UNITS IN EPP CASING

## Technical data

	Enave 350 V	Enave-T 350 V	Enave 350 VE	Enave-T 350 VE
Voltage [V / 50-60 Hz]			230	
Max. unit power without electric heater [W]			213	
Integrated electric heater power [W]		-		1050
Max. unit power [W]	213			1263
Max. unit current without electric heater [A]			1.62	
Integrated electric heater current [A]		-		4.66
Max. unit current [A]	1.62			6.28
Max air flow [m <sup>3</sup> /h]			410	
Sound pressure level at 3 m distance* [dBA]			26	
Transported air temperature [°C]			-25...+40	
Case material			EPP	
Insulation [mm]			45	
Extract filter			Coarse > 60 %	
Supply filters			Coarse > 60 % (option ePM1 60 %)	
Connected air duct diameter [mm]			160	
Weight [kg]			26	
Heat recovery efficiency [%]	93	83	93	83
Heat exchanger type			Counter-flow	
Heat exchanger material	Polystyrene	Enthalpy membrane	Polystyrene	Enthalpy membrane
SEC class	A+	A	A+	A

\*Sound pressure level at 3 m distance is specified at point 4 [dBA] in average spherical free-field, for comparative use only.

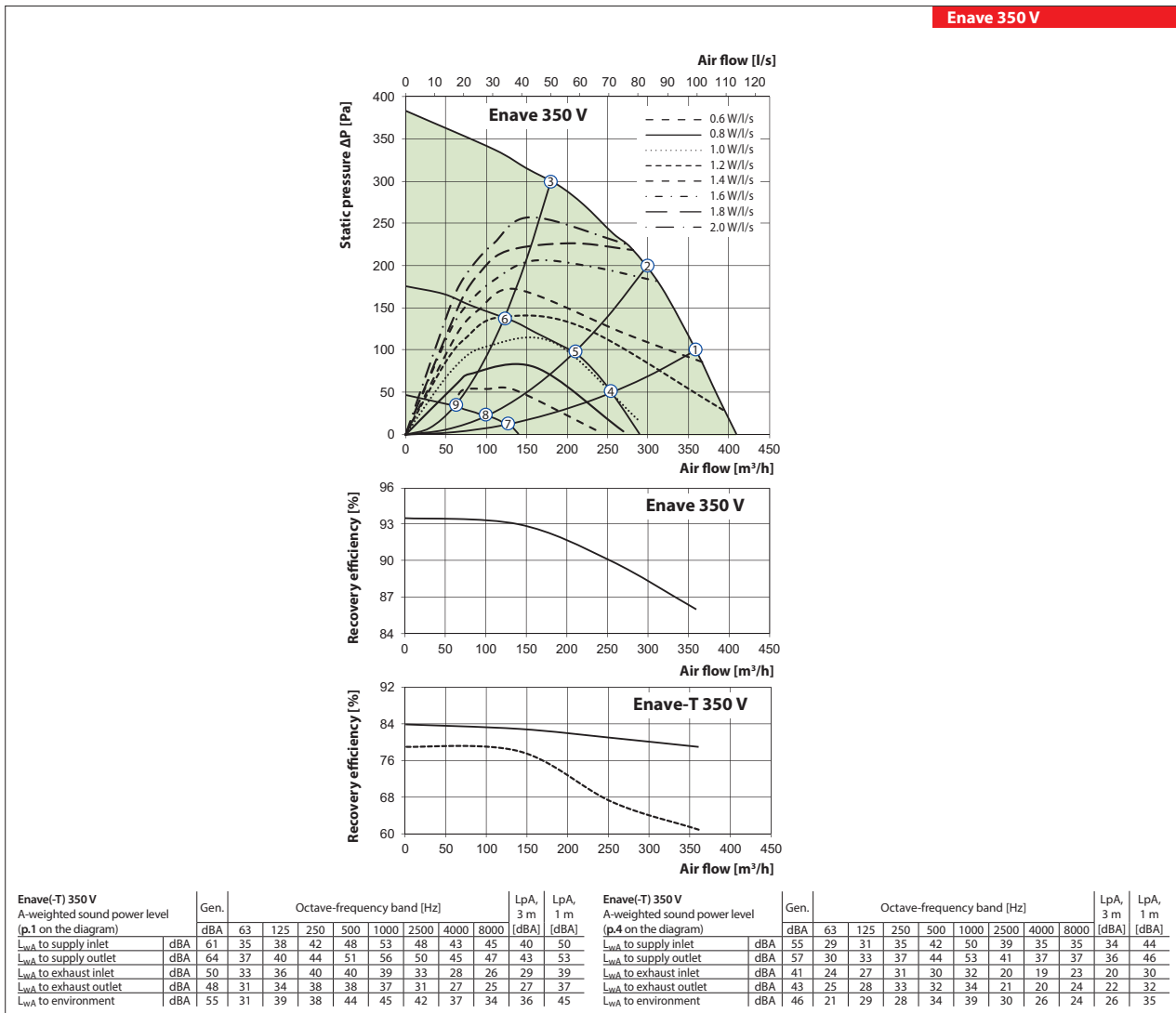

**Technical data**

	Enave 380 V CF	Enave-T 380 V CF	Enave 380 VE CF	Enave-T 380 VE CF
Voltage [V / 50-60 Hz]				230
Max. unit power without electric heater [W]				247
Integrated electric heater power [W]	-	-	1050	1050
Max. unit power [W]	247	247	1297	1297
Max. unit current without electric heater [A]	1,8	1,8	1,8	1,8
Integrated electric heater current [A]	-	-	3,55	3,55
Max. unit current [A]	1,9	1,9	5,35	5,35
Max air flow [m <sup>3</sup> /h]				390
Sound pressure level at 3 m distance* [dBA]				26
Transported air temperature [°C]				- 25...+40
Insulation [mm]				45
Extract filter				G4 / Coarse > 60%
Supply filters				G4 / Coarse > 60% (option F7 / ePM1 60%)
Connected air duct diameter [mm]				160
Weight [kg]				26
Heat recovery efficiency [%]	93	83	93	83
Heat exchanger type	Counterflow			
Heat exchanger material	Polysterene	Enthalpy membrane	Polysterene	Enthalpy membrane
SEC class	A+	A	A+	A

\*Sound pressure level at 3 m distance is specified at point 4 [dBA] in average spherical free-field, for comparative use only.

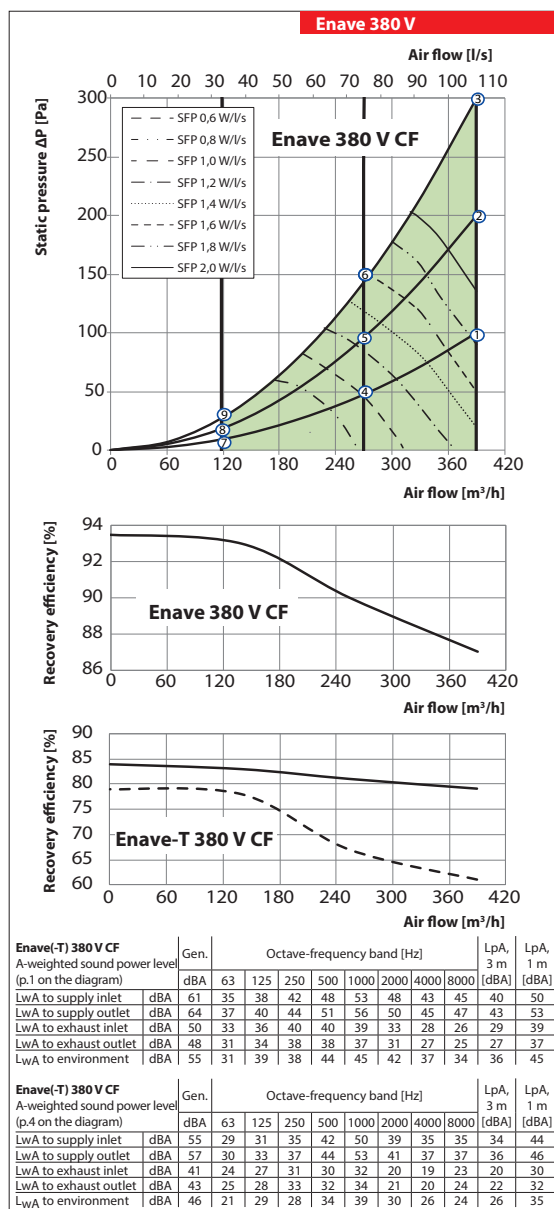

# COUNTERFLOW HEAT RECOVERY UNITS IN EPP CASING

## Technical data

	Enave 400 V	Enave-T 400 V	Enave 400 VE	Enave-T 400 VE
Voltage [V / 50-60 Hz]			230	
Max. unit power without electric heater [W]			178	
Integrated electric heater power [W]	-			1050
Max. unit power [W]	178			1228
Max. unit current without electric heater [A]		1.4		
Integrated electric heater current [A]	-			4.66
Max. unit current [A]	1.4			6.06
Max air flow [m³/h]		445		
Sound pressure level at 3 m distance [dBA]		26		
Transported air temperature [°C]		-25...+40		
Case material		EPP		
Insulation [mm]		45 mm		
Extract filter		G4 / Coarse > 60%		
Supply filters		G4 / Coarse > 60% (option F7 / ePM1 60%)		
Connected air duct diameter [mm]		160		
Weight [kg]		26		
Heat recovery efficiency [%]	93	83	93	83
Heat exchanger type	Counterflow	Counterflow	Counterflow	Counterflow
Heat exchanger material	Polysterene	Enthalpy membrane	Polysterene	Enthalpy membrane
SEC class	A+	A	A+	A

## Enave 350 V

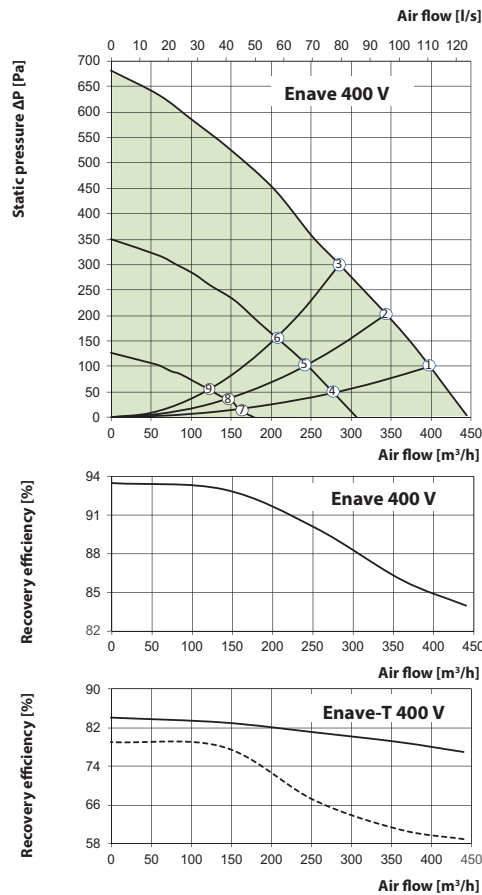

Enave(T) 400 V A-weighted sound power level (p.1 on the diagram)	Gen.	Octave-frequency band [Hz]								LpA, 3 m [dBA]	LpA, 1 m [dBA]	Enave(T) 400 V A-weighted sound power level (p.4 on the diagram)	Gen.	Octave-frequency band [Hz]								LpA, 3 m [dBA]	LpA, 1 m [dBA]	
		63	125	250	500	1000	2500	4000	8000					63	125	250	500	1000	2500	4000	8000			
L <sub>WA</sub> to supply inlet	dBA	61	35	38	42	48	53	48	43	45	40	50	dBA	55	29	31	35	42	50	39	35	35	34	44
L <sub>WA</sub> to supply outlet	dBA	64	37	40	44	51	56	50	45	47	43	53	dBA	57	30	33	37	44	53	41	37	37	36	46
L <sub>WA</sub> to exhaust inlet	dBA	50	33	36	40	40	39	33	28	26	29	39	dBA	41	24	27	31	30	32	20	19	23	20	30
L <sub>WA</sub> to exhaust outlet	dBA	48	31	34	38	38	37	31	27	25	27	37	dBA	43	25	28	33	32	34	21	20	24	22	32
L <sub>WA</sub> to environment	dBA	55	31	39	38	44	45	42	37	34	36	45	dBA	46	21	29	28	34	39	30	26	24	26	35

**Technical data**





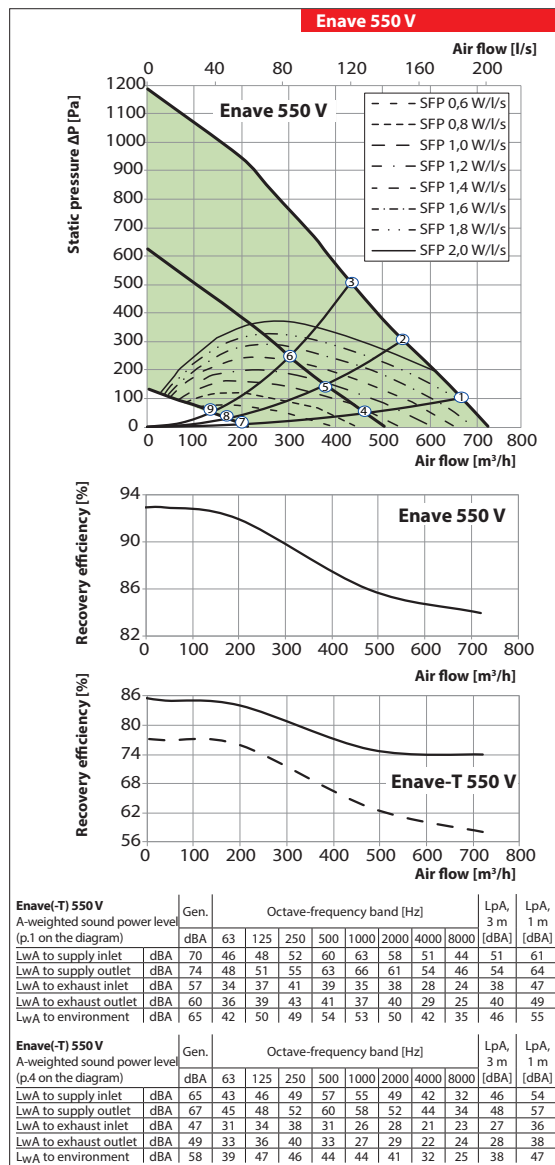

	Enave 550 V	Enave-T 550 V	Enave 550 VE	Enave-T 550 VE
Voltage [V / 50-60 Hz]	230	230	230	230
Max. unit power without electric heater [W]	346	346	346	346
Integrated electric heater power [W]	-	-	1400	1400
Max. unit power [W]	346	346	1746	1746
Max. unit current without electric heater [A]	2.4	2.4	2.4	2.4
Integrated electric heater current [A]	-	-	6.21	6.21
Max. unit current [A]	2.4	2.4	8.61	8.61
Max air flow [m <sup>3</sup> /h]			720	
Sound pressure level at 3 m distance* [dBA]			38	
Transported air temperature [°C]			- 25...+40	
Case material			EPP	
Insulation			45 mm	
Extract filter			G4 / Coarse >60 %	
Supply filters			G4 / Coarse > 60% (option F7 / ePM1 60%)	
Connected air duct diameter [mm]			200	
Weight [kg]	52	55	52.5	55.5
Heat recovery efficiency [%]	93	85	93	85
Heat exchanger type	Counterflow	Counterflow	Counterflow	Counterflow
Heat exchanger material	Polysterene	Enthalpy membrane	Polysterene	Enthalpy membrane
SEC class	A+	A	A+	A









\* Sound pressure level at 3 m distance is specified at point 4 [dBA] in average spherical free-field, for comparative use only.



## COUNTERFLOW HEAT RECOVERY UNITS IN EPP CASING

### Accessories for air handling units

	Filter G4	Filter F7	Control panel	Control panel	Wi-Fi Control panel	Internal humidity sensor	Internal CO <sub>2</sub> sensor
							
Enave 210 V A21	SF 356x100x48 Coarse 90% G4	SF 356x100x48 ePM1 65% F7	A25	A22	A22 Wi-Fi	HV2	CO2-3
Enave-T 210 V A21							
Enave 210 VE A21							
Enave-T 210 VE A21							
Enave 270 V A21							
Enave-T 270 V A21							
Enave 270 VE A21							
Enave-T 270 VE A21							
Enave 240 V A21 CF							
Enave-T 240 V A21 CF							
Enave 240 VE A21 CF							
Enave-T 240 VE A21 CF							
Enave 210 V A14							
Enave-T 210 V A14							
Enave 270 V A14							
Enave-T 270 V A14							

	External CO <sub>2</sub> sensor with indication	External CO <sub>2</sub> sensor	External humidity sensor	Electrical reheater	Syphon kit	Silencer	Air damper	Electric actuator
								
Enave 210 V A21	CO2-1	CO2-2	HR-S	NKD 125 A21 V.2	SH-32	SR 125	KRV 125	TF 230
Enave-T 210 V A21								
Enave 210 VE A21								
Enave-T 210 VE A21								
Enave 270 V A21								
Enave-T 270 V A21								
Enave 270 VE A21								
Enave-T 270 VE A21								
Enave 240 V A21 CF								
Enave-T 240 V A21 CF								
Enave 240 VE A21 CF								
Enave-T 240 VE A21 CF								
Enave 210 V A14								
Enave-T 210 V A14								
Enave 270 V A14								
Enave-T 270 V A14								

	Filter G4	Filter F7	Decorative panel	Control panel	Control panel	Wi-Fi Control panel	Internal humidity sensor	Internal CO <sub>2</sub> sensor	
Enave 350 V A21	SF 496x150x60 Coarse 90% G4	SF 496x150x60 ePM1 65% F7	-	A25	A22	A22 Wi-Fi	HV2	CO2-3	
Enave-T 350 V A21			-						
Enave 350 VE A21			-						
Enave-T 350 VE A21			-						
Enave 351 V A21			PD-Enave 351 V						
Enave-T 351 V A21			-						
Enave 351 VE A21			-						
Enave-T 351 VE A21			-						
Enave 380 V A21 CF			-						
Enave-T 380 V A21 CF			-						
Enave 380 VE A21 CF			-						
Enave-T 380 VE A21 CF			-						
Enave 381 V A21 CF			PD-Enave 351 V						
Enave-T 381 V A21 CF			-						
Enave 381 VE A21 CF			-						
Enave-T 381 VE A21 CF			-						
Enave 350 V A14			-	-	-	-	-	-	-
Enave-T 350 V A14			-	-	-	-	-	-	-
Enave 351 V A14			PD-Enave 351 V	-	-	-	-	-	-
Enave-T 351 V A14			-	-	-	-	-	-	-

## COUNTERFLOW HEAT RECOVERY UNITS IN EPP CASING

	External CO <sub>2</sub> sensor with indication	External CO <sub>2</sub> sensor	External humidity sensor	Electrical reheater	Syphon kit	Silencer	Air damper	Electric actuator
								
Enave 350 V A21	CO2-1	CO2-2	HR-S	NKD 160 A21 V.2	SH-32	SR 160	KRV 160	TF 230
Enave-T 350 V A21								
Enave 350 VE A21								
Enave-T 350 VE A21								
Enave 351 V A21								
Enave-T 351 V A21								
Enave 351 VE A21								
Enave-T 351 VE A21								
Enave 380 V A21 CF								
Enave-T 380 V A21 CF								
Enave 380 VE A21 CF								
Enave-T 380 VE A21 CF								
Enave 381 V A21 CF								
Enave-T 381 V A21 CF								
Enave 381 VE A21 CF								
Enave-T 381 VE A21 CF								
Enave 350 V A14								
Enave-T 350 V A14								
Enave 351 V A14								
Enave-T 351 V A14								

	Filter G4	Filter F7	Control panel	Control panel	Wi-Fi Control panel	Internal humidity sensor	Internal CO <sub>2</sub> sensor
Enave 550 V A21	SF 596x164x60 Coarse 90% G4	SF 596x164x60 ePM1 60% F7	A25	A22	A22 Wi-Fi	HV2	CO2-3
Enave-T 550 V A21							
Enave 550 VE A21							
Enave-T 550 VE A21			-	-	-		-
Enave 550 V A14							
Enave-T 550 V A14							

	External CO <sub>2</sub> sensor with indication	External CO <sub>2</sub> sensor	External humidity sensor	Electrical reheater	Syphon kit	Silencer	Air damper	Electric actuator
Enave 550 V A21	CO2-1	CO2-2	HR-S	NKD 200 A21 V.2	SH-32	SR 200	KRV 200	TF 230
Enave-T 550 V A21								
Enave 550 VE A21								
Enave-T 550 VE A21				-				
Enave 550 V A14								
Enave-T 550 V A14								

Series  
**VENTS VUTR 202 V EC**



Air handling units in heat- and sound-insulated casing.  
Air flow up to **270 m<sup>3</sup>/h**.  
Heat recovery efficiency up to **92%**

**Description**

The VUTR VE EC air handling units are the fully-featured ventilation units that ensure air filtration, fresh air supply and stale air extraction.

Used in ventilation that requires an economical solution and a controlled ventilation system.

**Casing**

Made of polymer-coated steel, internally filled with a mineral wool heat- and sound-insulating layer.

**VUTR 202 V EC L** – left-handed version.

**VUTR 202 V EC R** – right-handed version.

**Kitchen hood**

**VUTR 202 VK EC** is equipped with a white kitchen hood to extract contaminated air from the cooking surface. **VUTR 202 VKS EC** is equipped with a stainless steel kitchen hood.

**Filter**

Two built-in **Coarse > 60% (G4)** filters provide efficient air filtration. **ePM1 65% (F7)** supply filter can be installed as an option.

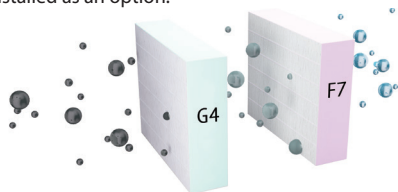

**Fans**

The units are equipped with high-efficiency EC motors with an external rotor and a centrifugal impeller.

**Rotary heat exchanger**

The units are equipped with a rotary heat exchanger. As compared to plate heat exchangers, the rotary heat exchangers are distinguished with no condensate forming, ability to maintain comfortable air humidity and extremely low freezing danger.

**VUER V** units are equipped with enthalpy rotary heat exchanger.

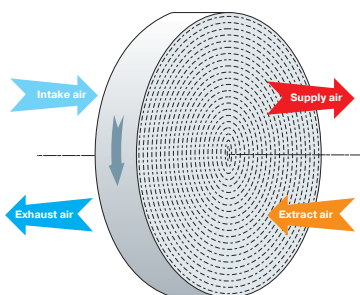

Rotary heat exchanger operation principle

**Heater**

The units **VUTR 202 VE**, **VUTR 202 VEK** are equipped with an electric heater.

**Automation**

The units are equipped with an integrated control system. The **A21** controller allows to integrate the unit into the **Smart Home system** or **BMS (Building Management System)**. To control the unit via Wi-Fi, download the **Vents Home** smartphone app.



Google play



Download on the App Store



**Decorative panel**

**PD-VUTR 202 VEK N** - stainless steel decorative panels for improving appearance of the products.



**Control and automation**

Functions	A21
	A22 (option)
Wired remote control panel	
Control via a wired remote LCD control panel	A25 (option)
Wireless remote control panel	A22 Wi-Fi (option)
BMS	ModBus RTU (RS-485) ModBus TCP/IP (Wi-Fi, Ethernet)
Vents Cloud Server service	+
Control via Wi-Fi using a smartphone app	+
Frost protection	+
Bypass	Auto, manual
Week-scheduled operation	+
Filter replacement indication	Filter timer
Alarm indication	+
Speed selection	+
Timer	+
RH% sensor	Option
CO <sub>2</sub> sensor	Option
VOC sensor	Option
PM2.5 sensor	Option
Boost mode	+
Fireplace mode	+
Fire alarm sensor connection	+
Minimum supply air temperature control	+

**Designation key**

Series	Size [m <sup>3</sup> /h/10]	Modification	Mounting	Heater	Motor	Service Side	Control panel
<b>VUTR</b> : unit with condensation rotary heat exchanger <b>VUER</b> : unit with sorption rotary heat exchanger	20	0, 1, 2...	<b>V</b> : vertical	_: w/o heater <b>E</b> : electric re-heater	<b>EC</b> : EC-motor	<b>R</b> : right <b>L</b> : left	A21

**Unit design**

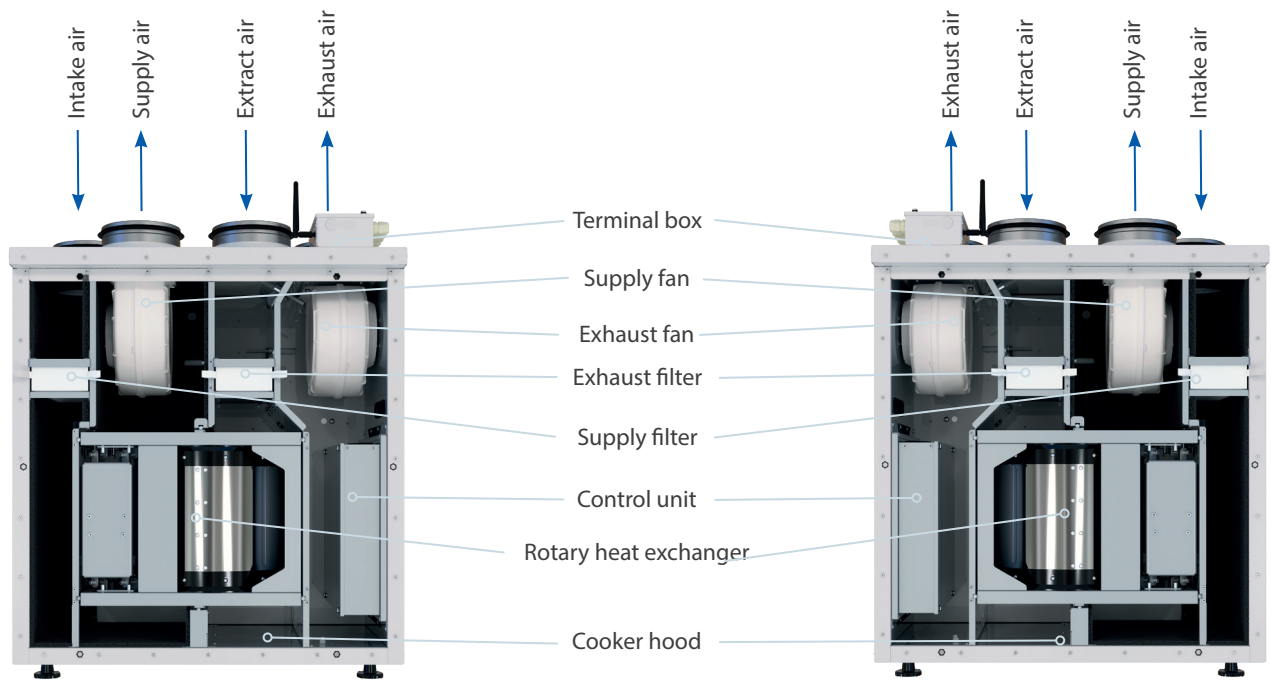

**VUTR 202 V EC L**

**VUTR 202 V EC R**

**Overall dimensions**

Model	Dimensions [mm]					
	H	W	W1	W2	L	L1
<b>VUTR 202 V EC</b>	630	596	408	173	338	-
<b>VUTR 202 VK EC</b>	746	596	408	173	326	338

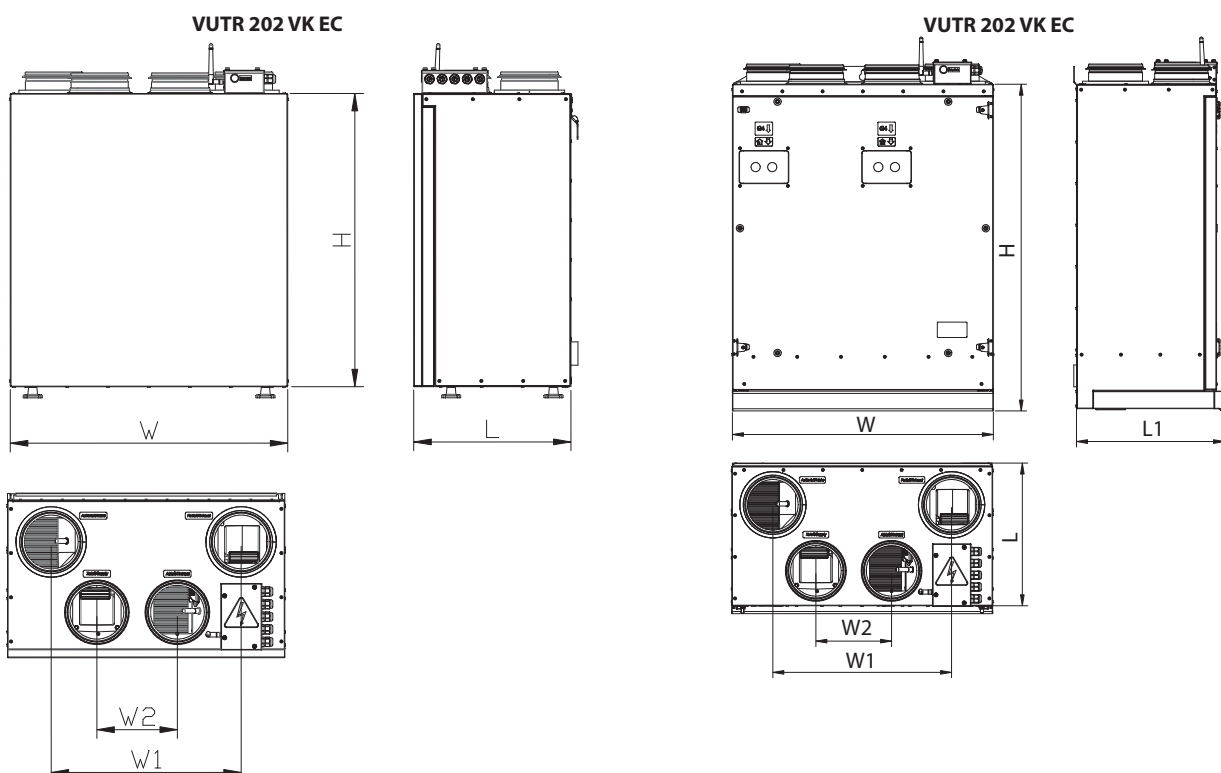

## ROTARY HEAT RECOVERY UNITS

### Technical data

	VUTR 202 V EC L / R A21	VUER 202 V EC L / R A21	VUTR 202 VE EC L / R A21	VUER 202 VE EC L / R A21
Voltage [V / 50-60 Hz]	1~ 230			
Max. unit power without electric heater [W]	187			
Integrated electric heater power [W]	-		700	
Max. unit power [W]	187		887	
Max. unit current without electric heater [A]	1.1			
Integrated electric heater current [A]	-		3.1	
Max. unit current [A]	1.1		4.2	
Max air flow [m <sup>3</sup> /h]	250			
Sound pressure level at 3 m distance* [dBA]	24			
Transported air temperature [°C]	from -25 up to +40			
Case material	painted steel			
Insulation	25 mm, mineral wool			
Extract filter	G4 / Coarse > 60%			
Supply filter	G4 / Coarse > 60% (option F7 / ePM1 60%)			
Connected air duct diameter [mm]	125			
Weight [kg]	46			
Heat recovery efficiency [%]	93		86	
Heat exchanger type	condensing		enthalpy	
SEC class	A			

\*Sound pressure level [dBA] at 3 m distance is specified at point 4 in average spherical free-field, for comparative use only.

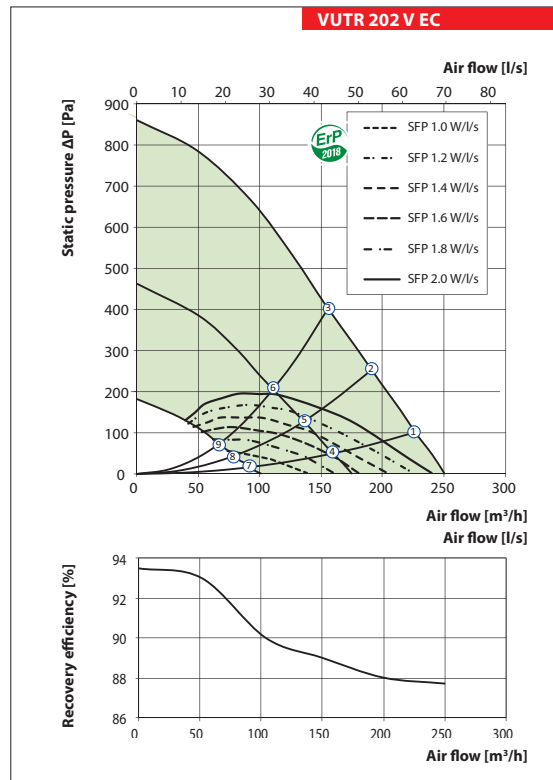

**Technical data**





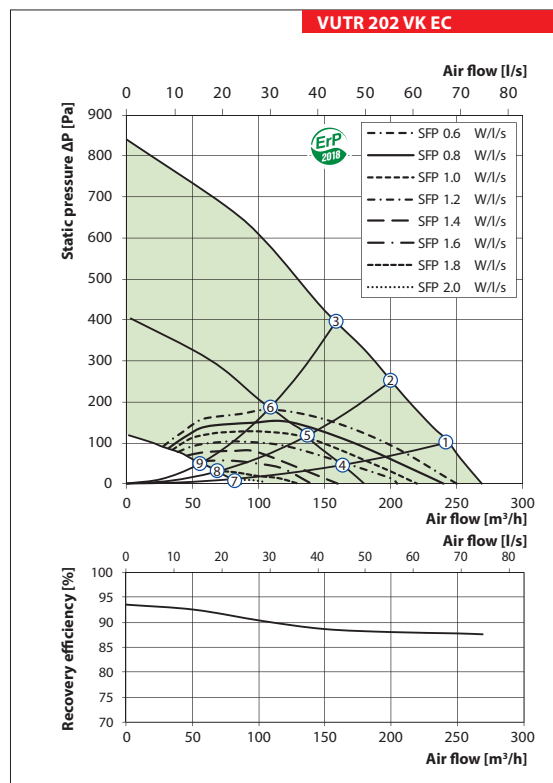

	VUTR 202 VK EC A21	VUTR 202 VEK EC A21
Voltage [V / 50-60 Hz]		1~230
Max. unit power without electric heater [W]		171
Integrated electric heater power [W]	-	700
Max. unit power [W]	171	871
Max. unit current without electric heater [A]		1.31
Integrated electric heater current [A]	-	3
Max. unit current [A]	1.31	4.31
Max air flow [m <sup>3</sup> /h]		270
Sound pressure level at 3 m distance* [dBA]		33
Transported air temperature [°C]		- 25...+40
Case material		polymer coated steel
Insulation [mm]		25 mm, mineral wool
Extract filter		G4
Supply filters		G4 (F7 optional)
Connected air duct diameter [mm]		125
Weight [kg]	52	53
Heat recovery efficiency [%]		87...93
Heat exchanger type		rotary
Heat exchanger material		aluminum
SEC class		A





\*Sound pressure level [dBA] at 3 m distance is specified at point 4 in average spherical free-field, for comparative use only.







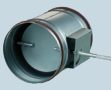

## ROTARY HEAT RECOVERY UNITS

### Accessories for air handling units

Model	Filter G4	Filter F7	Control panel	Control panel	Wi-Fi Control panel	Internal CO2 sensor	External humidity sensor
							
VUTR 202 V EC L/R A21	SF 261x86x48 G4	SF 261x86x48 F7	A25	A22	A22 Wi-Fi	CO2-3	HR-S
VUER 202 V EC L/R A21							
VUTR 202 VE EC L/R A21							
VUER 202 VE EC L/R A21							

Model	External CO2 sensor	Silencer	Internal humidity sensor	Air dampers	Electric actuator
					
VUTR 202 V EC L/R A21	CO2-1	SR 125	HV-2	KRV 125	TF230
VUER 202 V EC L/R A21					
VUTR 202 VE EC L/R A21					
VUER 202 VE EC L/R A21					

### Accessories for air handling units

Model	Decorative panel	Filter G4	Filter F7	Control panel	Control panel	Wi-Fi Control panel	External humidity sensor
							
VUTR 202 VK(S) EC L/R A21	PD-VUTR 200 VEK N	SF 261x86x48 G4	SF 261x86x48 F7	A25	A22	A22 Wi-Fi	HR-S
VUTR 202 VEK(S) EC L/R A21							

Model	External CO2 sensor	Silencer	Backdraught damper	Air dampers	Electric actuator
					
VUTR 202 VK(S) EC L/R A21	CO2-1	SR 125	KOM 125	KRV 125	TF230
VUTR 202 VEK(S) EC L/R A21					



Series  
**VENTS VUTR V EC**



Air handling units in heat- and sound-insulated casing.  
Air flow up to **747 m<sup>3</sup>/h**.  
Heat recovery efficiency up to 89 %.

**Description**

The **VUTR VE EC** air handling units are the fully-featured ventilation units that ensure air filtration, fresh air supply and stale air extraction. Used in ventilation that require an economical solution and a controlled ventilation system.

**Casing**

Made of polymer-coated steel, internally filled with a mineral wool heat- and sound-insulating layer.  
**VUTR V ECL** – left-handed version.  
**VUTR V ECR** – right-handed version.

**Filter**

Two built-in Coarse 90% (G4) filters provide efficient air filtration. ePM1 65% (F7) supply filter can be installed as an option.

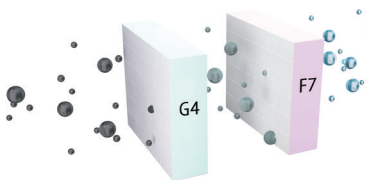

**Fans**

The units are equipped with high-efficiency EC motors with an external rotor and a centrifugal impeller.

**Rotary heat exchanger**

The units are equipped with a rotary heat exchanger. **VUTR V** units are equipped with condensing rotary heat exchanger. **VUER V** units are equipped with enthalpy rotary heat exchanger.

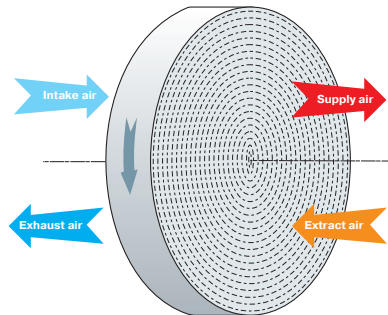

Rotary heat exchanger operation principle

**Heater**

The units **VUTR VE** are equipped with an electric heater.

**Automation**

The units are equipped with an integrated control system. The **A21** controller allows to integrate the unit into the **Smart Home system** or **BMS (Building Management System)**. To control the unit via Wi-Fi, download the **Vents Home** smartphone app.



**Control and automation**

Functions	A21
	A22 (option)
Wired remote control panel	
	A25 (option)
Control via a wired remote LCD control panel	
	A22 Wi-Fi (option)
Wireless remote control panel	
BMS	ModBus RTU (RS-485) ModBus TCP/IP (Wi-Fi, Ethernet)
Vents Cloud Server service	+
Control via Wi-Fi using a smartphone app	+
Frost protection	+
Bypass	Auto, manual
Week-scheduled operation	+
Filter replacement indication	Filter timer
Alarm indication	+
Speed selection	+
Timer	+
RH% sensor	Option
CO <sub>2</sub> sensor	Option
VOC sensor	Option
PM2.5 sensor	Option
Boost mode	+
Fireplace mode	+
Fire alarm sensor connection	+
Minimum supply air temperature control	+

**Designation key**

Series	Size [m <sup>3</sup> /h/10]	Modification	Mounting	Heater	Motor	Service Side	Control panel
<b>VUTR</b> : unit with condensation rotary heat exchanger <b>VUER</b> : unit with enthalpy rotary heat exchanger	28.40.60	0, 1, 2...	<b>V</b> : vertical	–: w/o heater <b>E</b> : electric re-heater	<b>EC</b> : EC-motor	<b>R</b> : right <b>L</b> : left	A21

**Unit design**

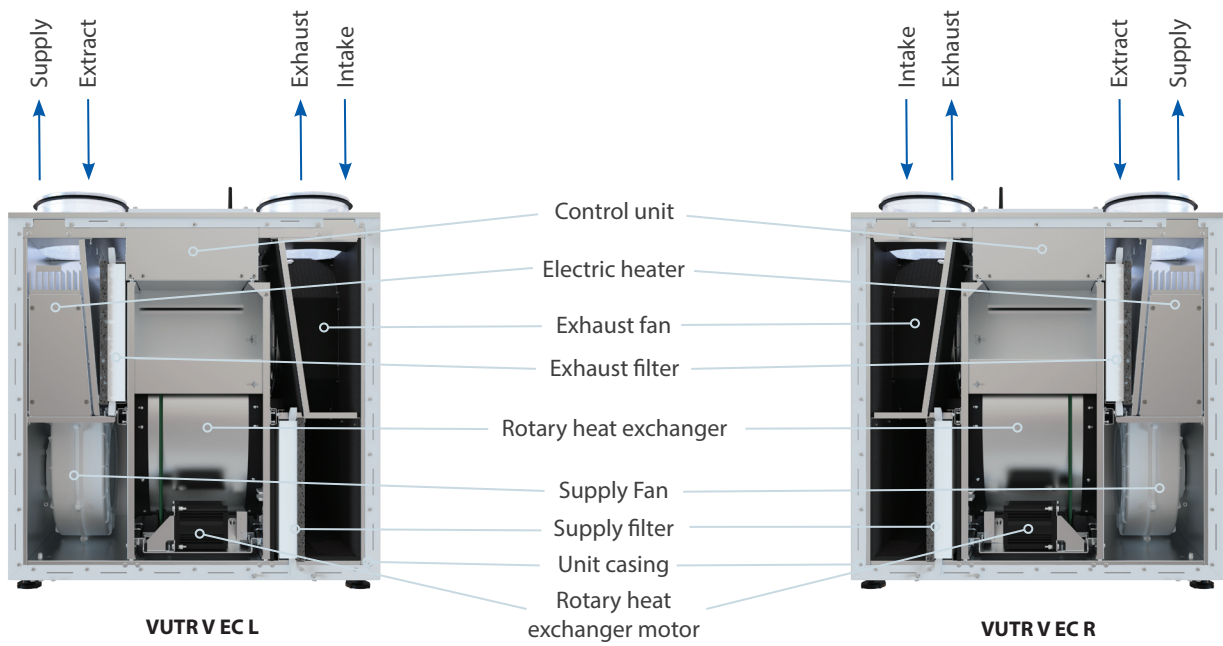

**Overall dimensions**

Model	Dimensions [mm]						
	H	W	L	H1	W1	L1	D
<b>VUTR 281 V EC</b> <b>VUTR 401 V EC</b>	588	598	515	638	397	209	160

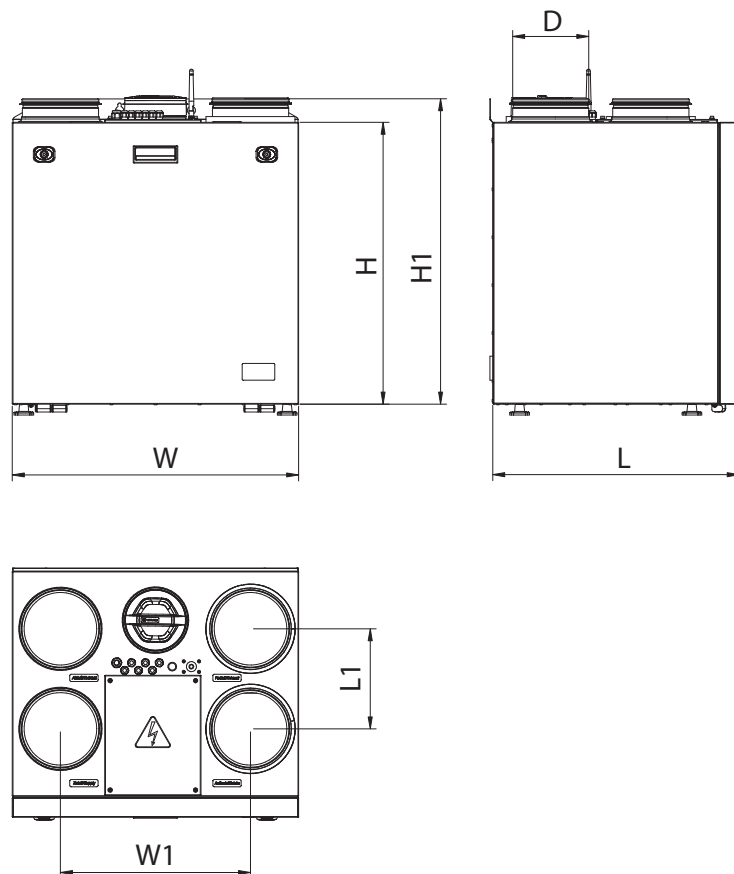

Unit design

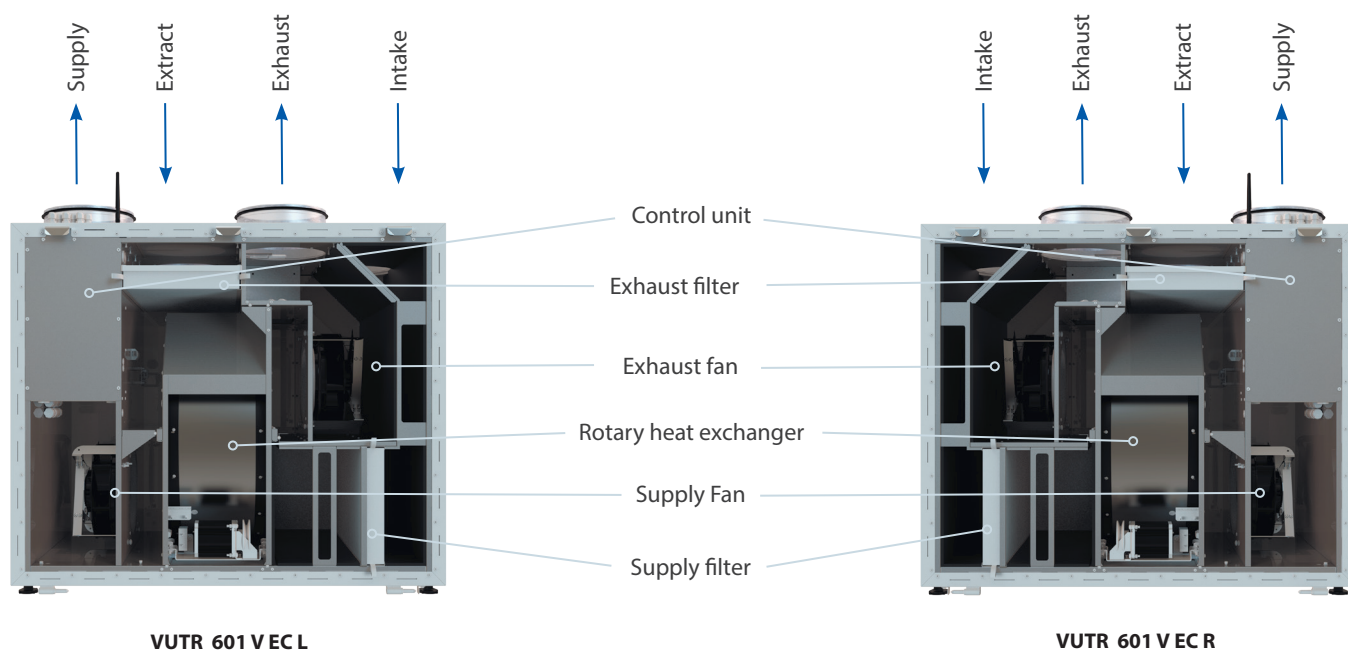

VUTR 601 V E C L

VUTR 601 V E C R

Overall dimensions

Model	Dimensions [mm]										
	H	W	L	H1	W1	W2	W3	L1	L2	D	D1
VUTR 601 V E C	750	900	609	828	427	192	140	248	167	200	125

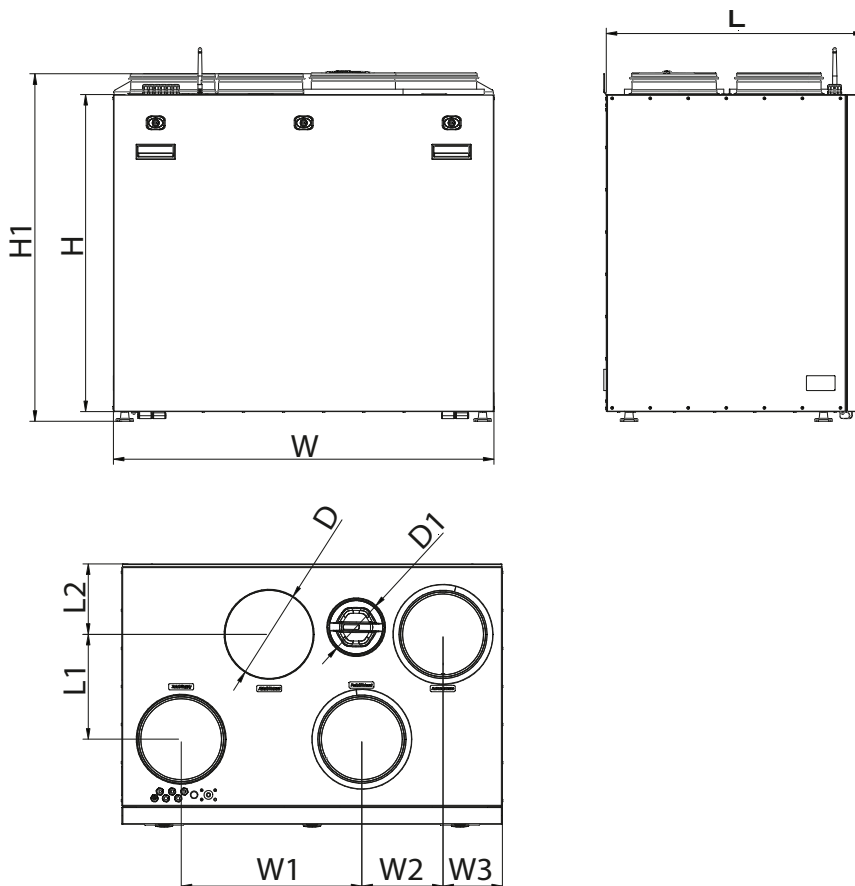

**Technical data**

Model	VUTR 281 V EC A21	VUER 281 V EC A21	VUTR 281 VE EC A21	VUER 281 VE EC A21	VUTR 401 V EC A21	VUER 401 V EC A21	VUTR 401 VE EC A21	VUER 401 VE EC A21
Voltage [V / 50-60 Hz]	230							
Max. unit power without electric heater [W]	179				257			
Integrated electric heater power [W]	-	-	1200	1200	-	-	1200	1200
Max. unit power [W]	179	179	1379	1379	257	257	1457	1457
Max. unit current without electric heater [A]	1.34	1.34	1.34	1.34	1.76	1.76	1.76	1.76
Integrated electric heater current [A]	-	-	5.32	5.32	-	-	5.32	5.32
Max. unit current [A]	1.34	1.34	6.66	6.66	1.76	1.76	7.08	7.08
Max air flow [m³/h]	382	382	382	382	447	447	447	447
Sound pressure level at 3 m distance* [dBA]	26	26	26	26	28	28	28	28
Transported air temperature [°C]	- 25...+40							
Case material	painted steel							
Insulation	40							
Extract filter	G4 / Coarse > 60%							
Supply filters	G4 / Coarse > 60% (option F7 / ePM1 60%)							
Connected air duct diameter [mm]	160							
Weight [kg]	57				58			
Heat recovery efficiency [%]	89	86	89	86	89	85	89	85
Heat exchanger type	condensing	enthalpy	condensing	enthalpy	condensing	enthalpy	condensing	enthalpy
SEC class	A+	A+	A+	A+	A+	A	A+	A

\* Sound pressure level [dBA] at 3 m distance is specified at point 4 in average spherical free-field, for comparative use only.

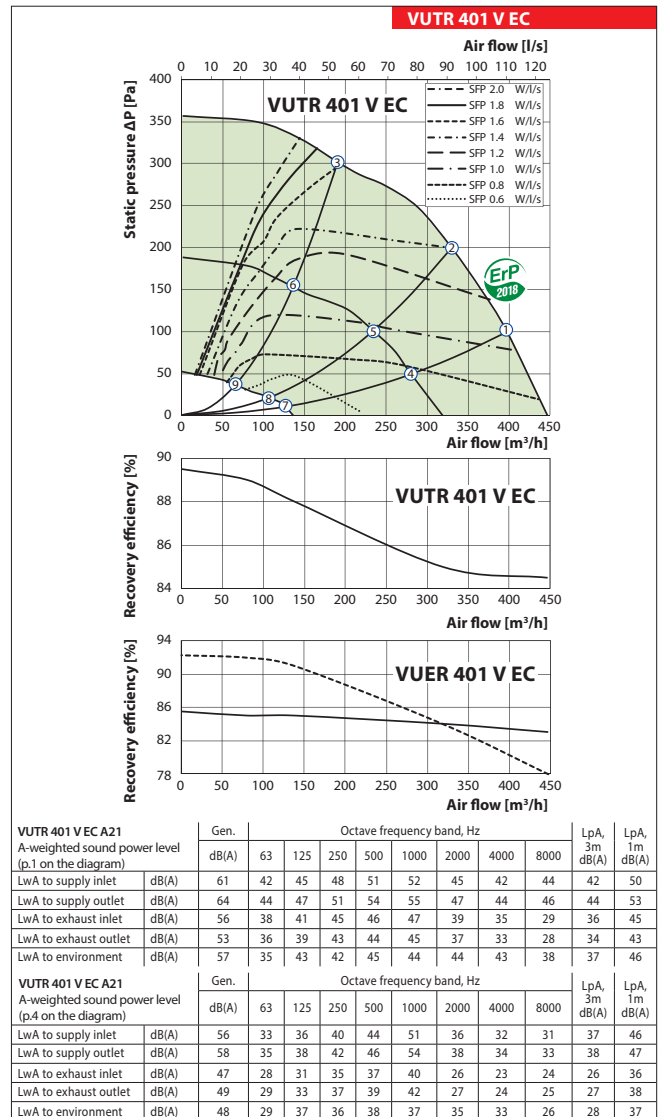
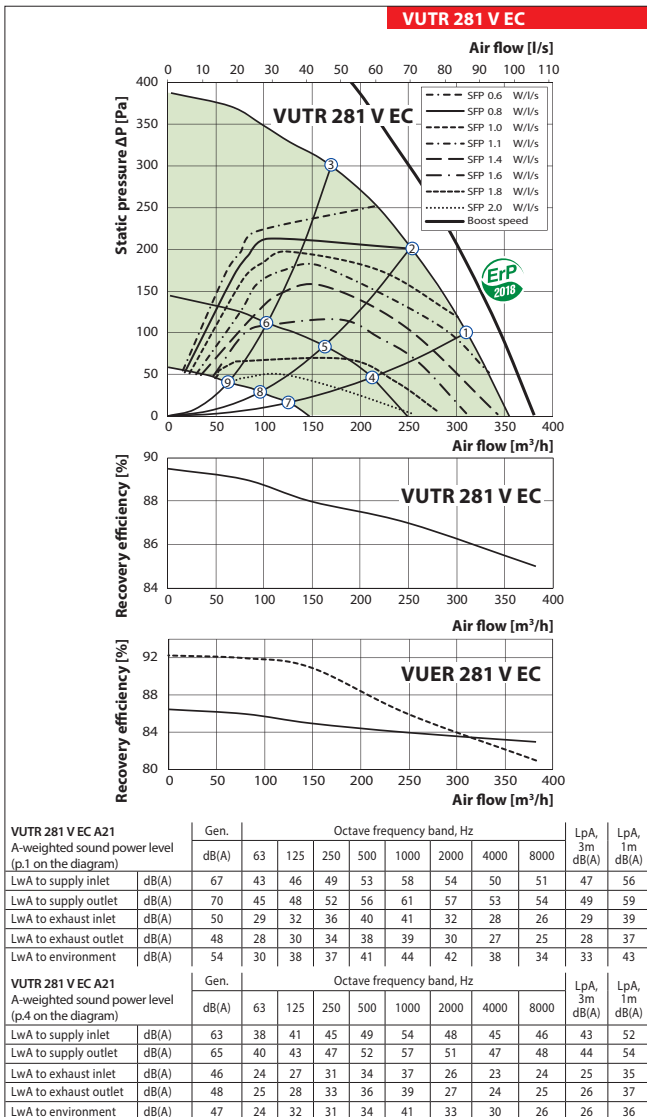

Technical data

Model	VUTR 601 V EC L / R A21	VUER 601 V EC L / R A21	VUTR 601 VE EC L / R A21	VUER 601 VE EC L / R A21
Voltage [V / 50-60 Hz]			230	
Max. unit power without electric heater [W]			336	
Integrated electric heater power [W]	-	-	1400	1400
Max. unit power [W]	336	336	1736	1736
Max. unit current without electric heater [A]	2.3	2.3	2.3	2.3
Integrated electric heater current [A]	-	-	6.21	6.21
Max. unit current [A]	2.3	2.3	8.51	8.51
Max air flow [m³/h]			747	
Sound pressure level at 3 m distance* [dBA]			29	
Transported air temperature [°C]			- 25...+40	
Case material			painting steel	
Insulation			40	
Extract filter			G4 / Coarse > 60%	
Supply filters			G4 / Coarse > 60% (option F7 / ePM1 60%)	
Connected air duct diameter [mm]			200	
Weight [kg]			90	
Heat recovery efficiency [%]	87	86	87	86
Heat exchanger type	condensing	enthalpy	condensing	enthalpy
SEC class	A+	A+	A+	A+

\* Sound pressure level [dBA] at 3 m distance is specified at point 4 in average spherical free-field, for comparative use only.

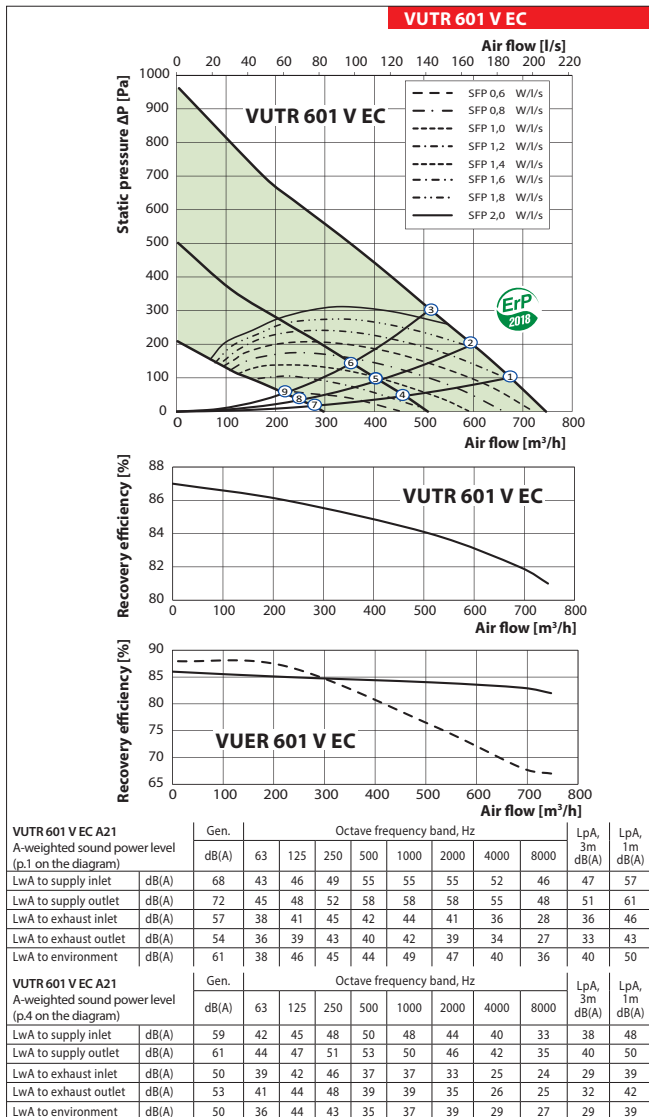

**Accessories for air handling units**

	Filter G4	Supply filter F7	Control panel	Control panel	WiFi Control panel	Internal humidity sensor	Internal CO <sub>2</sub> sensor
VUTR 281 V EC A21	SF 428 x 220 x 40 Coarse 90% G4	SF 428 x 220 x 40 ePM1 60% F7	A25	A22	A22 Wi-Fi	HV2	CO2-3
VUTR 281 VE EC A21							
VUER 281 V EC A21							
VUER 281 VE EC A21							
VUTR 401 V EC A21							
VUTR 401 VE EC A21							
VUER 401 V EC A21							
VUER 401 VE EC A21							
VUTR 601 V EC A21	SF 522x240x48 Coarse 90% G4	SF 522x240x48 ePM1 60% F7					
VUTR 601 VE EC A21							

	External CO <sub>2</sub> sensor with indication	External humidity sensor	Silencer	Air damper	Electric actuator
VUTR 281 V EC A21	CO2-1	HR-S	SR 160	KRV 160	TF 230
VUTR 281 VE EC A21					
VUER 281 V EC A21					
VUER 281 VE EC A21					
VUTR 401 V EC A21					
VUTR 401 VE EC A21					
VUER 401 V EC A21					
VUER 401 VE EC A21					
VUTR 601 V EC A21			SR 200	KRV 200	
VUTR 601 VE EC A21					

Series  
**VENTS VUTR P EC**



Air handling units in heat- and sound-insulated casing.  
Air flow up to **798 m<sup>3</sup>/h**.  
Heat recovery efficiency up to 88 %.

**Description**

The **VUTR P EC** air handling units are the fully-featured ventilation units that ensure air filtration, fresh air supply and stale air extraction. Used in ventilation that require an economical solution and a controlled ventilation system.

**Casing**

Made of polymer-coated steel, internally filled with a mineral wool heat- and sound-insulating layer.  
**VUTR P ECL** – left-handed version.  
**VUTR P ECR** – right-handed version.

**Filter**

Two built-in Coarse 90% (G4) filters provide efficient air filtration. ePM1 60% (F7) supply filter can be installed as an option.

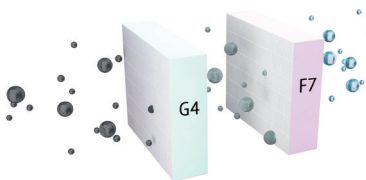

**Fans**

The units are equipped with high-efficiency EC motors with an external rotor and a centrifugal impeller.

**Rotary heat exchanger**

The units are equipped with a rotary heat exchanger. **VUTR P** units are equipped with condensing rotary heat exchanger. **VUER P** units are equipped with enthalpy rotary heat exchanger.

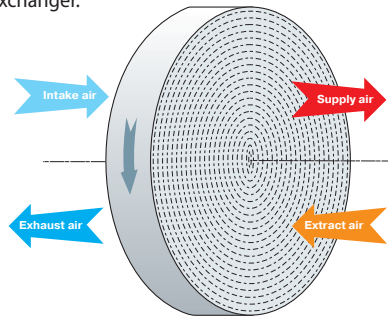

Rotary heat exchanger operation principle

**Heater**

The units **VUTR PE** are equipped with an electric heater.

**Automation**

The units are equipped with an integrated control system. The **A21** controller allows to integrate the unit into the **Smart Home system** or **BMS (Building Management System)**. To control the unit via Wi-Fi, download the **Vents Home** smartphone app.



**Control and automation**

Functions	A21
	A22 (option)
Wired remote control panel	
	A25 (option)
Control via a wired remote LCD control panel	
	A22 Wi-Fi (option)
Wireless remote control panel	
BMS	ModBus RTU (RS-485) ModBus TCP/IP (Wi-Fi, Ethernet)
Vents Cloud Server service	+
Control via Wi-Fi using a smartphone app	+
Frost protection	+
Bypass	Auto, manual
Week-scheduled operation	+
Filter replacement indication	Filter timer
Alarm indication	+
Speed selection	+
Timer	+
RH% sensor	Option
CO <sub>2</sub> sensor	Option
VOC sensor	Option
PM2.5 sensor	Option
Boost mode	+
Fireplace mode	+
Fire alarm sensor connection	+
Minimum supply air temperature control	+

**Designation key**

Series	Size	Modification	Mounting	Heater	Motor	Service Side	Control panel
<b>VUTR</b> : unit with condensation rotary heat exchanger <b>VUER</b> : unit with enthalpy rotary heat exchanger	m <sup>3</sup> /h/10	0, 1, 2...	<b>P</b> : suspended	–: w/o heater <b>E</b> : electric re-heater	<b>EC</b> : EC-motor	<b>R</b> : right <b>L</b> : left	A21

**Unit design**

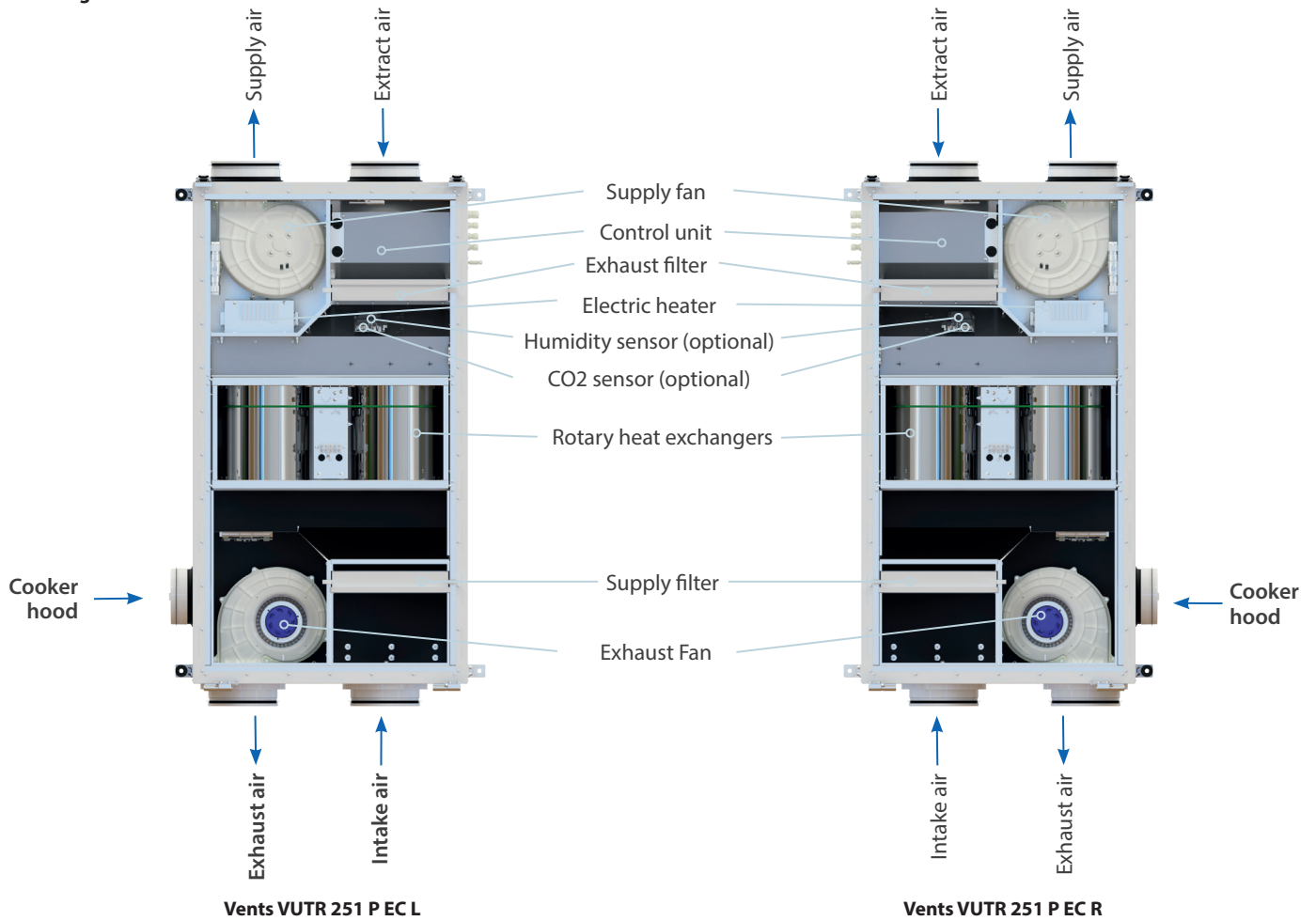

**Overall dimensions**

Model	Dimensions [mm]								
	H	W	L	H1	W1	L1	D	D1	
<b>Vents VUTR 251 P EC</b>	280	630	1150	155	319	200	160	125	

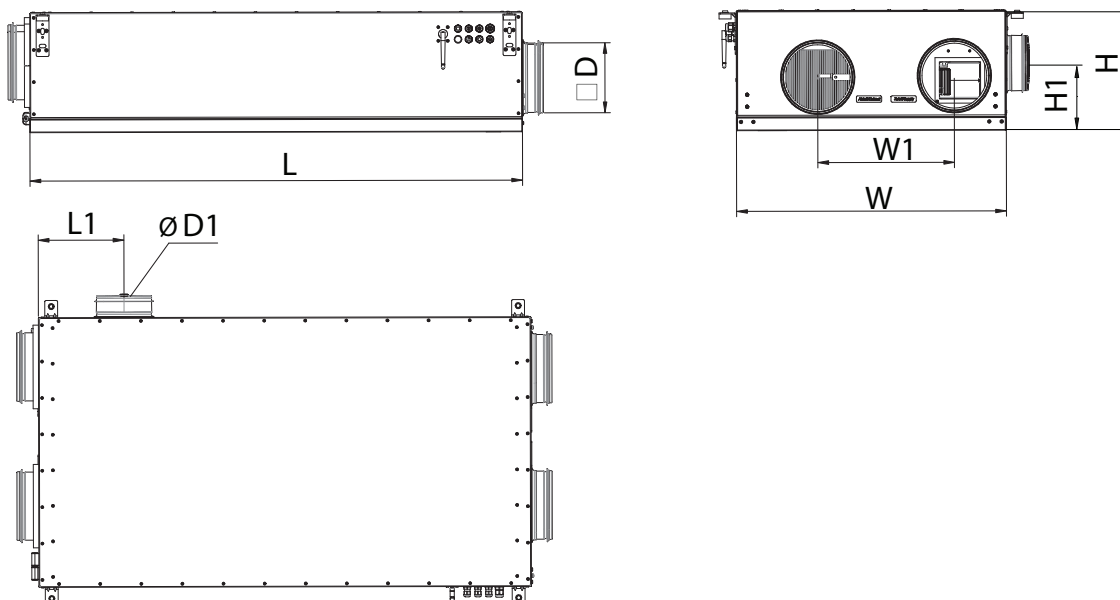

# ROTARY HEAT RECOVERY UNITS

## Unit design

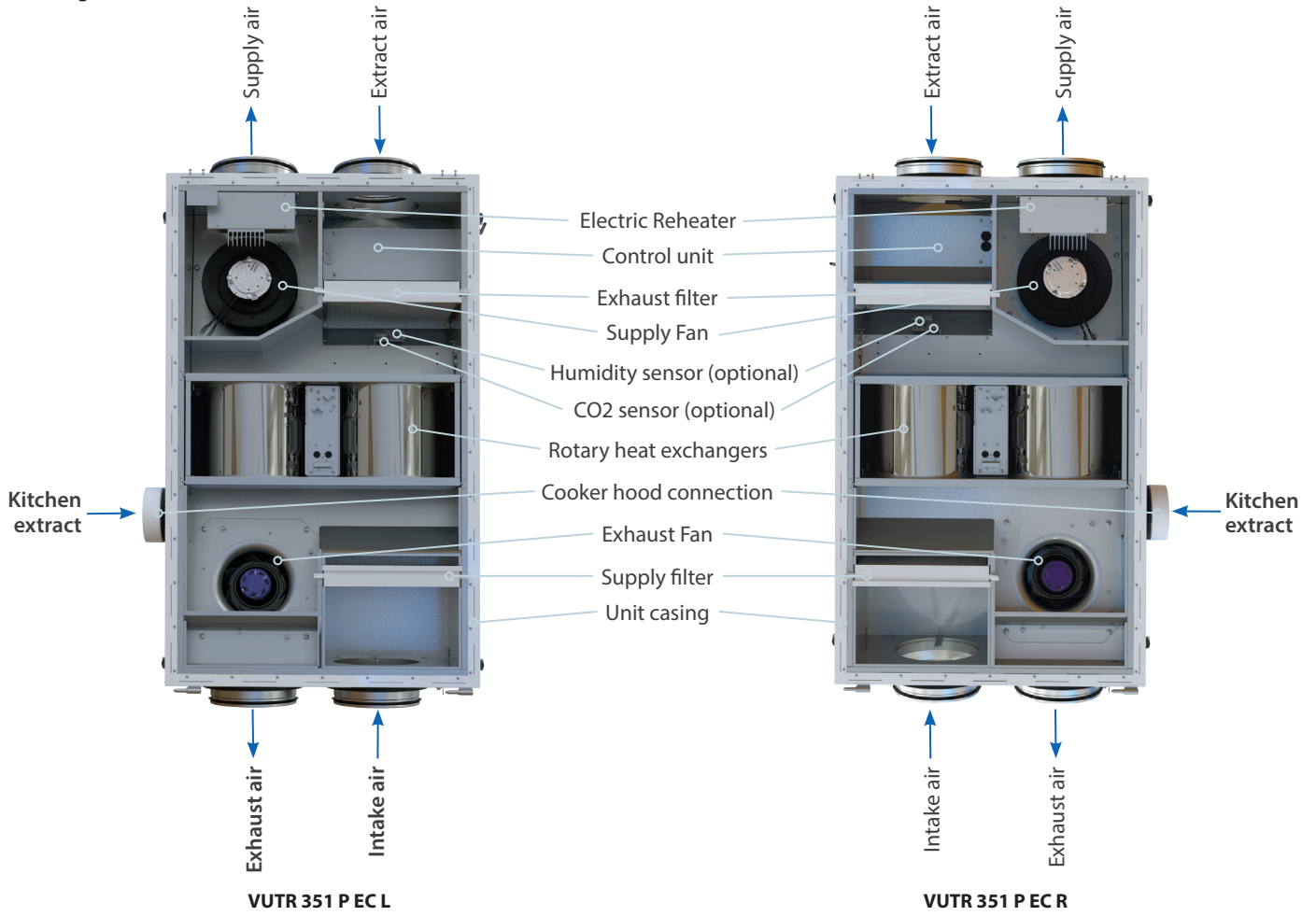

## Overall dimensions

Model	Dimensions [mm]							
	H	W	L	H1	W1	L1	D	D1
<b>VUTR 351 P EC</b>	308	700	1170	106	285	387	200	125

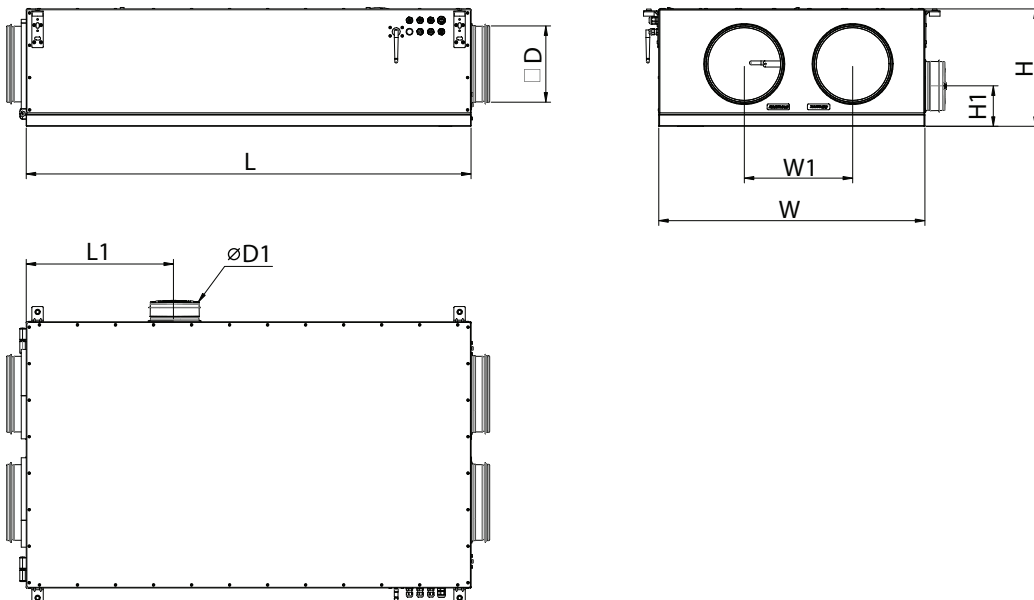

**Unit design**

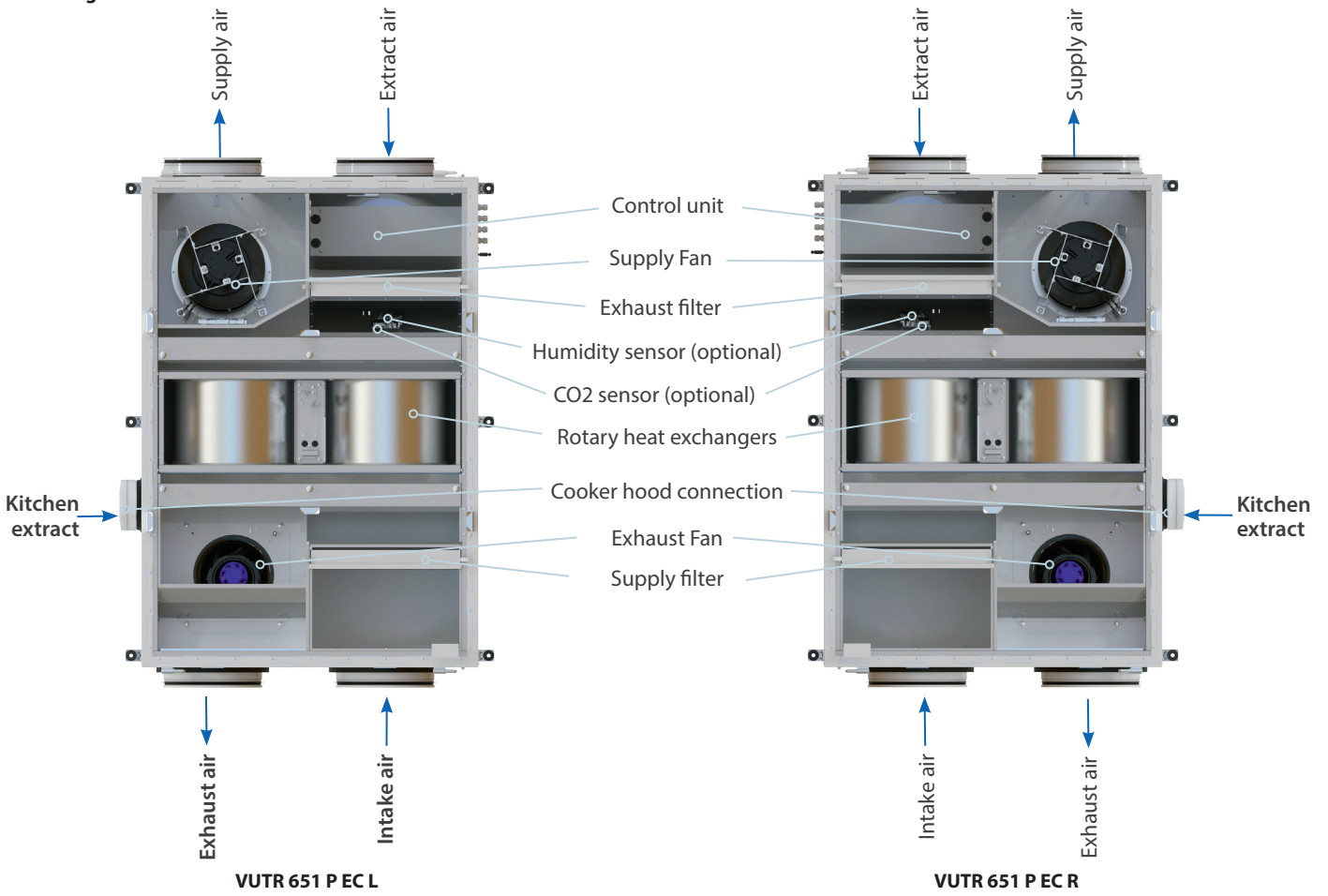

**Overall dimensions**

Model	Dimensions [mm]							
	H	W	L	H1	W1	L1	D	D1
VUTR 651 P EC	425	850	1240	136	435	410	250	125

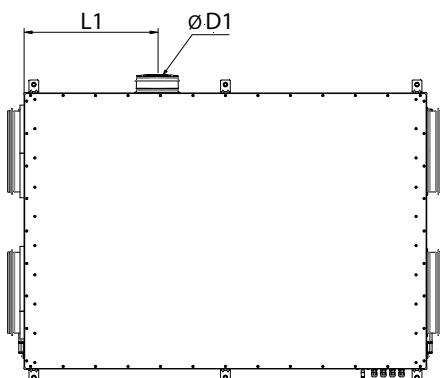
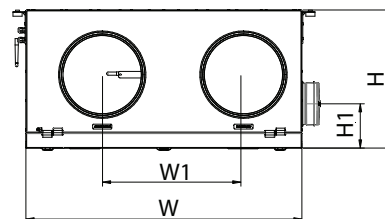
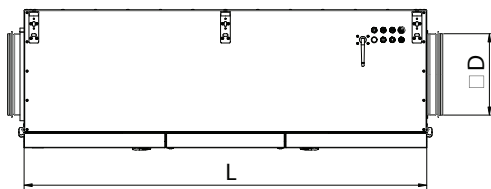

## ROTARY HEAT RECOVERY UNITS

### Technical data

	VUTR 251 P EC A21	VUER 251 P EC A21	VUTR 251 PE EC A21	VUER 251 PE EC A21
Voltage [V / 50-60 Hz]	230	230	230	230
Max. unit power without electric heater [W]	183	183	183	183
Integrated electric heater power [W]	-	-	800	800
Max. unit power [W]	183	183	983	983
Max. unit current without electric heater [A]	1,4	1,4	1,4	1,4
Integrated electric heater current [A]	-	-	3,55	3,55
Max. unit current [A]	1,4	1,4	4,95	4,95
Max air flow [m <sup>3</sup> /h]	348	348	348	348
Sound pressure level at 3 m distance* [dBA]	23	23	23	23
Transported air temperature [°C]	- 25...+40	- 25...+40	- 25...+40	- 25...+40
Case material	painted steel	painted steel	painted steel	painted steel
Insulation	40	40	40	40
Extract filter	G4 / Coarse > 60%	G4 / Coarse > 60%	G4 / Coarse > 60%	G4 / Coarse > 60%
Supply filters	G4 / Coarse > 60% (option F7 / ePM1 60%)	G4 / Coarse > 60% (option F7 / ePM1 60%)	G4 / Coarse > 60% (option F7 / ePM1 60%)	G4 / Coarse > 60% (option F7 / ePM1 60%)
Connected air duct diameter [mm]	160	160	160	160
Weight [kg]	61,5	62	61,5	62
Heat recovery efficiency [%]	84	82	84	82
Heat exchanger type	condensing	enthalpy	condensing	enthalpy
SEC class	A	A	A	A

\*Sound pressure level [dBA] at 3 m distance is specified at point 4 in average spherical free-field, for comparative use only

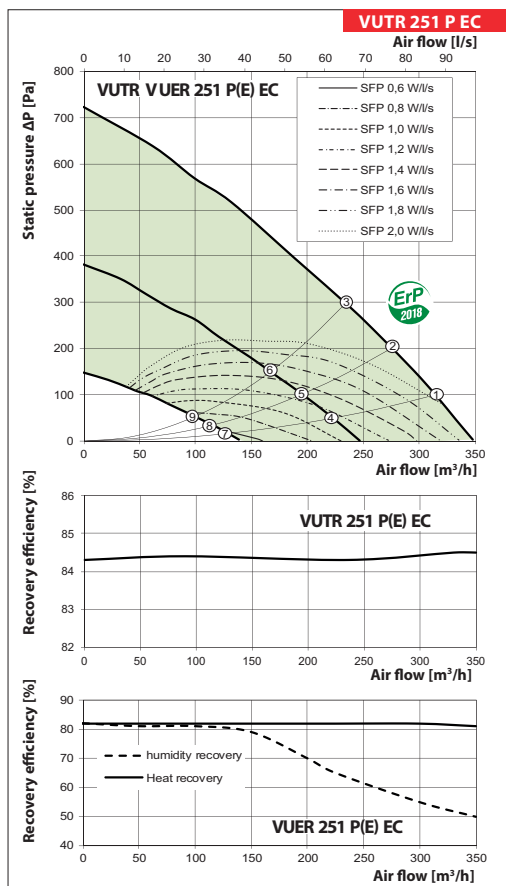

VUTR 251 P EC Sound-power level, A - weighted (p.1 on the diagram)	General dB(A)	Octave frequency band, Hz								LpA, 3m dB(A)	LpA, 1m dB(A)
		63	125	250	500	1000	2000	4000	8000		
LwA to supply inlet	67	43	46	49	58	60	52	49	49	48	57
LwA to supply outlet	71	45	48	52	61	63	55	52	52	50	60
LwA to exhaust inlet	49	34	37	41	39	30	31	26	25	29	38
LwA to exhaust outlet	51	36	39	43	41	32	33	27	26	30	40
LwA to environment	51	33	41	40	42	40	38	33	36	31	40

VUTR 251 P EC Sound-power level, A - weighted (p.4 on the diagram)	General dB(A)	Octave frequency band, Hz								LpA, 3m dB(A)	LpA, 1m dB(A)
		63	125	250	500	1000	2000	4000	8000		
LwA to supply inlet	62	37	40	44	50	55	44	41	41	41	50
LwA to supply outlet	64	39	42	46	53	58	46	43	43	43	53
LwA to exhaust inlet	42	27	30	34	32	23	23	20	24	22	31
LwA to exhaust outlet	44	28	32	36	34	24	24	21	25	23	33
LwA to environment	44	26	34	33	34	34	29	25	27	23	33

**Technical data**

	VUTR 351 P EC A21	VUER 351 P EC A21	VUTR 351 PE EC A21	VUER 351 PE EC A21
Voltage [V / 50-60 Hz]	230	230	230	230
Max. unit power without electric heater [W]	247	247	247	247
Integrated electric heater power [W]	-	-	1200	1200
Max. unit power [W]	247	247	1447	1447
Max. unit current without electric heater [A]	1,62	1,62	1,62	1,62
Integrated electric heater current [A]	-	-	5,32	5,32
Max. unit current [A]	1,62	1,62	6,94	6,94
Max air flow [m <sup>3</sup> /h]	513	513	513	513
Sound pressure level at 3 m distance* [dBA]	31	31	31	31
Transported air temperature [°C]	- 25...+40	- 25...+40	- 25...+40	- 25...+40
Case material	painted steel	painted steel	painted steel	painted steel
Insulation	40	40	40	40
Extract filter	G4 / Coarse > 60%	G4 / Coarse > 60%	G4 / Coarse > 60%	G4 / Coarse > 60%
Supply filters	G4 / Coarse > 60% (option F7 / ePM1 60%)	G4 / Coarse > 60% (option F7 / ePM1 60%)	G4 / Coarse > 60% (option F7 / ePM1 60%)	G4 / Coarse > 60% (option F7 / ePM1 60%)
Connected air duct diameter [mm]	200	200	200	200
Weight [kg]	72	72	72	72
Heat recovery efficiency [%]	88	82	88	82
Heat exchanger type	condensing	enthalpy	condensing	enthalpy
SEC class	A	A	A	A

\*Sound pressure level [dBA] at 3 m distance is specified at point 4 in average spherical free-field, for comparative use only

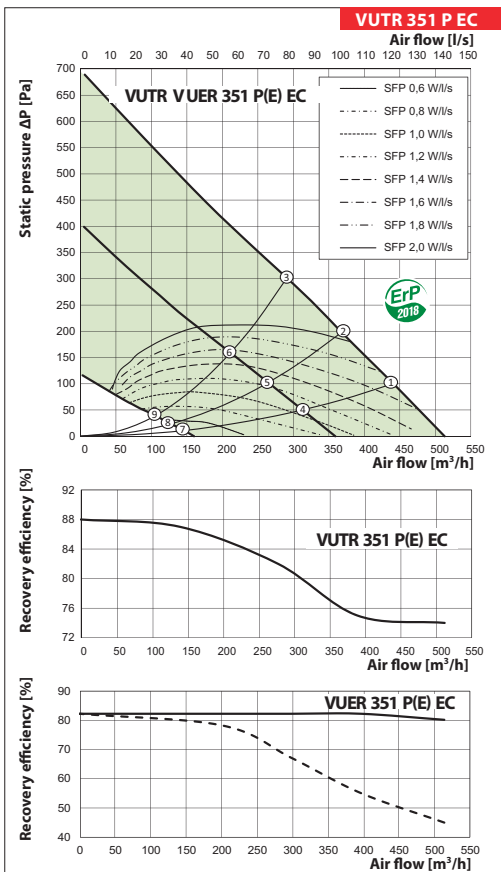

VUTR 351 P EC Sound-power level, A - weighted (p.1 on the diagram)	General dB(A)	Octave frequency band, Hz								LpA, 3m dB(A)	LpA, 1m dB(A)	
		63	125	250	500	1000	2000	4000	8000			
LwA to supply inlet	dB(A)	59	42	45	48	49	42	36	28	24	40	48
LwA to supply outlet	dB(A)	62	44	47	51	52	44	38	29	25	42	51
LwA to exhaust inlet	dB(A)	62	44	47	51	52	44	38	28	24	42	51
LwA to exhaust outlet	dB(A)	59	42	45	48	49	42	36	27	23	40	48
LwA to environment	dB(A)	59	42	50	49	46	47	45	36	31	39	48

VUTR 351 P EC Sound-power level, A - weighted (p.4 on the diagram)	General dB(A)	Octave frequency band, Hz								LpA, 3m dB(A)	LpA, 1m dB(A)	
		63	125	250	500	1000	2000	4000	8000			
LwA to supply inlet	dB(A)	49	33	36	40	38	31	26	21	23	29	39
LwA to supply outlet	dB(A)	51	35	38	42	40	33	27	22	24	30	40
LwA to exhaust inlet	dB(A)	50	35	38	42	40	33	25	21	23	30	39
LwA to exhaust outlet	dB(A)	53	37	40	44	42	35	26	22	24	32	41
LwA to environment	dB(A)	51	39	47	46	39	36	27	25	31	40	

# ROTARY HEAT RECOVERY UNITS

## Technical data

	VUTR 651 P EC A21	VUER 651 P EC A21	VUTR 651 PE EC A21	VUER 351 PE EC A21
Voltage [V / 50-60 Hz]	230	230	230	230
Max. unit power without electric heater [W]	377	377	377	377
Integrated electric heater power [W]	-	-	1400	1400
Max. unit power [W]	377	377	1777	1777
Max. unit current without electric heater [A]	2,58	2,58	2,58	2,58
Integrated electric heater current [A]	-	-	6,21	6,21
Max. unit current [A]	2,58	2,58	8,79	8,79
Max air flow [m <sup>3</sup> /h]	798	798	798	798
Sound pressure level at 3 m distance [dBA]	31	31	31	31
Transported air temperature [°C]	- 25...+40	- 25...+40	- 25...+40	- 25...+40
Case material	painted steel	painted steel	painted steel	painted steel
Insulation	40	40	40	40
Extract filter	G4 / Coarse > 60%	G4 / Coarse > 60%	G4 / Coarse > 60%	G4 / Coarse > 60%
Supply filters	G4 / Coarse > 60% (option F7 / ePM1 60%)	G4 / Coarse > 60% (option F7 / ePM1 60%)	G4 / Coarse > 60% (option F7 / ePM1 60%)	G4 / Coarse > 60% (option F7 / ePM1 60%)
Connected air duct diameter [mm]	250	250	250	250
Weight [kg]	103	103	104	104
Heat recovery efficiency [%]	85	84	85	84
Heat exchanger type	condensing	sorption	condensing	sorption
SEC class	A	A	A	A

\*Sound pressure level at 3 m distance is specified at point 4 [dBA]

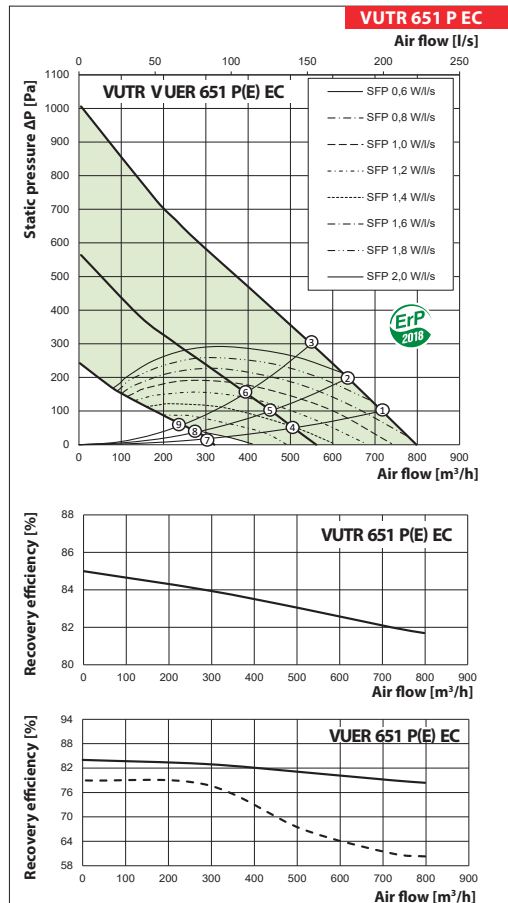

VUTR 651 P EC Sound-power level, A - weighted (p.1 on the diagram)	General dB(A)	Octave frequency band, Hz								LpA, 3m dB(A)	LpA, 1m dB(A)
		63	125	250	500	1000	2000	4000	8000		
LwA to supply inlet	67	45	48	51	57	57	50	48	43	47	56
LwA to supply outlet	71	47	50	54	60	60	53	51	45	51	60
LwA to exhaust inlet	63	44	47	51	50	46	43	36	28	43	52
LwA to exhaust outlet	60	42	45	48	48	44	41	34	27	40	49
LwA to environment	61	38	46	45	51	50	50	43	38	41	50

VUTR 651 P EC Sound-power level, A - weighted (p.4 on the diagram)	General dB(A)	Octave frequency band, Hz								LpA, 3m dB(A)	LpA, 1m dB(A)
		63	125	250	500	1000	2000	4000	8000		
LwA to supply inlet	58	42	45	48	48	48	41	35	28	38	47
LwA to supply outlet	60	44	47	51	50	50	43	37	29	40	49
LwA to exhaust inlet	54	44	47	51	41	36	32	23	23	34	43
LwA to exhaust outlet	57	46	49	54	43	38	34	24	24	37	46
LwA to environment	51	38	46	45	40	39	40	28	25	31	40

**Accessories for air handling units**

Type	Filter G4	Supply filter F7	Control panel	Control panel	WiFi Control panel	Internal humidity sensor	Internal CO <sub>2</sub> sensor
VUTR 251 P EC A21	SF 266x222x48 Coarse 90% G4	SF 266x222x48 ePM1 60% F7	A25	A22	A22 Wi-Fi	HV-2	CO2-3
VUTR 251 PE EC A21							
VUTR 351 P EC A21	SF 302x256x48 Coarse 90% G4	SF 302x256x48 ePM1 60% F7					
VUTR 351 PE EC A21							
VUTR 651 P EC A21	SF 377x330x48 Coarse 90% G4	SF 377x330x48 ePM1 60% F7					
VUTR 651 PE EC A21							

Type	External CO <sub>2</sub> sensor with indication	External humidity sensor	Silencer	Air damper	Electric actuator
VUTR 251 P EC A21	CO2-1	HR-S	SR 160	KRV 160	TF 230
VUTR 251 PE EC A21					
VUTR 351 P EC A21			SR 200	KRV 200	
VUTR 351 PE EC A21					
VUTR 651 P EC A21			SR 250	KRV 250	
VUTR 651 PE EC A21					

Application options

Ceiling connector with a disc valve



Manifold

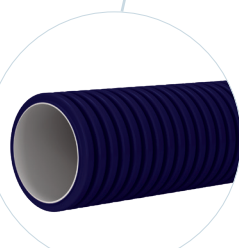
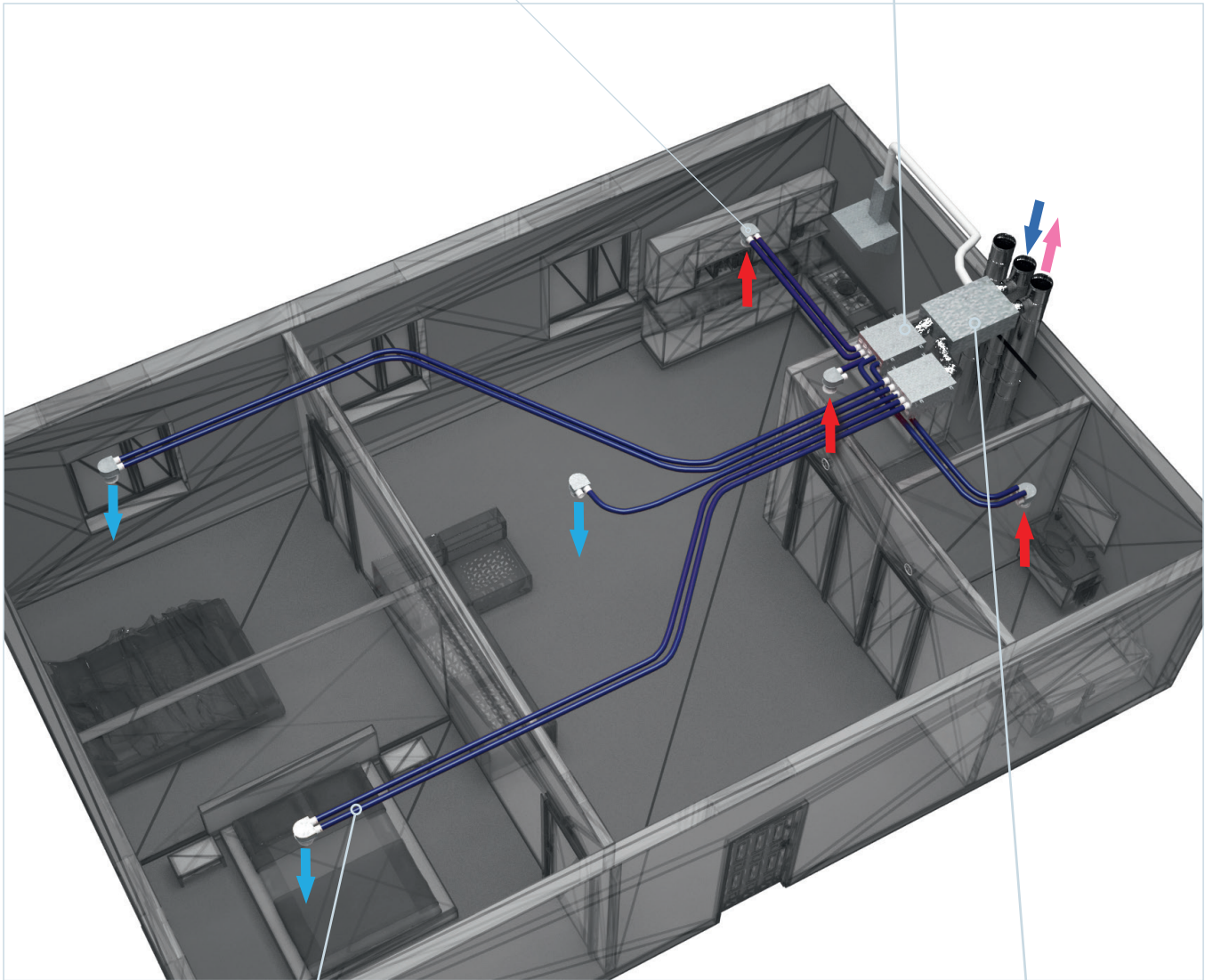
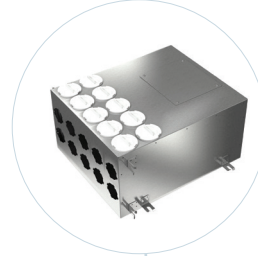

FlexiVent air duct

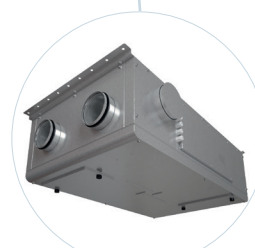

Air handling unit



Series  
**VENTS VUT PB EC**

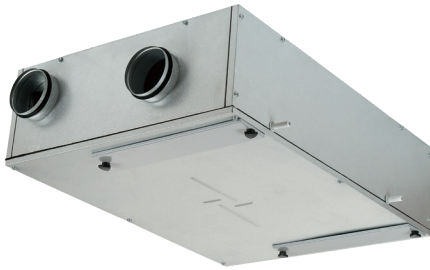

Air handling units in heat- and sound-insulated casing.  
Air flow up to **410 m<sup>3</sup>/h**.  
Heat recovery efficiency up to **94 %**

**Description**

The VUT PB EC air handling units are the fully-featured ventilation units that ensure air filtration, fresh air supply and stale air extract.

**Casing**

Made of galvanised steel, internally filled with a 40 mm heat- and sound-insulating layer of mineral wool.

**Filter**

Built-in panel filters with filtration class F7 provide efficient supply air filtration.  
Panel filters with filtration class G4 provide extract air

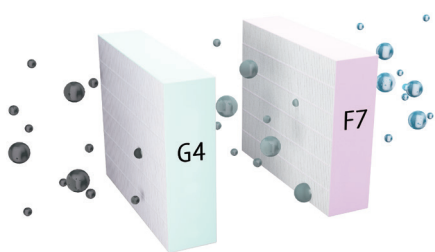

**Fans**

High-efficient electronically-commutated motors with an external rotor and backward curved blades.

**Heat exchanger**

The units are equipped with a high-efficient counter-flow polystyrene heat exchanger. In the cold season the extract air heat is captured and transferred to the supply air stream which reduces the ventilation-generated heat losses.

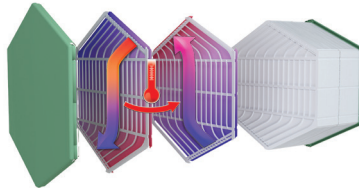

**Frost protection**

To protect the heat exchanger from freezing in the cold season, the unit has a Frost Protection mode based on the temperature sensor readings. The Frost Protection mode is activated at an exhaust air temperature of +3 °C. After temperature increase the unit returns to the previous operation mode. In case of freezing danger, the supply fan is turned off in VUT PB EC A14 units. Three modes of frost protection are available in VUT PB EC A21 models:

- gradual reduction of the supply fan speed
- with the bypass
- with the electric preheater (available as an accessory).

**Bypass**

The units are equipped with a 100 % bypass which can be opened for summer cooling.

**Control and automation**

The **VUT PB EC A21** units are equipped with an integrated automation system.

The A21 controller enables integration of the unit into the **Smart Home System** or **BMS (Building Management Systems)**.

To control the unit via Wi-Fi, download the VENTS Home mobile app.



Google play



Download on the App Store



The **VUT PB EC A14** units are equipped with an integrated automation system and a wall-mounted control panel A14 with LED indication.





**Mounting**

The units are designed for ceiling or wall mounting (horizontal spigot orientation) in a position allowing condensate collection and removal into a special drain pan. The access for filter maintenance and replacement is available from the bottom panel.

**Designation key**

Series	Rated air flow [m <sup>3</sup> /h]	Installation type	Bypass	Motor type	Service side	Automation
<b>VUT</b>	350	<b>P:</b> suspended installation	<b>B:</b> bypass	<b>EC:</b> synchronous electronically commutated motor	<b>L:</b> left <b>R:</b> right	<b>A14</b> <b>A21</b>

**Control and automation**

Functions	A21	A14
Wired remote control panel	Option (A22) 	A14 
Control via a wired remote LCD control panel	Option (A25) 	-
Wireless remote control panel	Option (A22 Wi-Fi) 	-
BMS	RS-485 Wi-Fi Ethernet MODBUS (RTU, TCP)	-
Vents Cloud Server service	+	-
Control via Wi-Fi using a mobile application	+	-
Frost protection	+	+
Bypass	Auto + manual	Manual
Week-scheduled operation	+	-
Filter replacement indication	According to filter timer	According to filter timer
	According to filter clogging differential pressure switch readings	
Alarm indication	+	+
Speed selection	+	+
Timers	+	-
RH% sensor	Option	Option
CO <sub>2</sub> sensor	Option	Option
VOC sensor	Option	Option
PM2.5 sensor	Option	Option
Boost mode	+	-
Fireplace mode	+	-
Preheater connection	Option	-
Reheater connection	Option	-
Fire alarm sensor	Option	Option
Minimum supply air temperature control	+	-

**Overall dimensions**

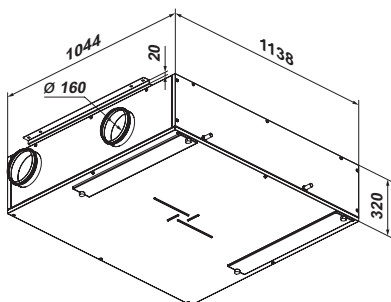

**VUT 350 PB EC**

## COUNTERFLOW HEAT RECOVERY UNITS IN METAL CASING

### Technical data

	VUT 350 PB EC
Unit voltage [V/50 (60) Hz]	1~230
Maximum unit power [W]	170
Maximum unit current [A]	1.3
Maximum air flow [m <sup>3</sup> /h]	410
Sound pressure level at 3 m distance [dBA]	34
Transported air temperature [°C]	-25...+40
Casing material	Aluzinc steel
Insulation	40 mm mineral wool
Filter (extract/supply)	G4/F7
Connected air duct diameter [mm]	Ø 160
Weight [kg]	70
Heat recovery efficiency [%]	80-91
Heat exchanger type	Counter-flow
SEC class	A
Heat exchanger material	Polystyrene

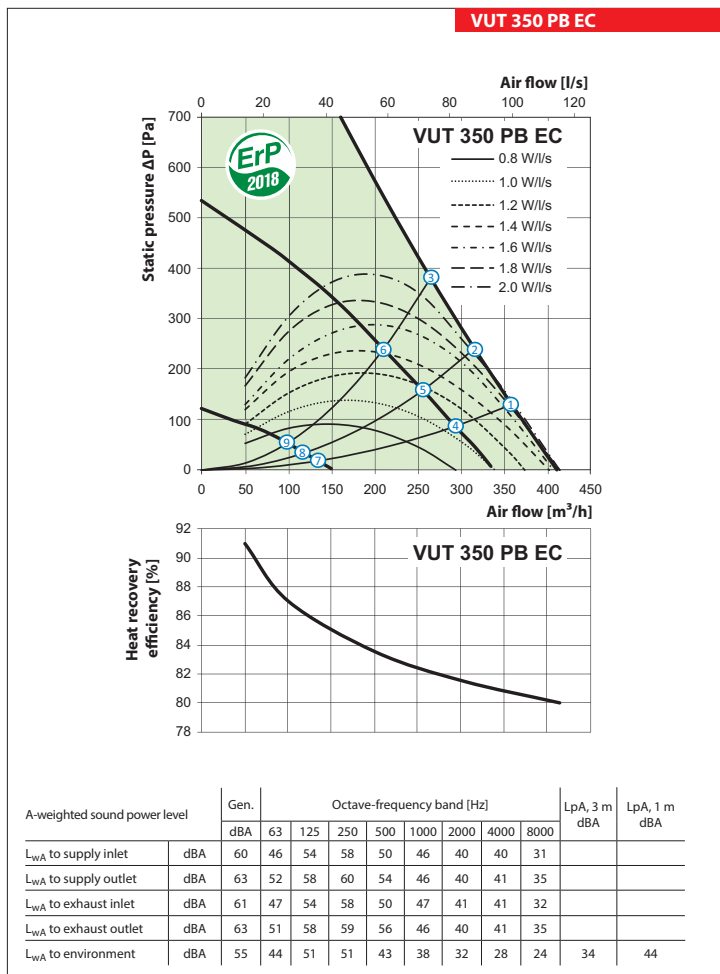

Point	Power [W]	Sound pressure level at 3 m (1 m) distance [dBA]
	VUT 350 PB EC	VUT 350 PB EC
1	169	34 (44)
2	169	34 (44)
3	169	33 (43)
4	87	28 (38)
5	86	28 (38)
6	84	27 (37)
7	20	22 (32)
8	19	22 (32)
9	19	21 (31)

**Accessories for air handling units**

Model	G4 panel filter	F7 panel filter	Control panel	Control panel with Wi-Fi	LCD control panel	Indoor humidity sensor	Outdoor CO <sub>2</sub> sensor with indication	Outdoor CO <sub>2</sub> sensor
	VUT 350 PB EC A14	SF 603x253x48 G4	SF 603x253x48 F7	-	-	-	HV2	CO2-1
VUT 350 PB EC A21			A22	A22 WiFi	A25			

Model	Outdoor humidity sensor	Electric heater for preheating	Electric re-heater	Hydraulic U-trap	Air damper	Electric actuator
	VUT 350 PB EC A14		-	-		
VUT 350 PB EC A21	HR-S	NKP 160 A21 V.2	NKD 160 A21 V.2	SH-32	KRV 160	LF230

**Application options**

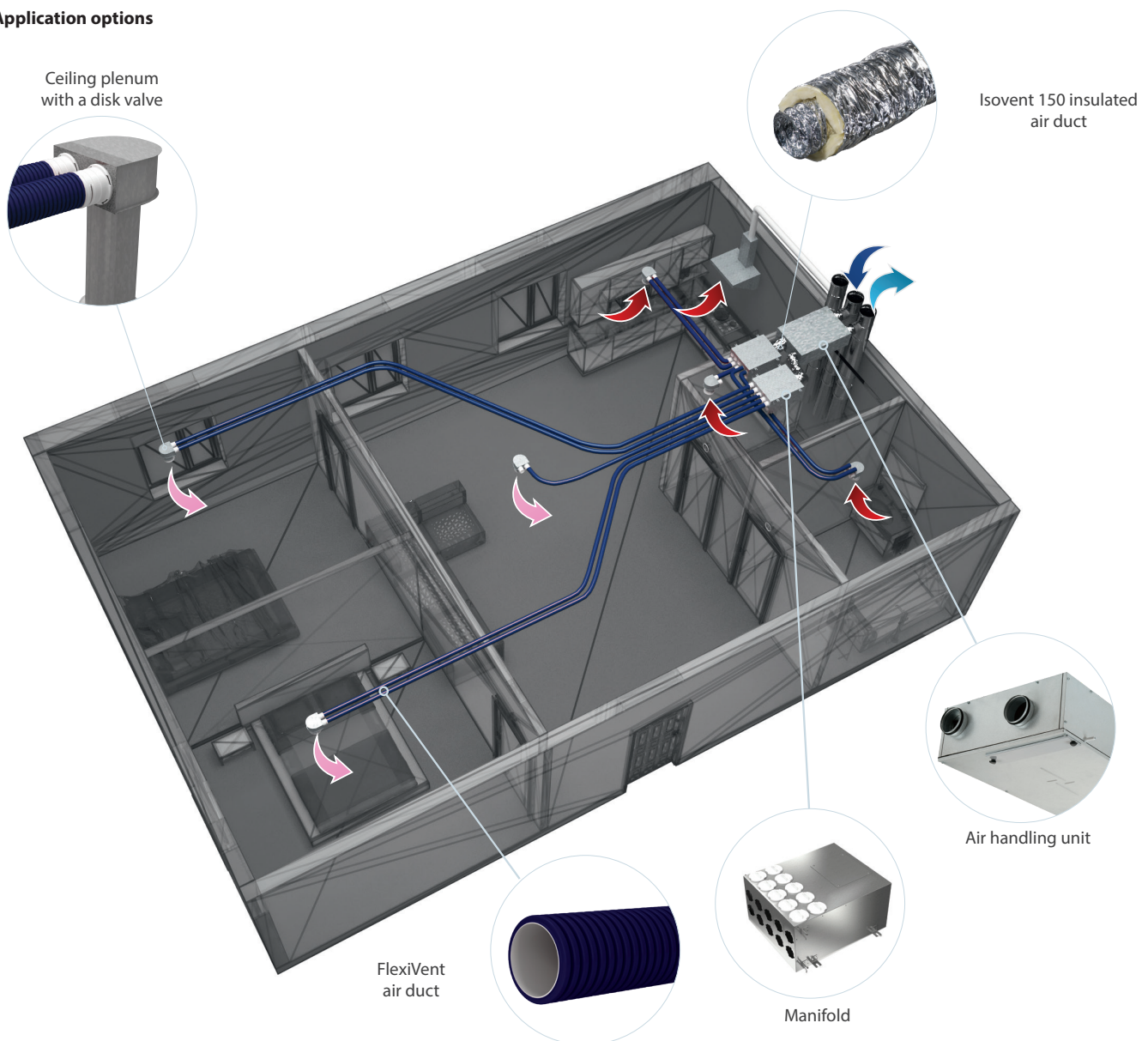

Series  
**VENTS VUT/VUE VB EC**



Air handling units in heat- and sound-insulated casing.  
Air flow up to **690 m<sup>3</sup>/h**.  
Heat recovery efficiency up to **93 %**

**Description**

The air-handling units are the fully featured ventilation units with heat recovery for air filtration, fresh air supply and stale air extraction.

**Casing**

Made of high-quality polymer coated steel, internally filled with mineral wool layer for heat and sound insulation.

**Filter**

Supply and exhaust air flows are purified through panel filters with filtering class G4 and F7, respectively. Filters with G4 filtering class are used for supply and exhaust air purification in the **VUT/VUE 250 VB EC** units. F7 filter is available as an option for supply air filtration.

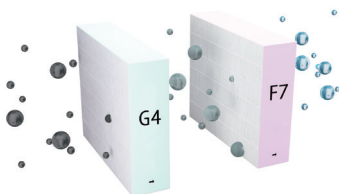

**Fans**

The units are equipped with high-efficient EC motors with an external rotor and a centrifugal impeller with backward curved blades.

**Heat exchanger**

The **VUT V(B) EC** units are equipped with a counter-flow polystyrene heat exchanger.

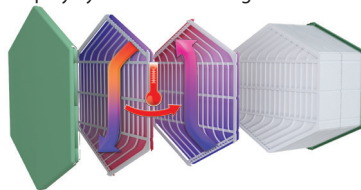

The **VUE V(B) EC** units are equipped with a counter-flow enthalpy heat exchanger.

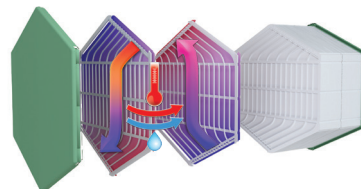

**Bypass**

The **VUT/VUE VB EC** units are equipped with a bypass for summer cooling.

**Automation**

The **VUT/VUE V(B) EC A21** units are equipped with a built-in automation system. The A21 controller allows integrating the unit into the Smart Home system or BMS (Building Management Systems). To control the unit via Wi-Fi, download the VENTS Home mobile app.

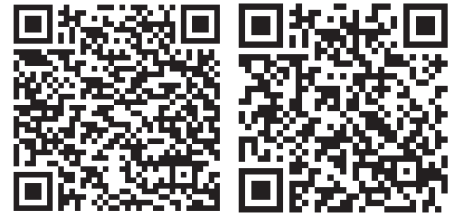

Google play

Download on the App Store



The **VUT/VUE V(B) EC A14** units have an integrated control system with a wall-mounted control panel A14 with a LED indication.

**Frost protection**

In the **VUT/VUE 160/350/550 VB EC A21** units it is possible to connect a preheater to protect the unit from freezing.

The **VUT 250 VBE EC A21** unit is equipped with a built-in preheater for frost protection.

**Mounting**

The units are designed for wall or floor mounting. Access for maintenance of units and filters is possible from the right and left sides.

**Overall dimensions**

Model	Dimensions [mm]			
	Ø D	B	H	L
VUT/VUE 160 V EC	125	330	550	600
VUT/VUE 160 V1 EC	125	370	590	640
VUT/VUE 160 VB EC	125	330	580	600
VUT/VUE 160 V1B EC	125	370	620	640
VUT/VUE 250 VB EC L/R	160	560	970	560
VUT/VUE 350 VB EC	160	583	675	730
VUT/VUE 350 V1B EC	160	470	675	730
VUT/VUE 550 VB EC	200	720	675	823

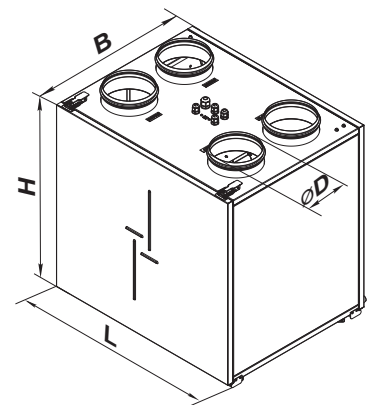





**Designation key**

Series	Rated air flow [m <sup>3</sup> /h]	Installation features	Casing design	Bypass	Motor type	Service side*	Control
<b>VUT:</b> ventilation with heat recovery <b>VUE:</b> ventilation with energy recovery	160, 250, 350, 550	<b>V:</b> vertical	- by default <b>1:</b> casing modification	_ : without bypass <b>B:</b> with bypass	<b>EC:</b> synchronous electronically commutated motor	<b>L:</b> left <b>R:</b> right	<b>A14</b> <b>A21</b>

\* Only for VUT 250 VB EC L/R

**Control and automation**

Functions	A21	A14
Wired remote control panel	Option (A22) 	A14 
Control via a wired remote LCD control panel	Option (A25) 	-
Wireless remote control panel	Option (A22 Wi-Fi) 	-
BMS	RS-485 Wi-Fi Ethernet MODBUS (RTU, TCP)	-
Vents Cloud Server service	+	-
Control via Wi-Fi using a mobile application	+	-
Frost protection	+	+
Bypass	Auto + manual	Manual
Week-scheduled operation	+	-
Filter replacement indication	By the filter timer	By the filter timer
	According to filter clogging differential pressure switch readings (only for VUT/VUE 550 VB EC A21)	
Alarm indication	+	+
Speed selection	+	+
Timer	+	-
RH% sensor	Option	Option
CO <sub>2</sub> sensor	Option	Option
VOC sensor	Option	Option
PM2.5 sensor	Option	Option
Boost mode	+	-
Fireplace mode	+	-
Preheater connection	Option (built-in preheater in VUT 250 VBE EC units)	-
Reheater connection	Option	-
Fire alarm sensor	Option	Option
Minimum supply air temperature control	+	-

**Unit design**

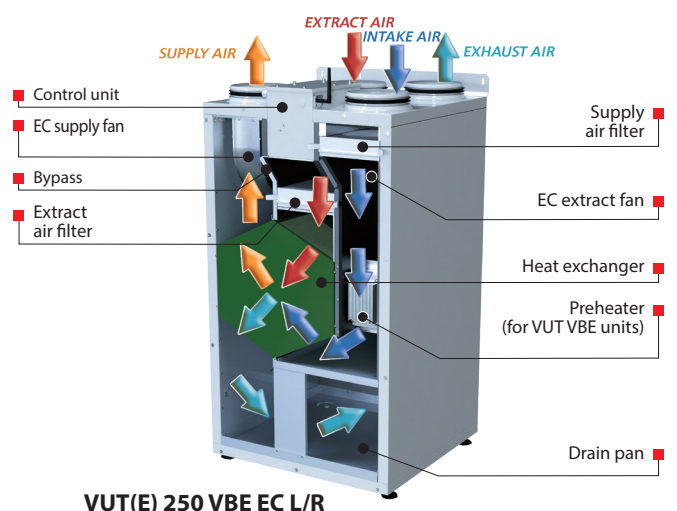
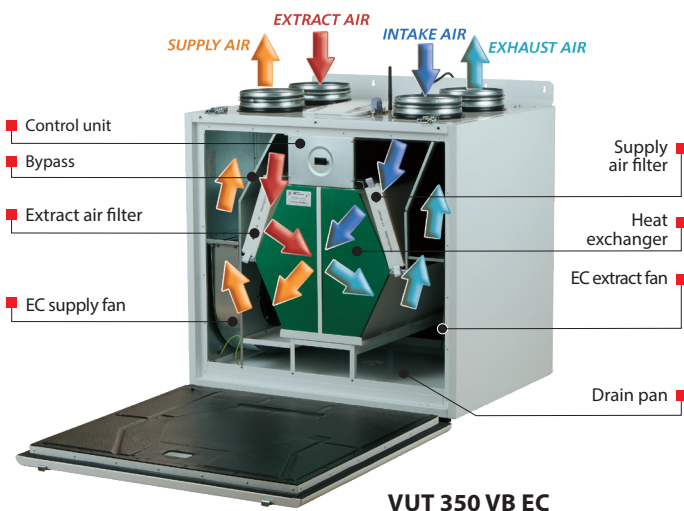

# COUNTERFLOW HEAT RECOVERY UNITS IN METAL CASING

## Technical data

	VUT 160 VB EC	VUE 160 VB EC	VUT 160 V1B EC	VUE 160 V1B EC
Unit voltage [V/50 (60) Hz]	1~230			
Maximum power [W]	57			
Maximum current [A]	0.5			
Maximum air flow [m³/h]	200			
Sound pressure level at 3 m distance [dBA]	24		22	
Transported air temperature [°C]	-25...+40			
Casing material	painted steel			
Insulation	20 mm mineral wool		40 mm mineral wool	
Extract filter	G4			
Supply filter	F7 (G4 – option)			
Connected air duct diameter [mm]	Ø125			
Weight [kg]	36		44	
Heat recovery efficiency [%]	85–93	76–92	85–93	76–92
Heat exchanger type	counter-flow			
Heat exchanger material	polystyrene	enthalpy membrane	polystyrene	enthalpy membrane
Energy efficiency class for A14, A21	A+	A	A+	A

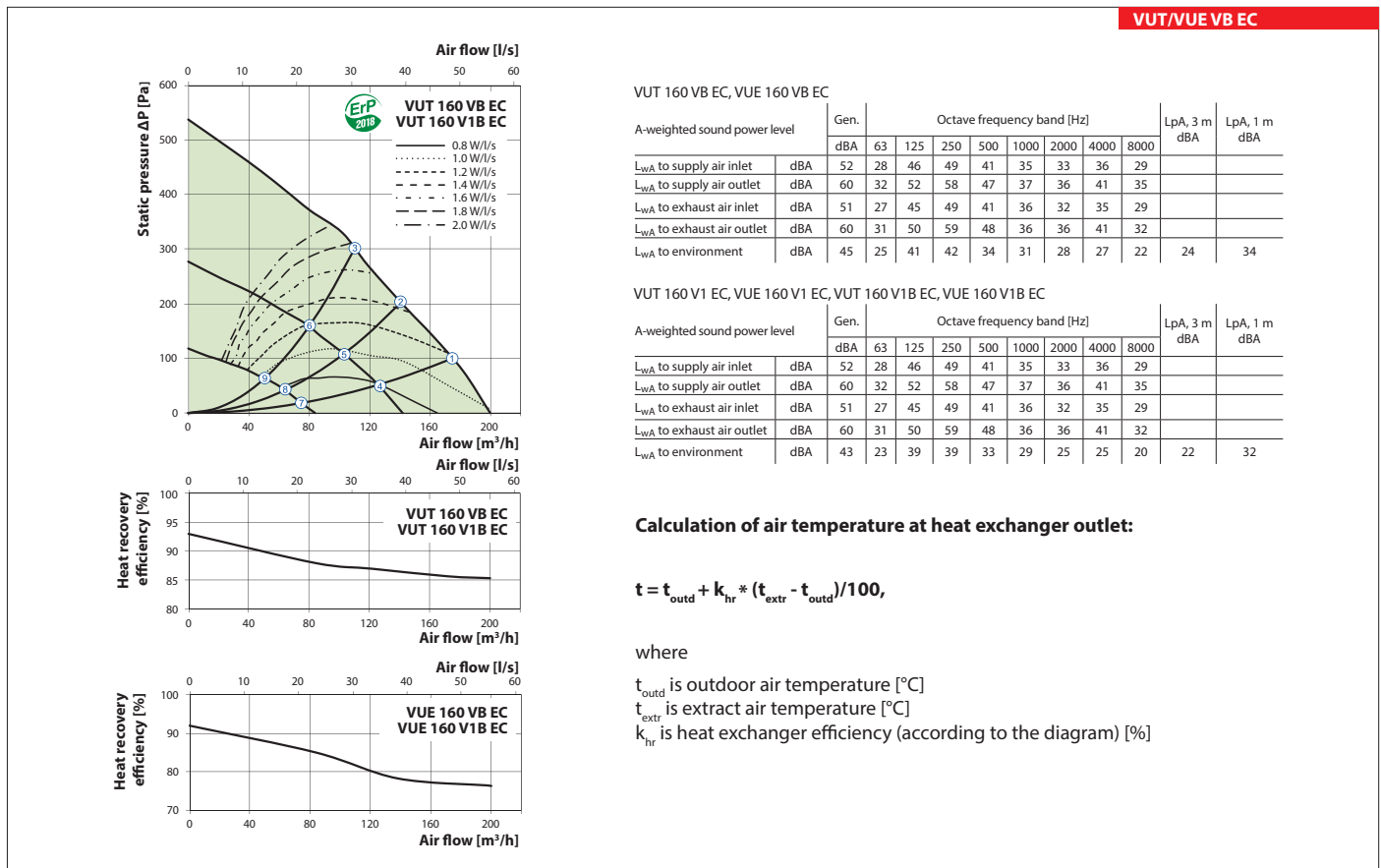

VUT 160 VB EC, VUE 160 VB EC

A-weighted sound power level

	Gen. dBA	Octave frequency band [Hz]								LpA, 3 m dBA	LpA, 1 m dBA
		63	125	250	500	1000	2000	4000	8000		
L <sub>WA</sub> to supply air inlet	52	28	46	49	41	35	33	36	29		
L <sub>WA</sub> to supply air outlet	60	32	52	58	47	37	36	41	35		
L <sub>WA</sub> to exhaust air inlet	51	27	45	49	41	36	32	35	29		
L <sub>WA</sub> to exhaust air outlet	60	31	50	59	48	36	36	41	32		
L <sub>WA</sub> to environment	45	25	41	42	34	31	28	27	22	24	34

VUT 160 V1 EC, VUE 160 V1 EC, VUT 160 V1B EC, VUE 160 V1B EC

A-weighted sound power level

	Gen. dBA	Octave frequency band [Hz]								LpA, 3 m dBA	LpA, 1 m dBA
		63	125	250	500	1000	2000	4000	8000		
L <sub>WA</sub> to supply air inlet	52	28	46	49	41	35	33	36	29		
L <sub>WA</sub> to supply air outlet	60	32	52	58	47	37	36	41	35		
L <sub>WA</sub> to exhaust air inlet	51	27	45	49	41	36	32	35	29		
L <sub>WA</sub> to exhaust air outlet	60	31	50	59	48	36	36	41	32		
L <sub>WA</sub> to environment	43	23	39	39	33	29	25	25	20	22	32

### Calculation of air temperature at heat exchanger outlet:

$$t = t_{\text{outd}} + k_{\text{hr}} * (t_{\text{extr}} - t_{\text{outd}}) / 100,$$

where

$t_{\text{outd}}$  is outdoor air temperature [°C]

$t_{\text{extr}}$  is extract air temperature [°C]

$k_{\text{hr}}$  is heat exchanger efficiency (according to the diagram) [%]

**Technical data**

	VUT 250 VB EC L/R	VUE 250 VB EC L/R	VUT 250 VBE EC L/R	VUE 250 VBE EC L/R
Unit voltage [V/50 (60) Hz]	1~230			
Maximum power [W]	180			
Maximum current [A]	1.37			
Electric heater power [W]	-	-	1400	
Electric heater current [A]	-	-	6.09	
Maximum unit power with an electric heater [W]	180	-	1580	
Maximum unit current (with an electric heater) [A]	1.37	-	7.46	
Maximum air flow [m³/h]	390			
Sound pressure level at 3 m distance [dBA]	35			
Transported air temperature [°C]	-25...+40			
Casing material	painted steel			
Insulation	30 mm mineral wool			
Extract filter	G4			
Supply filter	G4 (F7 – option)			
Connected air duct diameter [mm]	Ø160			
Weight [kg]	66			
Heat recovery efficiency [%]	88–95	78–90	88–95	78–90
Heat exchanger type	counter-flow			
Heat exchanger material	polystyrene	enthalpy membrane	polystyrene	enthalpy membrane
Energy efficiency class for A14, A21	A+	A	A+	A

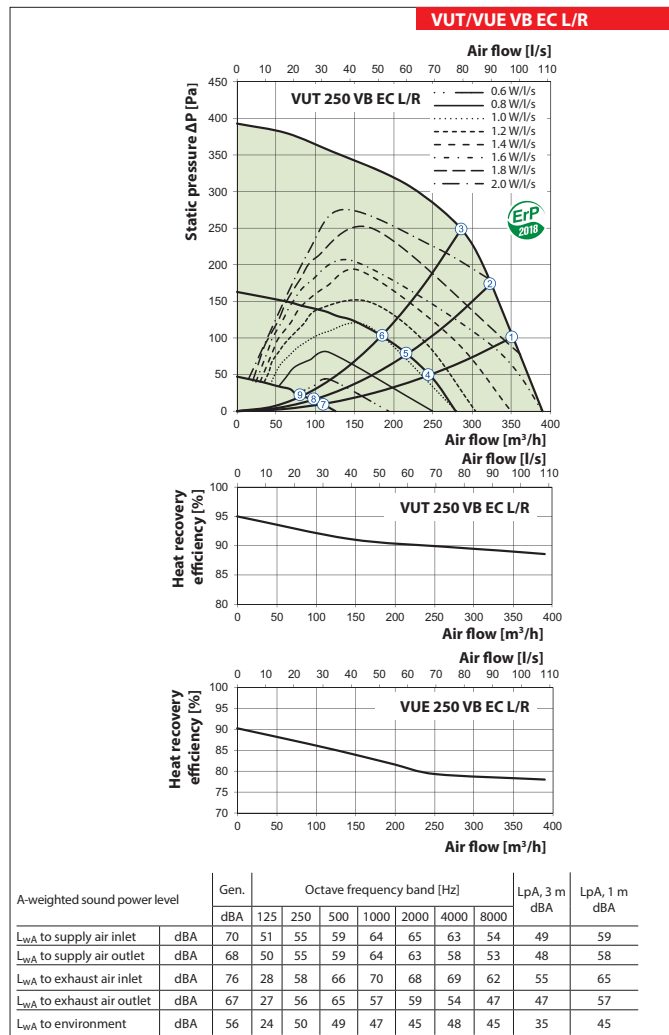

# COUNTERFLOW HEAT RECOVERY UNITS IN METAL CASING

## Technical data

	VUT 350 V1B EC	VUE 350 V1B EC	VUT 350 VB EC	VUE 350 VB EC
Unit voltage [V/50 (60) Hz]	1~230		1~230	
Maximum power [W]	169		178	
Maximum current [A]	1.3		1.4	
Maximum air flow [m³/h]	420		450	
Sound pressure level at 3 m distance [dBA]	28		28	
Transported air temperature [°C]	-25...+40		-25...+40	
Casing material	painted steel		painted steel	
Insulation	40 mm mineral wool		40 mm mineral wool	
Extract filter	G4		G4	
Supply filter	F7 (G4 – option)		F7 (G4 – option)	
Connected air duct diameter [mm]	Ø160		Ø160	
Weight [kg]	57		64	
Heat recovery efficiency [%]	85–92	74–91	85–92	73–91
Heat exchanger type	counter-flow		counter-flow	
Heat exchanger material	polystyrene	enthalpy membrane	polystyrene	enthalpy membrane
Energy efficiency class for A14, A21	A+	A	A+	A

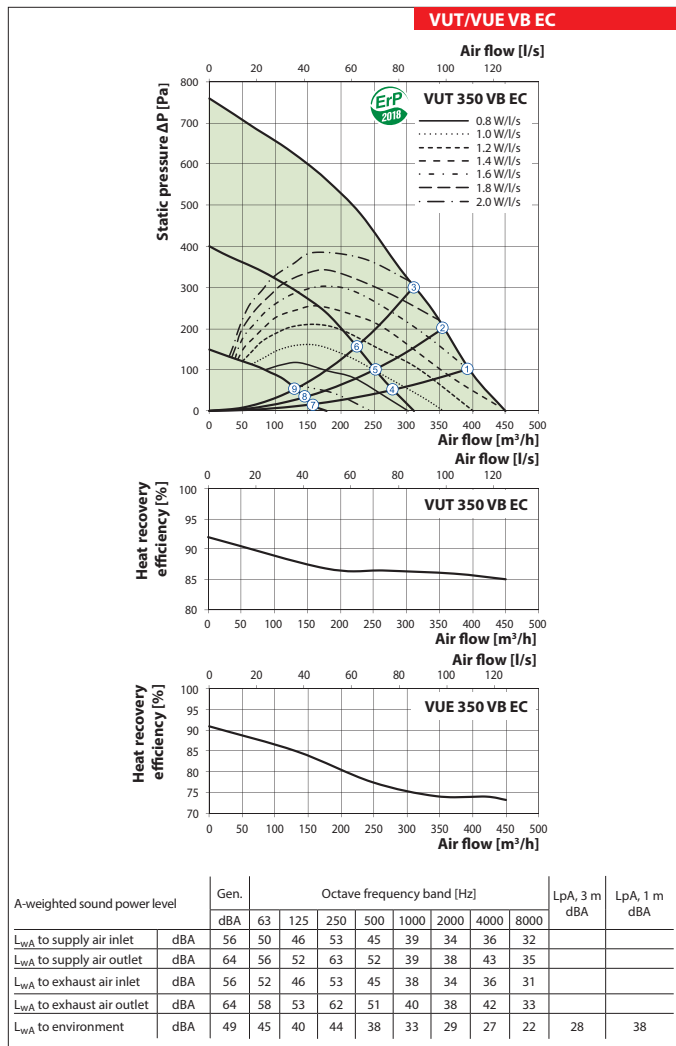
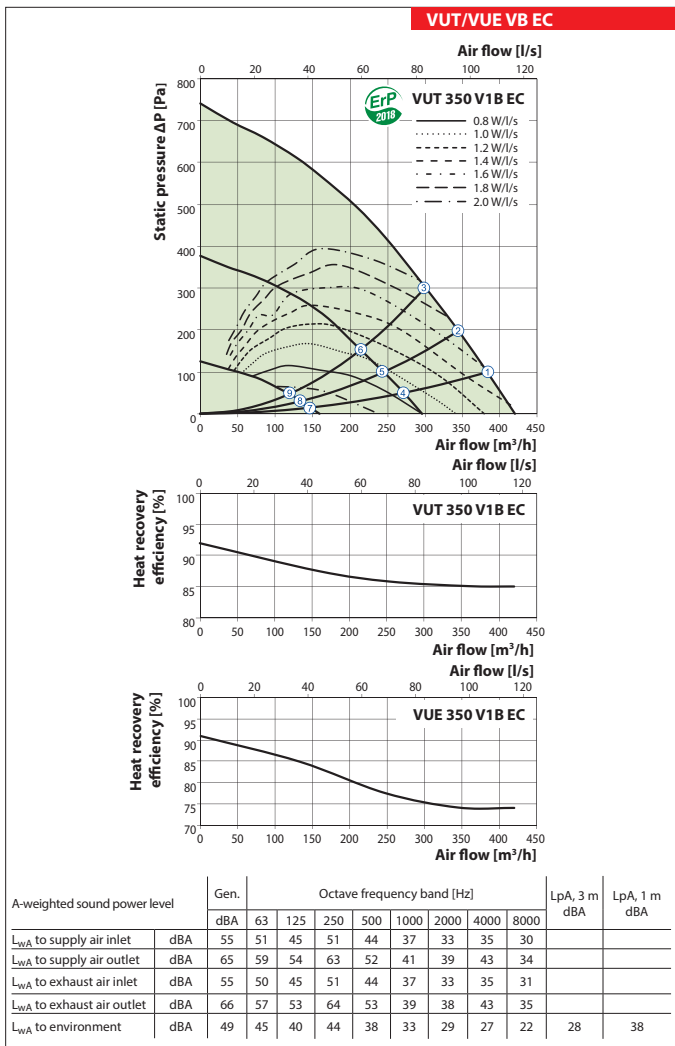

**Technical data**

	VUT 550 VB EC	VUE 550 VB EC
Unit voltage [V/50 (60) Hz]	1~230	
Maximum power [W]	350	
Maximum current [A]	2.4	
Maximum air flow [m³/h]	692	
Sound pressure level at 3 m distance [dBA]	38	
Transported air temperature [°C]	-25...+40	
Casing material	painted steel	
Insulation	40 mm mineral wool	
Extract filter	G4	
Supply filter	F7 (G4 – option)	
Connected air duct diameter [mm]	Ø200	
Weight [kg]	82	
Heat recovery efficiency [%]	84–92	73–91
Heat exchanger type	counter-flow	
Heat exchanger material	polystyrene	enthalpy membrane
Energy efficiency class for A14, A21	A+	A

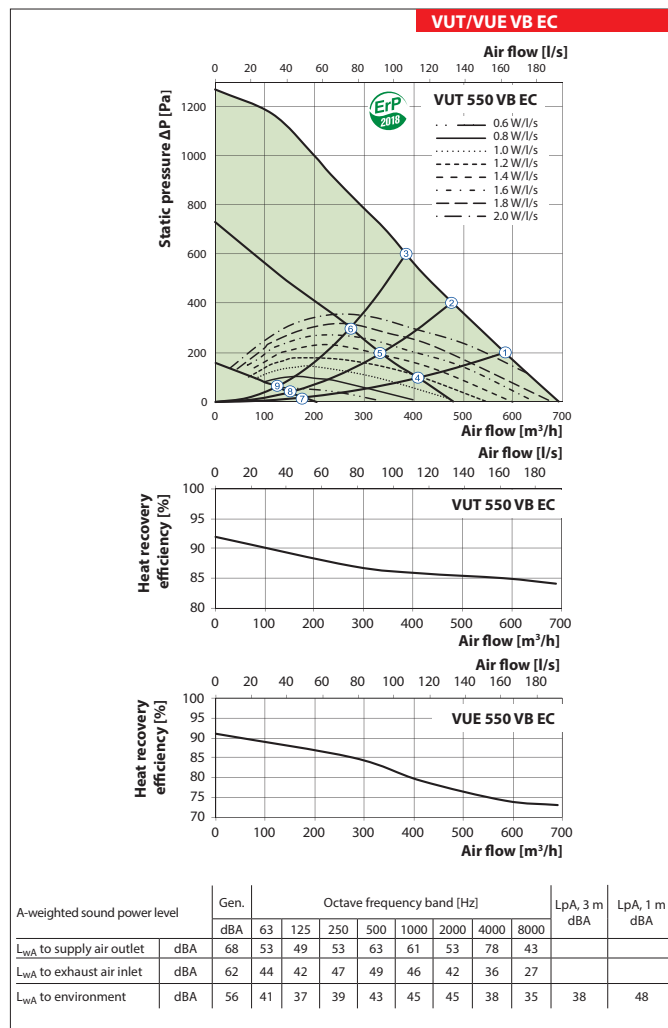

## COUNTERFLOW HEAT RECOVERY UNITS IN METAL CASING

### Technical data

Point	Power [W]				
	VUT 160 VB EC VUT 160 V1B EC VUE 160 VB EC VUE 160 V1B EC	VUT 250 VB EC L/R VUE 250 VB EC L/R	VUT 350 V1B EC VUE 350 V1B EC	VUT 350 VB EC VUE 350 VB EC	VUT 550 VB EC VUE 550 VB EC
1	57	180	168	177	345
2	56	179	166	175	349
3	54	168	162	170	349
4	28	63	65	71	131
5	27	57	64	71	131
6	26	52	62	69	131
7	14	15	18	21	22
8	13	15	17	21	22
9	13	14	17	21	22

Point	Sound pressure level at 3 m (1 m) distance, dB(A)				
	VUT 160 VB EC VUT 160 V1B EC VUE 160 VB EC VUE 160 V1B EC	VUT 250 VB EC L/R VUE 250 VB EC L/R	VUT 350 V1B EC VUE 350 V1B EC	VUT 350 VB EC VUE 350 VB EC	VUT 550 VB EC VUE 550 VB EC
1	24 (34)	35 (45)	28 (38)	28 (38)	38 (48)
2	23 (33)	35 (45)	27 (37)	27 (37)	36 (45)
3	23 (33)	35 (45)	27 (37)	27 (37)	36 (45)
4	20 (30)	24 (34)	23 (33)	23 (33)	27 (37)
5	20 (30)	24 (34)	22 (32)	22 (32)	27 (37)
6	20 (30)	23 (33)	22 (32)	22 (32)	27 (37)
7	13 (23)	18 (27)	15 (25)	15 (25)	17 (26)
8	13 (23)	17 (27)	14 (24)	14 (24)	17 (27)
9	13 (23)	17 (27)	14 (24)	14 (24)	17 (27)

### Application options

Ventilation hood



Ceiling connector with a disk valve

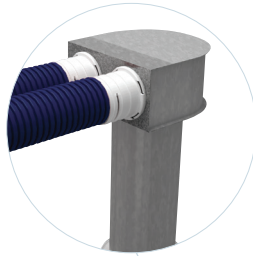

Isovent 150 insulated air duct

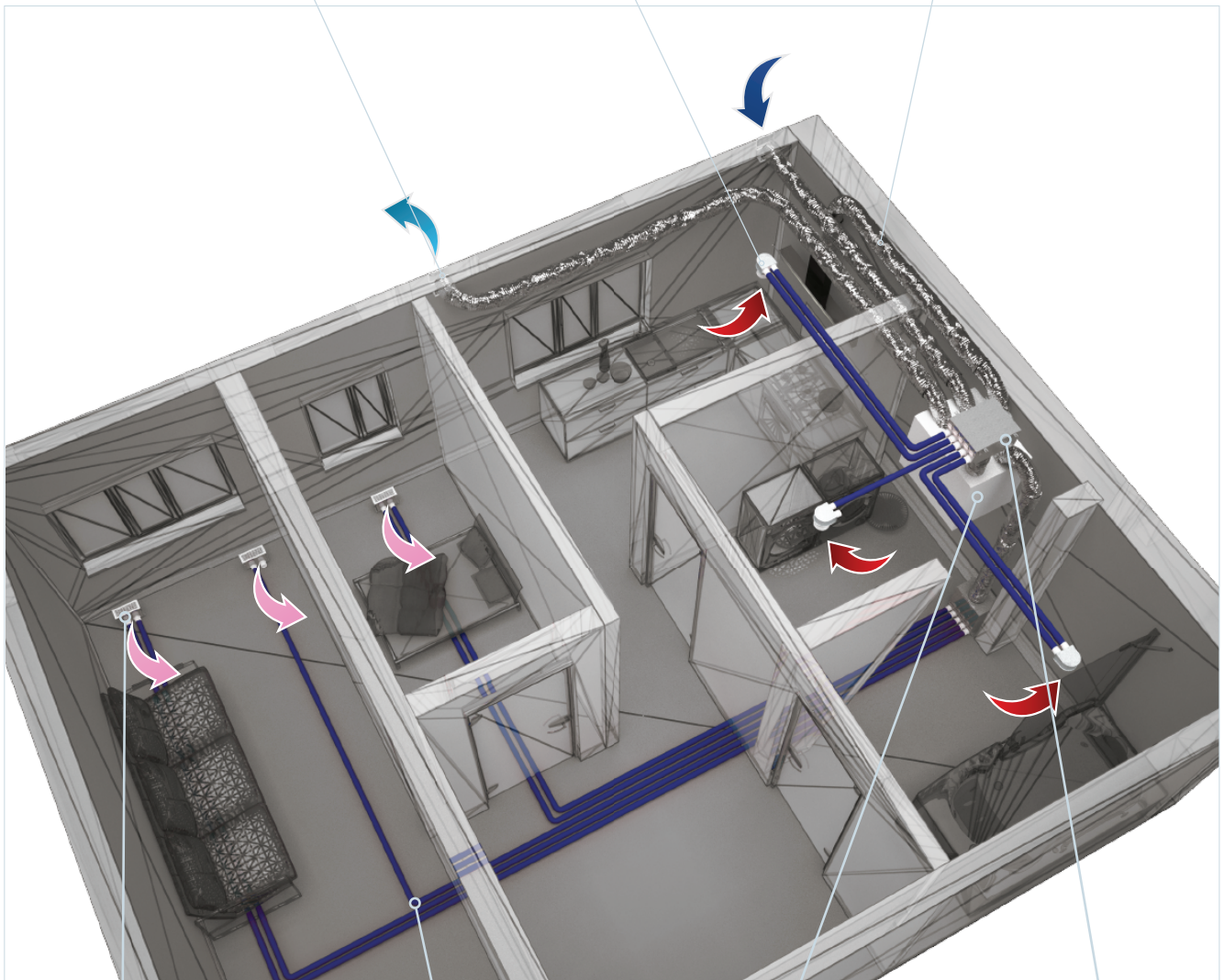

Floor connector with a grille

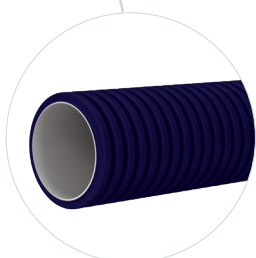

FlexiVent air duct





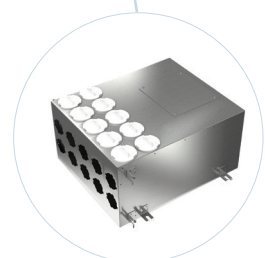





Air handling unit



Manifold

## COUNTERFLOW HEAT RECOVERY UNITS IN METAL CASING

### Accessories for air handling units

Model	G4 panel supply filter	G4 panel exhaust filter	F7 panel supply filter	LCD control panel	Control panel	Control panel with Wi-Fi	Indoor humidity sensor	CO <sub>2</sub> sensor with indication	CO <sub>2</sub> sensor
									
VUT 160 VB EC A21	SF 285x195x10 G4		SF 285x195x10 F7	A25	A22	A22 Wi-Fi	HV2	CO2-1	CO2-2
VUT 160 VB EC A14				-	-	-			
VUE 160 VB EC A21				A25	A22	A22 Wi-Fi			
VUE 160 VB EC A14				-	-	-			
VUT 160 V1B EC A21				A25	A22	A22 Wi-Fi			
VUT 160 V1B EC A14				-	-	-			
VUE 160 V1B EC A21				A25	A22	A22 Wi-Fi			
VUE 160 V1B EC A14				-	-	-			
VUT 250 VB EC A21	SF 340x170x48 G4	SF 500x170x48 G4	SF 340x170x48 F7	A25	A22	A22 Wi-Fi			
VUT 250 VBE EC A21				A25	A22	A22 Wi-Fi			
VUT 250 VB EC A14				-	-	-			
VUE 250 VB EC A21				A25	A22	A22 Wi-Fi			
VUE 250 VBE EC A21				A25	A22	A22 Wi-Fi			
VUE 250 VB EC A14				-	-	-			
VUT 350 V1B EC A21	SF 384x196x40 G4	SF 384x196x40 F7	SF 384x196x40 F7	A25	A22	A22 Wi-Fi			
VUT 350 V1B EC A14				-	-	-			
VUT 350 V1B EC A21				A25	A22	A22 Wi-Fi			
VUE 350 V1B EC A14				-	-	-			
VUT 350 VB EC A21	SF 500x196x40 G4	SF 500x196x40 F7	SF 500x196x40 F7	A25	A22	A22 Wi-Fi			
VUT 350 VB EC A14				-	-	-			
VUE 350 VB EC A21				A25	A22	A22 Wi-Fi			
VUE 350 VB EC A14				-	-	-			
VUT 550 VB EC A21	SF 630x198x40 G4	SF 630x198x40 F7	SF 630x198x40 F7	A25	A22	A22 Wi-Fi			
VUT 550 VB EC A14				-	-	-			
VUE 550 VB EC A21				A25	A22	A22 Wi-Fi			
VUE 550 VB EC A14				-	-	-			

Model	Humidity sensor	Electric preheater	Electric reheater	Hydraulic U-trap	Air damper	Electric actuator
VUT 160 VB EC A21	HR-S	NKP-125 A21 V.2	NKD-125 A21 V.2	SH-32	KRV 125	LF230
VUT 160 VB EC A14		-	-			
VUE 160 VB EC A21		NKP-125 A21 V.2	NKD-125 A21 V.2	-		
VUE 160 VB EC A14		-	-			
VUT 160 V1B EC A21		NKP-125 A21 V.2	NKD-125 A21 V.2	SH-32		
VUT 160 V1B EC A14		-	-			
VUE 160 V1B EC A21		NKP-125 A21 V.2	NKD-125 A21 V.2	-		
VUE 160 V1B EC A14		-	-			
VUT 250 VB EC A21		-	NKD-160 A21 V.2			
VUT 250 VBE EC A21		-	NKD-160 A21 V.2	SH-32		
VUT 250 VB EC A14		-	-			
VUE 250 VB EC A21		-	NKD-160 A21 V.2			
VUE 250 VBE EC A21		-	NKD-160 A21 V.2	-		
VUE 250 VB EC A14		-	-			
VUT 350 V1B EC A21		NKP-160 A21 V.2	NKD-160 A21 V.2	SH-32	KRV 160	
VUT 350 V1B EC A14		-	-			
VUE 350 V1B EC A21		NKP-160 A21 V.2	NKD-160 A21 V.2	-		
VUE 350 V1B EC A14		-	-			
VUT 350 VB EC A21		NKP-160 A21 V.2	NKD-160 A21 V.2	SH-32		
VUT 350 VB EC A14		-	-			
VUE 350 VB EC A21		NKP-160 A21 V.2	NKD-160 A21 V.2	-		
VUE 350 VB EC A14		-	-			
VUT 550 VB EC A21		NKP-200 A21 V.2	NKD-200 A21 V.2	SH-32	KRV 200	
VUT 550 VB EC A14		-	-			
VUE 550 VB EC A21	NKP-200 A21 V.2	NKD-200 A21 V.2	-			
VUE 550 VB EC A14	-	-				

Series

**VENTS VUT/VUE HB EC**  
**VENTS VUT/VUE HBE EC**



Heat recovery air handling units in sound- and heat-insulated casings  
Air flow up to **830 m<sup>3</sup>/h**  
Heat recovery efficiency up to **98 %**

**Description**

The VUT/VUE HB EC and VUT/VUE HBE EC air handling units are the fully-featured ventilation units that ensure air filtration, fresh air supply and stale air extract. Used in ventilation and air conditioning systems in commercial, office and other public or industrial premises that require an economical solution and a controlled ventilation system.

**Modifications**

The **VUT HB EC** model is equipped with a counter-flow heat exchanger made of polystyrene. The **VUT HBE EC** model is equipped with a counter-flow heat exchanger made of polystyrene and an electric heater. The **VUE HB EC** model is equipped with with an enthalpy counter-flow heat exchanger. The **VUE HBE EC** model is equipped with an enthalpy counter-flow heat exchanger and an electric heater.

**Casing**

Made of aluzinc steel, internally filled with a 40 mm mineral wool heat- and sound-insulating layer.

**Filter**

Two built-in panel filters with filtration class G4 and F7 provide efficient supply air filtration. The G4 panel filter is used for extract air cleaning.

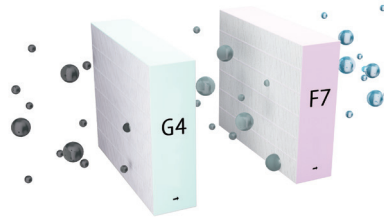

**Fans**

High-efficient electronically-commutated motors with external rotor. The 700 size units are equipped with fans with backward curved blades.

**Heat exchanger**

The VUT units are equipped with a counter-flow polystyrene heat exchanger.

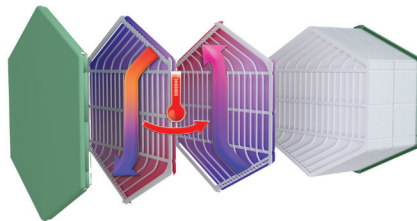

The VUE units are equipped with enthalpy counter-flow heat exchanger.

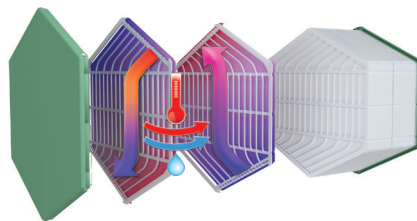

**Heater**

The **VUT/VUE HBE EC** units are equipped with an electric heater for additional heating of supply air downstream of the heat exchanger.

**Bypass**

The unit is equipped for summer cooling. If the unit is equipped with an electric heater, the bypass is used for frost protection of the heat exchanger.

**Automation**

The **VUT/VUE HB(E) EC A21** units are equipped with an integrated control system. The A21 control-

ler allows integrating the unit into the Smart Home system or BMS (Building Management Systems). To control the unit using a mobile application via Wi-Fi, you need to download the VENTS Home mobile application.



**Frost protection**

Frost protection in the **VUT/VUE HBE EC A21** units is achieved by a bypass. A preheater can be additionally installed in the **VUT/VUE HB EC A21** units for frost protection.





**Mounting**

The unit is designed for suspended or floor mounting. Access for service and filter cleaning from the front panel. During mounting stage the front and the back panels can be reversed providing either left-handed or right-handed unit mounting.

**Designation key**

Series	Rated air flow [m <sup>3</sup> /h]	Spigot orientation	Bypass	Heater type	Motor type	Automation
<b>VUT:</b> ventilation with heat recovery <b>VUE:</b> ventilation with energy recovery	300; 400; 700	<b>H:</b> horizontal	<b>B:</b> bypass	<b>_:</b> without a heater <b>E:</b> electric heater	<b>EC:</b> synchronous electronically commutated motor	<b>A21</b>

**Control and automation**

Functions	A21
Control via Wi-Fi using a mobile application	+
Control via a wired remote control panel	option (A22) 
Wired remote LCD control panel	option (A25) 
Control via a wireless remote control panel	option (A22 Wi-Fi) 
BMS	RS-485 WI-FI Ethernet MODBUS (RTU, TCP)
Service Vents Cloud Server	+
Speed selection	+
Filter replacement indication	according to hour meter readings according to filter clogging differential pressure switch readings
Alarm indication	full alarm description in the mobile application
Week-scheduled operation	+
Bypass	automatic manual
Timers	+
Boost mode	+
Fireplace mode	+
Frost protection	through cyclic stops of the supply fan through preheating (option) using a bypass
Reheater connection	option
Preheater connection	option
Minimum supply air temperature control	+
Humidity control	option
CO <sub>2</sub> controller	option
VOC controller	option
PM2.5 control	option
Fire alarm sensor connection	option

\*Option. The functionality is available when you purchase the appropriate accessory.

**Overall dimensions**

Model	Dimensions [mm]								
	Ø D	B	B1	B2	H	H1	H2	L	L1
VUT/VUE 300 HB(E) EC	157	566	190	189	479	193	118	1083	1180
VUT/VUE 400 HB(E) EC	197	682	248	217	504	201	141	1094	1191
VUT/VUE 700 HB(E) EC	247	866	274	296	601	234	166	1282	1379

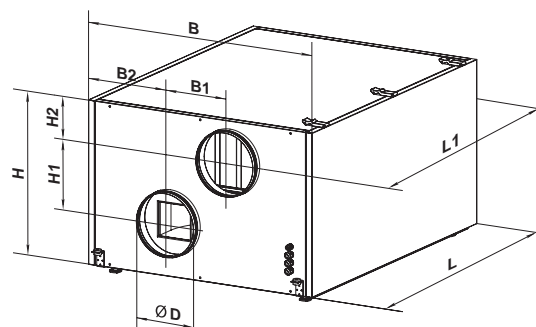

# COUNTERFLOW HEAT RECOVERY UNITS IN METAL CASING

## Technical data

	VUT 300 HB EC A21	VUT 300 HBE EC A21	VUE 300 HB EC A21	VUE 300 HBE EC A21
Unit voltage [V/50 (60) Hz]	1~230			
Maximum unit power (without a heater) [W]	182		182	
Maximum unit current (without a heater) [A]	1.4		1.4	
Electric heater power [W]	-	2800	-	2800
Electric heater current [A]	-	12.2	-	12.2
Maximum unit power with an electric heater [W]	182	2982	182	2982
Maximum unit current (with an electric heater) [A]	1.4	13.6	1.4	13.6
Maximum air flow [m <sup>3</sup> /h]	380		380	
Sound pressure level at 3 m distance [dBA]	24		24	
Maximum transported air temperature [°C]	-25...+40			
Casing material	galvanized steel			
Insulation	40 mm mineral wool			
Filter: extract	G4			
Filter: supply	G4+F7			
Connected air duct diameter [mm]	Ø160		Ø160	
Weight [kg]	63.1	64.3	63.1	64.3
Heat recovery efficiency	from 80 up to 98 %		from 74 up to 89 %	
Heat exchanger type	counter-flow			
Heat exchanger material	polystyrene		enthalpy membrane	
SEC class	A+	A+	A	A

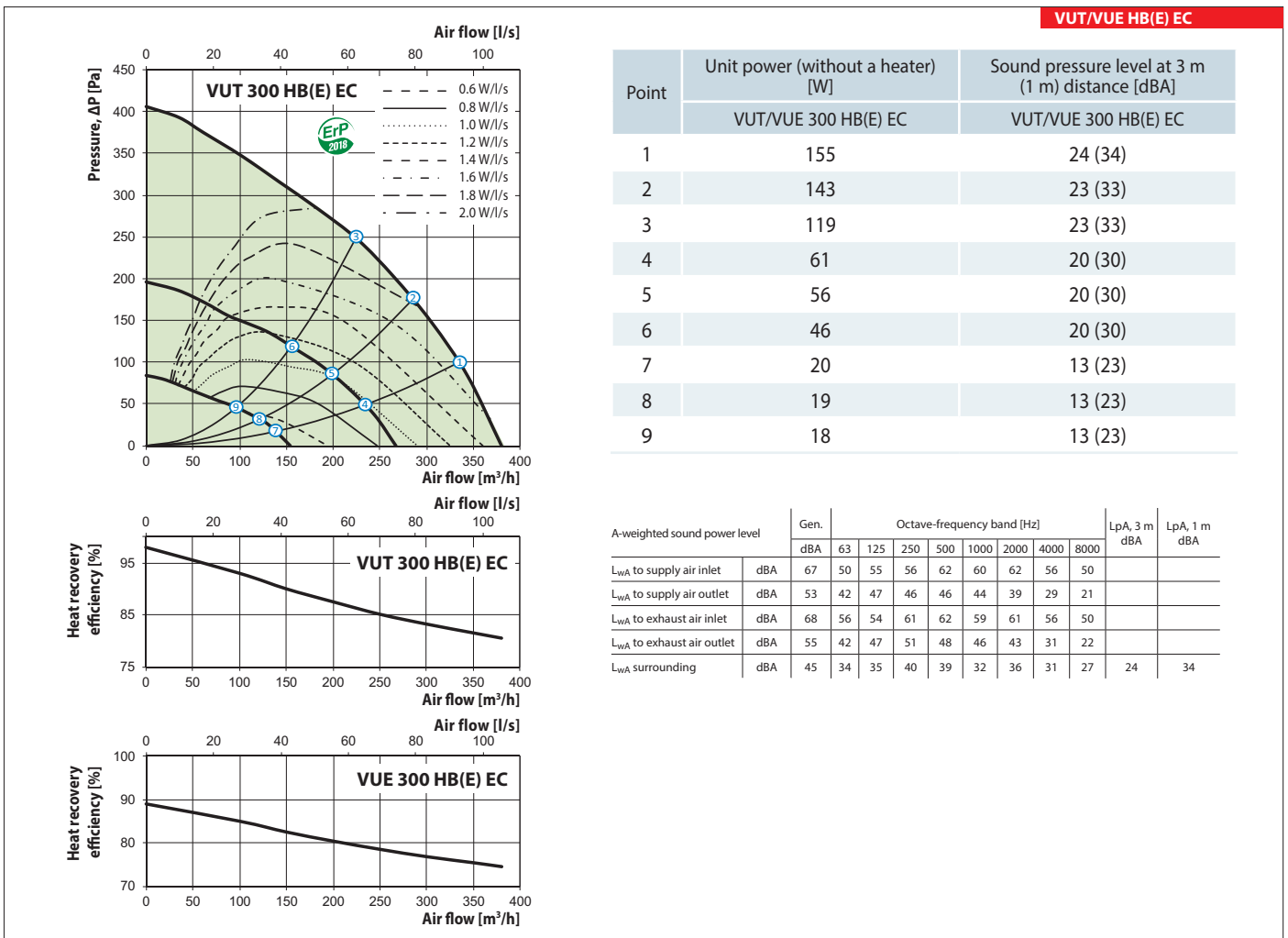

	VUT 400 HB EC A21	VUT 400 HBE EC A21	VUE 400 HB EC A21	VUE 400 HBE EC A21
Unit voltage [V/50 (60) Hz]	1~230			
Maximum unit power (without a heater) [W]	289		289	
Maximum unit current (without a heater) [A]	2.1		2.1	
Electric heater power [W]	-	2800	-	2800
Electric heater current [A]	-	12.2	-	12.2
Maximum unit power with an electric heater [W]	289	3089	289	3089
Maximum unit current (with an electric heater) [A]	2.1	14.3	2.1	14.3
Maximum air flow [m <sup>3</sup> /h]	540		540	
Sound pressure level at 3 m distance [dBA]	27		27	
Maximum transported air temperature [°C]	-25...+40			
Casing material	galvanized steel			
Insulation	40 mm mineral wool			
Filter: extract	G4			
Filter: supply	G4+F7			
Connected air duct diameter [mm]	Ø200		Ø200	
Weight [kg]	74.8	76	74.8	76
Heat recovery efficiency	from 84 up to 98 %		from 78 up to 89 %	
Heat exchanger type	counter-flow			
Heat exchanger material	polystyrene		enthalpy membrane	
SEC class	A+	A+	A	A

VUT/VUE HB(E) EC

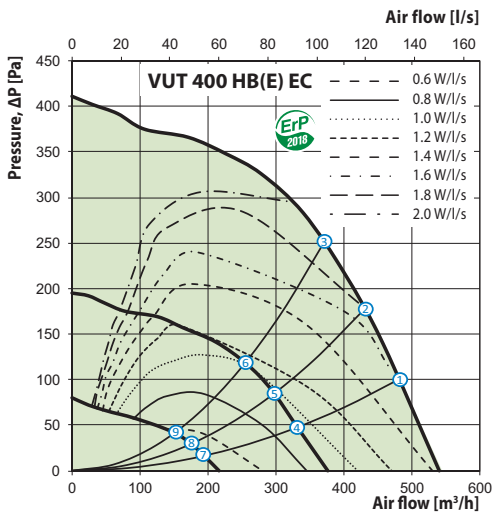

Point	Unit power (without a heater) [W]	Sound pressure level at 3 m (1 m) distance [dBA]
	VUT/VUE 400 HB(E) EC	VUT/VUE 400 HB(E) EC
1	240	27 (37)
2	215	26 (36)
3	196	26 (36)
4	89	21 (31)
5	80	21 (31)
6	72	20 (30)
7	27	19 (29)
8	26	19 (29)
9	24	17 (27)

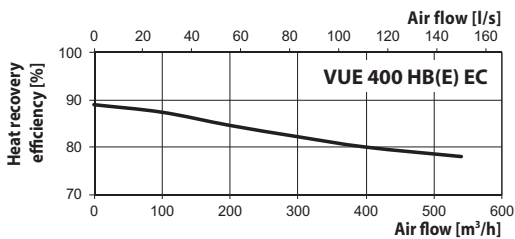
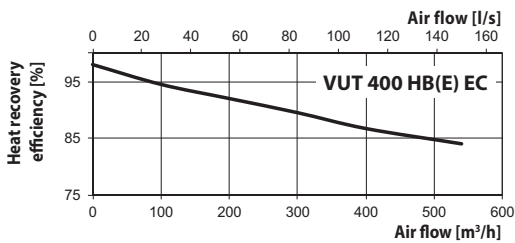

A-weighted sound power level	Gen. dBA	Octave-frequency band [Hz]								LpA, 3 m dBA	LpA, 1 m dBA	
		63	125	250	500	1000	2000	4000	8000			
L <sub>WA</sub> to supply air inlet	dBA	71	52	57	57	68	64	64	59	53		
L <sub>WA</sub> to supply air outlet	dBA	56	44	49	47	52	47	41	31	24		
L <sub>WA</sub> to exhaust air inlet	dBA	70	52	56	60	66	62	64	60	53		
L <sub>WA</sub> to exhaust air outlet	dBA	58	39	49	52	53	49	46	35	24		
L <sub>WA</sub> surrounding	dBA	48	32	37	40	45	36	38	35	30	27	37

# COUNTERFLOW HEAT RECOVERY UNITS IN METAL CASING

## Technical data

	VUT 700 HB EC A21	VUT 700 HBE EC A21	VUE 700 HB EC A21	VUE 700 HBE EC A21
Unit voltage [V/50 (60) Hz]	1~230			
Maximum unit power (without a heater) [W]	336		336	
Maximum unit current (without a heater) [A]	2.4		2.4	
Electric heater power [W]	-	3600	-	3600
Electric heater current [A]	-	15.6	-	15.6
Maximum unit power with an electric heater [W]	336	3936	336	3936
Maximum unit current (with an electric heater) [A]	2.4	18.0	2.4	18.0
Maximum air flow [m <sup>3</sup> /h]	830		830	
Sound pressure level at 3 m distance [dBA]	31		31	
Maximum transported air temperature [°C]	-25...+40			
Casing material	galvanized steel			
Insulation	40 mm mineral wool			
Filter: extract	G4			
Filter: supply	G4+F7			
Connected air duct diameter [mm]	Ø250		Ø250	
Weight [kg]	107	108.4	107	108.4
Heat recovery efficiency	from 80 up to 98 %		from 74 up to 89 %	
Heat exchanger type	counter-flow			
Heat exchanger material	polystyrene		enthalpy membrane	
SEC class	A+	A+	A	A

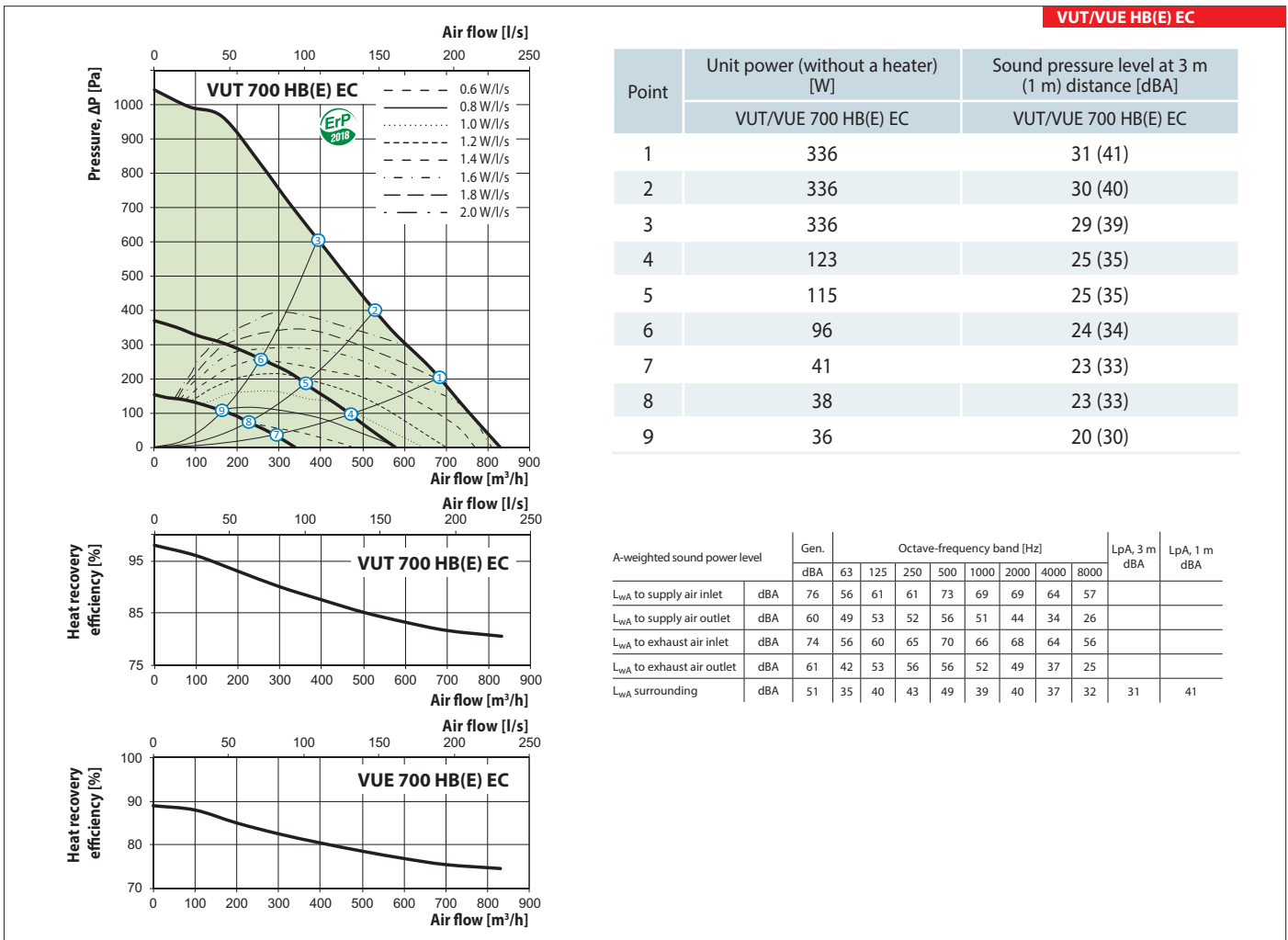

**Accessories for air handling units**

Model	G4 panel filter	F7 panel filter	LCD control panel	Control panel	Wi-Fi controllable control	Humidity sensor (0-10 V)	CO <sub>2</sub> sensor	CO <sub>2</sub> sensor with indication	Humidity sensor
VUT/VUE 300 HB EC A21	SF 484x178x48	SF 484x178x48	A25	A22	A22 Wi-Fi	HV2	CO2-1	CO2-2	HR-S
VUT/VUE 300 HBE EC A21	G4	F7							
VUT/VUE 400 HB EC A21	SF 600x205x48	SF 600x205x48	A25	A22	A22 Wi-Fi				
VUT/VUE 400 HBE EC A21	G4	F7							
VUT/VUE 700 HB EC A21	SF 784x253x48	SF 784x253x48	A25	A22	A22 Wi-Fi				
VUT/VUE 700 HBE EC A21	G4	F7							

Model	Electric reheater	Electric heater for preheating	Silencers	Back valves	Air dampers	Electric actuator
VUT/VUE 300 HB EC A21	NKD 160 A21 V.2	NKP 160 A21 V.2	SR 160 600/900/1200	KOM 160	KRV 160	TF230
VUT/VUE 300 HBE EC A21	-	NKP 160 A21 V.2				
VUT/VUE 400 HB EC A21	NKD 200 A21 V.2	NKP 200 A21 V.2	SR 200 600/900/1200	KOM 200	KRV 200	
VUT/VUE 400 HBE EC A21	-	NKP 200 A21 V.2				
VUT/VUE 700 HB EC A21	NKD 250 A21 V.2	NKP 250 A21 V.2	SR 250 600/900/1200	KOM 250	KRV 250	
VUT/VUE 700 HBE EC A21	-	NKP 250 A21 V.2				

**Unit design**

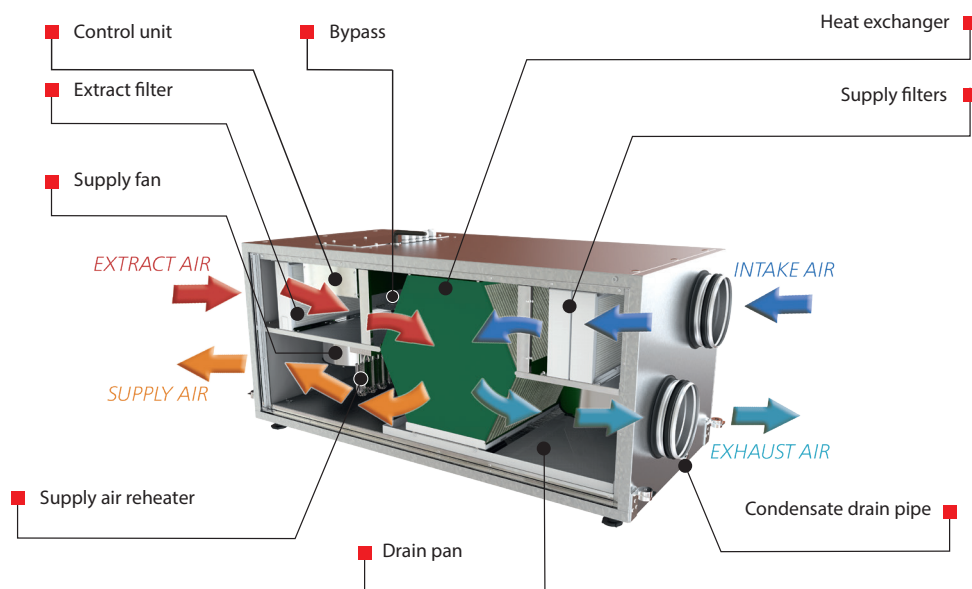

Application options

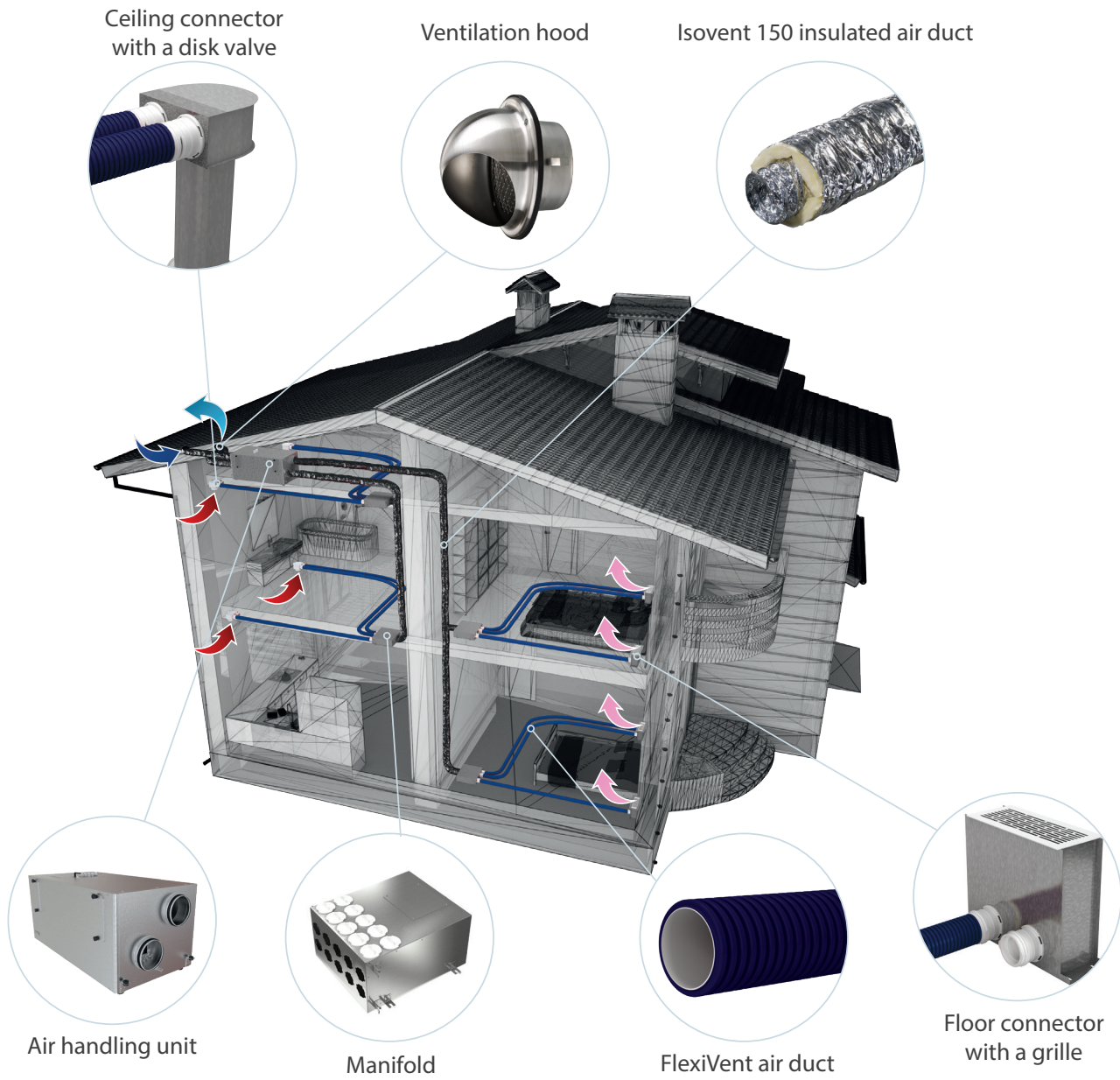



Series  
**VENTS VUT/VUE PBE EC**  
**VENTS VUT/VUE PBW EC**



Ceiling mounted air handling units in compact heat- and sound-insulated casing with an electric heater.  
 Air flow up to **4300 m<sup>3</sup>/h**, heat recovery efficiency up to **90 %**.

■ **Description**

The VUT/VUE PBE EC air handling unit with an electric heater and the VUT/VUE PBW EC air handling unit with a water heater are the fully-featured ventilation units ensuring air filtration, fresh air supply and stale air extraction. The units are suitable for integration into various ventilation and air conditioning networks requiring cost-effective solutions and controllable ventilation.

■ **Modifications**

- VUT PBE EC** – models with an electric heater and a polystyrene or aluminium heat exchanger.
- VUE PBE EC** – models with an electric heater and an enthalpy heat exchanger.
- VUT PBW EC** – models with a water heater and a polystyrene or aluminium heat exchanger.
- VUE PBW EC** – models with a water heater and an enthalpy heat exchanger.

■ **Casing**

The heat- and sound-insulated aluzinc casing is internally filled with mineral wool.

■ **Filter**

To filter the supply and extract air, the unit has two built-in G4 filters. For the VUT/VUE 300/550/900 PBE/PBW EC models, a supply filter with an F7 degree of filtration can be installed as an option.

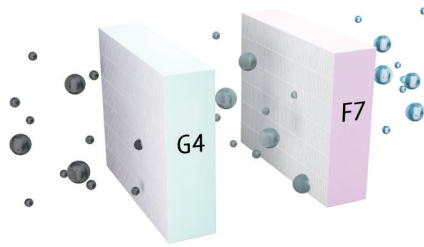

■ **Motor**

High-efficient electronically-commutated motors with external motor and impellers with backward curved blades.

■ **Heat exchanger**

A plate counter-flow polystyrene heat exchanger which returns heat is used in the VUT 300/550/900 PBE/PBW EC units.

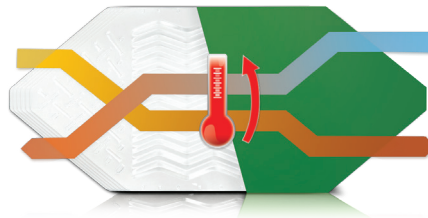

The VUT 2000/3000 PBE/PBW EC units are equipped with a cross-flow plate heat exchanger made of aluminium.

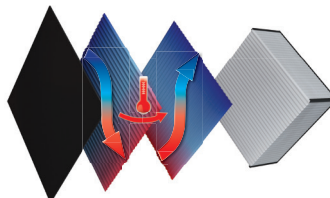

The VUE 300/550/900 PBE/PBW EC units are equipped with enthalpy counter-flow heat exchanger.

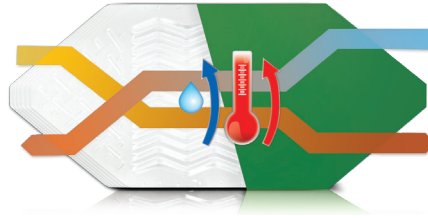

■ **Bypass**

The units are equipped with a bypass for summer cooling.

■ **Heater**

The electric heater (for the VUT/VUE PBE EC unit) or the water heater (for the VUT/VUE PBW EC unit), installed downstream of the heat exchanger. The water heaters are designed for max. operating pressure of 1.0 MPa (10 bar) and max. heat carrier operating temperature of +95 °C.

■ **Control and automation**

The units are equipped with an integrated automation system. The A21 controller enables integration of the unit into the **Smart Home System** or **BMS (Building Management Systems)**. To control the unit via Wi-Fi, download the VENTS Home mobile app.

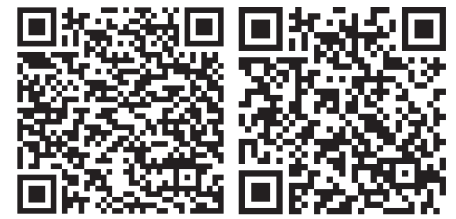

Google play

Download on the App Store





■ **Mounting**

The unit is designed for indoor mounting. While mounting the unit ensure its correct position to enable condensate collection and drainage.

**Designation key**

Series	Rated air flow [m <sup>3</sup> /h]	Mounting modification	Bypass	Heater type	Motor type	Service side	Control	Accessories
<b>VUT:</b> ventilation with heat recovery <b>VUE:</b> ventilation with energy recovery	300; 550; 900; 2000; 3000	<b>P:</b> suspended	<b>B:</b> Bypass	<b>E:</b> electric <b>W:</b> water	<b>EC:</b> synchronous electronically commutated motor	<b>L:</b> left <b>R:</b> right	<b>A21</b>	<b>DTV:</b> equipped with a differential pressure switch for controlling the contamination of filters

**Control and automation**

Functions	A21
Wi-Fi control via mobile application	+
Control via wired remote control panel	option (A22) 
Control via wired remote LCD control panel	option (A25) 
Control via wireless remote control panel	option (A22 Wi-Fi) 
BMS	RS-485 WI-FI Ethernet MODBUS (RTU, TCP)
Service Vents Cloud Server	+
Speed selection	+
Filter replacement indication	according to a filter timer according to a pressure switch of filter clogging for the units with DTV
Alarm indication	full alarm description in the mobile application
Week-scheduled operation	+
Bypass	auto
	manual
Timer	+
Boost mode	+
Fireplace mode	+
Frost protection	cyclic shutdown of the supply fan
	through preheating (option) using a bypass
Preheater connection	option
Control of minimum supply air temperature	+
Humidity control	option
CO <sub>2</sub> control	option
VOC control	option
PM2.5 control	option
Fire alarm sensor	option

\*Option. The functionality is available when you purchase the appropriate accessory.

## COUNTERFLOW HEAT RECOVERY UNITS IN METAL CASING

### Unit overall dimensions

Type	Dimensions [mm]					
	ØD	B	B1	H	L	L1
VUT/VUE 300 PBE EC	160	485	577	280	1238	1291
VUT/VUE 550 PBE/PBW EC	200	827	960	280	1238	1291
VUT/VUE 900 PBE/PBW EC	250	1351	1485	318	1349	1402
VUT 2000 PBE/PBW EC	315	950	-	762	1400	1452
VUT 3000 PBE/PBW EC	400	1265	-	881	1835	1888

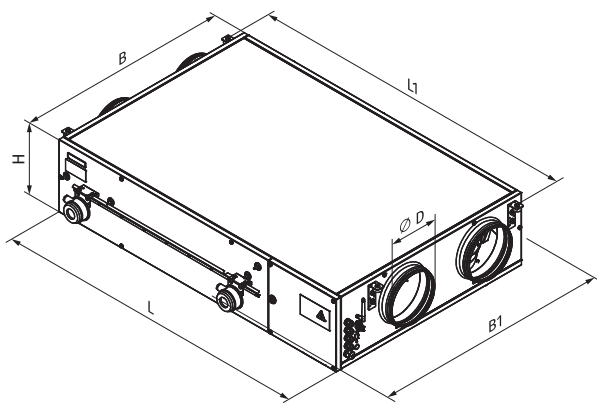

VUT/VUE 550 PBE EC  
VUT/VUE 550 PBW EC

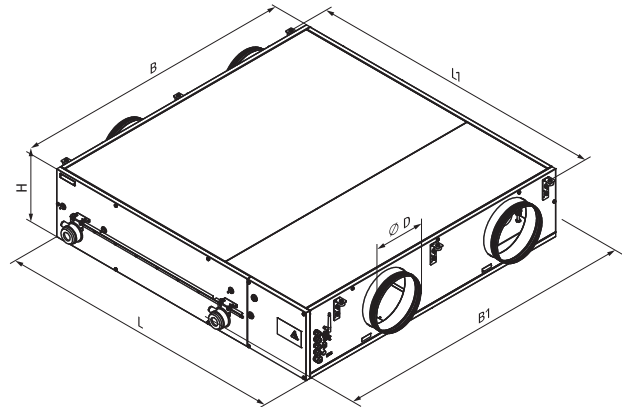

VUT/VUE 900 PBE EC  
VUT/VUE 900 PBW EC

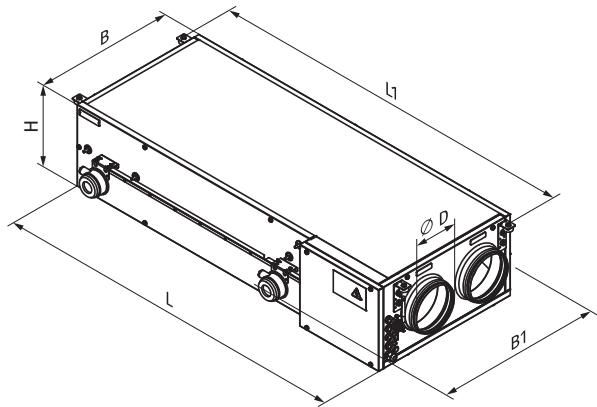

VUT/VUE 300 PBE EC

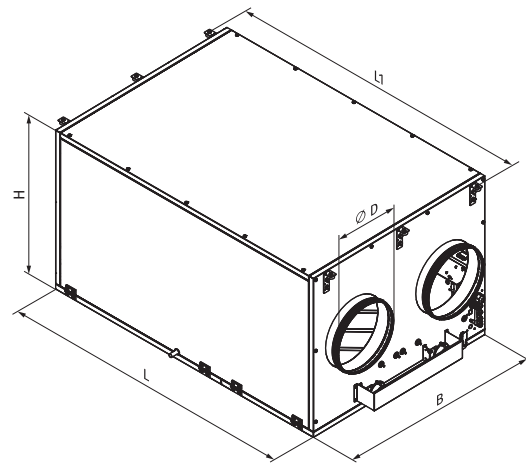

VUT 2000(3000) PBE EC  
VUT 2000(3000) PBW EC

**Technical data**

	VUT 300 PBE EC	VUE 300 PBE EC	VUT 550 PBE EC	VUE 550 PBE EC	VUT 550 PBW EC	VUE 550 PBW EC
Voltage [V/50-60 Hz]	1~230		1~230		1~230	
Max. unit power without electric heater [W]	180		322		322	
Integrated electric heater power [W]	1500		2000		-	
Max. unit power with electric heater [W]	1 680		2 322		322	
Max. unit current without electric heater [A]	1.4		2.4		2.4	
Integrated electric heater current [A]	6.5		8.7		-	
Max. unit current with electric heater [A]	7.9		11.1		2.4	
Number of water (glycol) coil rows	-		-		2	
Max. air flow [m <sup>3</sup> /h]	340		608		608	
Sound pressure level at 3 m distance [dBA]	27		30		30	
Max. transported air temperature [°C]			-25...+40			
Casing material	aluzinc					
Insulation	20 mm, mineral wool					
Extract filter	G4					
Supply filter	G4 (F7 option)					
Connected air duct diameter [mm]	160		200		200	
Weight [kg]	44		67		68	
Heat recovery efficiency [%]	72-90	69-87	78-90	69-87	78-90	69-87
Heat exchanger type	counter-flow					
Heat exchanger material	polystyrene	enthalpy membrane	polystyrene	enthalpy membrane	polystyrene	enthalpy membrane
SEC class	A		A		A	

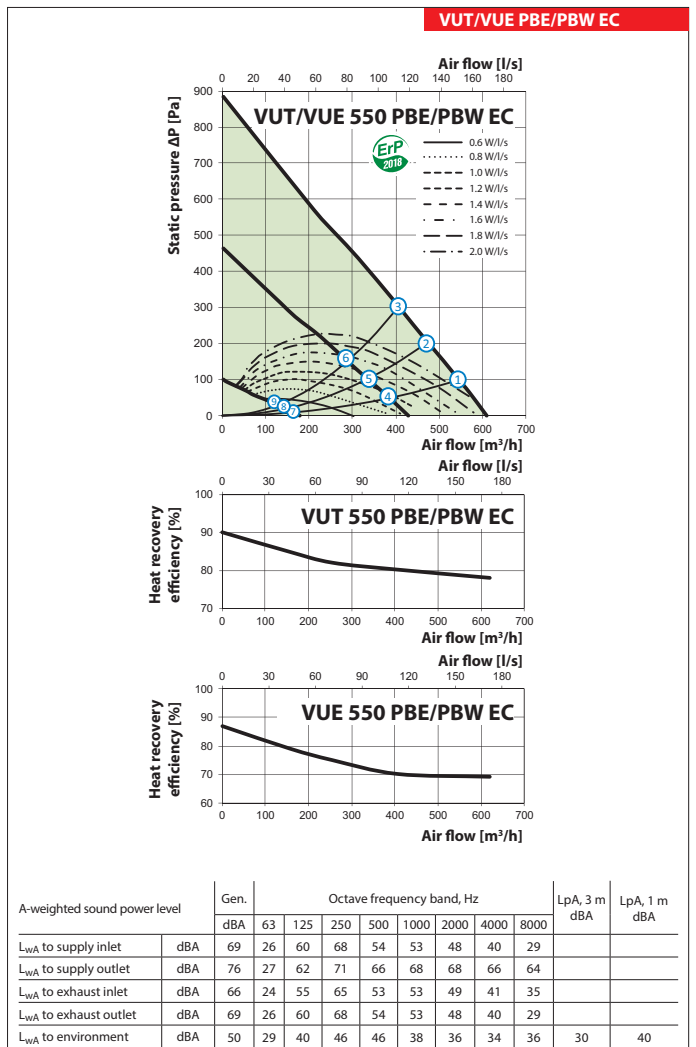
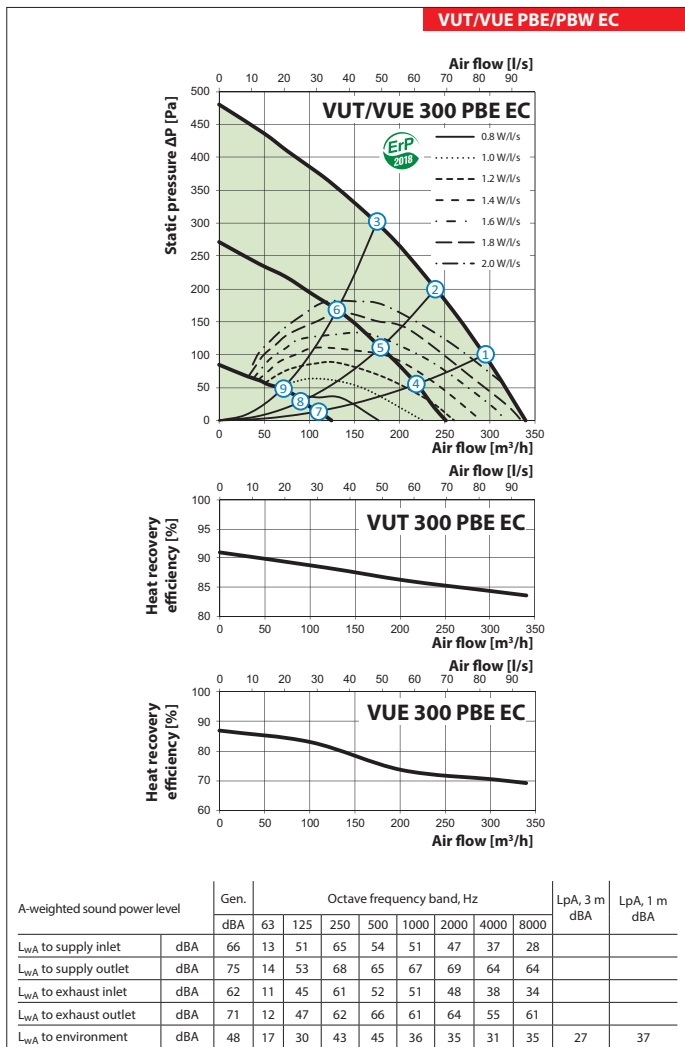

# COUNTERFLOW HEAT RECOVERY UNITS IN METAL CASING

## Technical data

	VUT 900 PBE EC	VUE 900 PBE EC	VUT 900 PBW EC	VUE 900 PBW EC
Voltage [V/50-60 Hz]	1~230		1~230	
Max. unit power without electric heater [W]	442		442	
Integrated electric heater power [W]	3300		-	
Max. unit power with electric heater [W]	3742		442	
Max. unit current without electric heater [A]	3.1		3	
Integrated electric heater current [A]	14.3		-	
Max. unit current with electric heater [A]	17.4		3	
Number of water (glycol) coil rows	-		2	
Max. air flow [m <sup>3</sup> /h]	1030		1030	
Sound pressure level at 3 m distance [dBA]	33		33	
Max. transported air temperature [°C]	-25...+40		-25...+40	
Casing material	aluzinc			
Insulation	20 mm, mineral wool			
Extract filter	G4			
Supply filter	G4 (F7 option)			
Connected air duct diameter [mm]	250		250	
Weight [kg]	111		112	
Heat recovery efficiency [%]	75-88	69-85	75-88	69-85
Heat exchanger type	counter-flow			
Heat exchanger material	polystyrene	enthalpy membrane	polystyrene	enthalpy membrane
SEC class	A	A	A	A

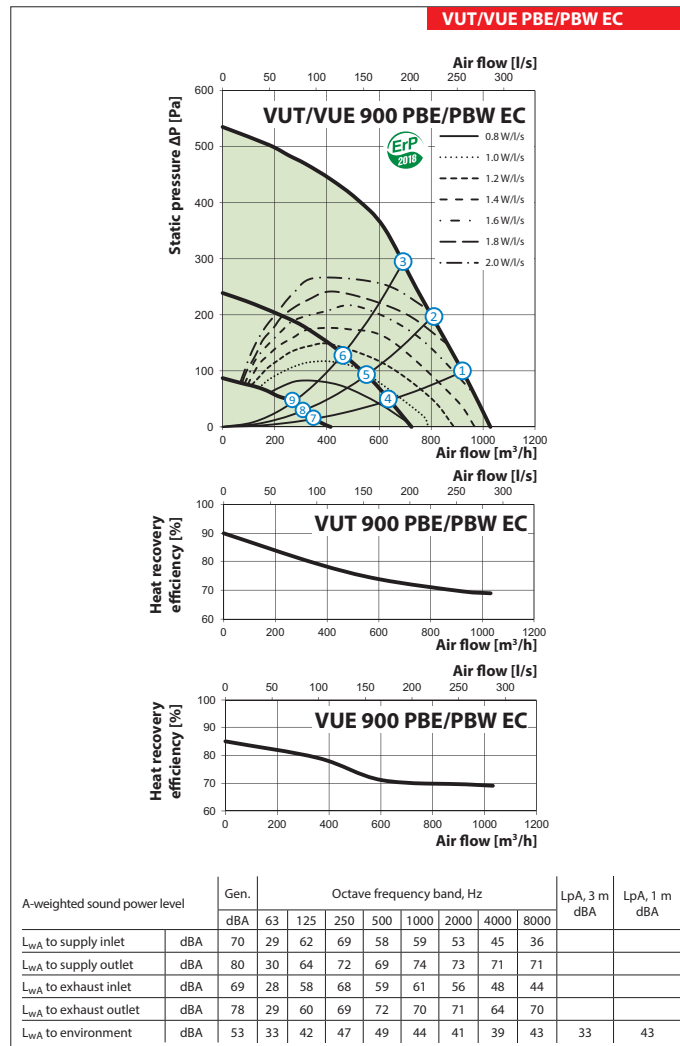

**Technical data**

	VUT 2000 PBE EC	VUT 2000 PBW EC	VUT 3000 PBE EC	VUT 3000 PBW EC
Voltage [V/50-60 Hz]	3~400	1~230	3~400	
Max. unit power without electric heater [W]		1063		2226
Integrated electric heater power [W]	15000	-	21000	-
Max. unit power with electric heater [W]	16063	876	23226	2 226
Max. unit current without electric heater [A]		4.7		3.5
Integrated electric heater current [A]	21.7	-	30	-
Max. unit current with electric heater [A]	26.4	5.3	33.5	3.5
Number of water (glycol) coil rows	-	2	-	2
Max. air flow [m <sup>3</sup> /h]		2100		4300
Sound pressure level at 3 m distance [dBA]		36		46
Max. transported air temperature [°C]		-25...+40		-25 ....+40
Casing material	aluzinc			
Insulation	20 mm, mineral wool			
Extract filter	G4			
Supply filter	G4			
Connected air duct diameter [mm]		315		400
Weight [kg]		140		281
Heat recovery efficiency [%]		50-67		59-72
Heat exchanger type	cross-flow type			
Heat exchanger material	aluminum			
SEC class	NRVU			

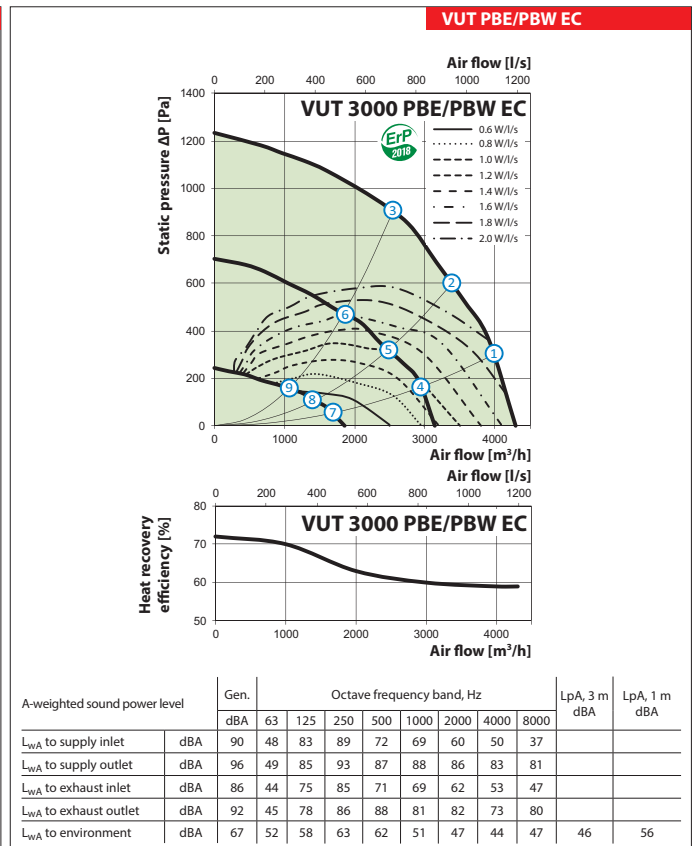
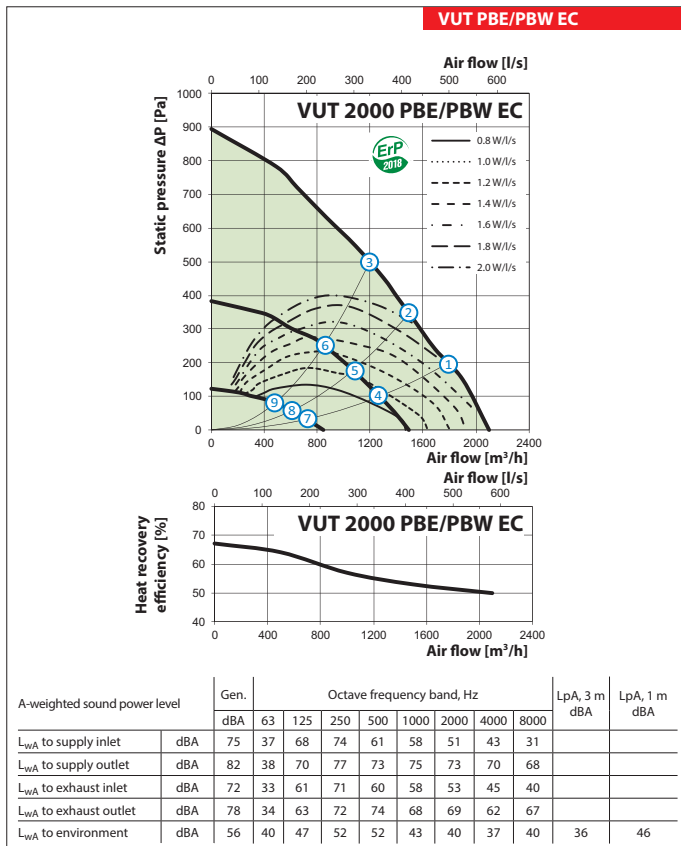

## COUNTERFLOW HEAT RECOVERY UNITS IN METAL CASING

Point	Unit power [W]				
	VUT/VUE 300 PBE EC	VUT/VUE 550 PBE/PBW EC	VUT 900 PBE/PBW EC	VUT 2000 PBE/PBW EC	VUT 3000 PBE/PBW EC
1	174	322	442	1061	2200
2	168	322	442	1061	2220
3	152	321	442	1062	2143
4	77	121	160	448	858
5	74	121	149	448	868
6	68	121	147	448	840
7	19	16	46	84	198
8	19	16	43	83	200
9	18	16	40	83	162

### Accessories for air handling units

Model	G4 pocket filter	F7 pocket filter	G4 panel filter	Control panel	Wi-Fi controllable control panel	LCD control panel	Humidity sensor (0-10 V)	CO <sub>2</sub> sensor	CO <sub>2</sub> sensor with indication	Humidity sensor	Electric heater for preheating
VUT 300 PBE EC A21	SFK 208x236x27 G4	SFK 208x236x27 F7	SF 440x128x20 G4								
VUT 550 PBE EC A21	SFK 392x236x27 G4	SFK 392x236x27 F7	SF 782x128x20 G4								
VUT 900 PBE EC A21	SFK 647x274x27 G4	SFK 647x274x27 F7	SF 647x274x20 G4								
VUE 300 PBE EC A21	SFK 208x236x27 G4	SFK 208x236x27 F7	SF 440x128x20 G4								
VUE 550 PBE EC A21	SFK 392x236x27 G4	SFK 392x236x27 F7	SF 782x128x20 G4								
VUE 900 PBE EC A21	SFK 647x274x27 G4	SFK 647x274x27 F7	SF 647x274x20 G4								
VUT 2000 PBE EC A21	-	-	SF 708x480x48 G4								
VUT 3000 PBE EC A21	-	-	SF 827x741x48 G4	A22	A22 WiFi	A25	HV2	CO2-1	CO2-2	HR-S	NKP A21 V.2
VUT 550 PBW EC A21	SFK 392x236x27 G4	SFK 392x236x27 F7	SF 782x128x20 G4								
VUT 900 PBW EC A21	SFK 647x274x27 G4	SFK 647x274x27 F7	SF 647x274x20 G4								
VUE 550 PBW EC A21	SFK 392x236x27 G4	SFK 392x236x27 F7	SF 782x128x20 G4								
VUE 900 PBW EC A21	SFK 647x274x27 G4	SFK 647x274x27 F7	SF 647x274x20 G4								
VUT 2000 PBW EC A21	-	-	SF 708x480x48 G4								
VUT 3000 PBW EC A21	-	-	SF 827x741x48 G4								

Model	Hydraulic U-trap	Silencer	Backdraft damper	Air damper	Electric actuators	Mixing unit
VUT 300 PBE EC A21		SR 160 600/900/1200	KOM 160	KRV 160	TF230	
VUT 550 PBE EC A21	SH-32	SR 200 600/900/1200	KOM 200	KRV 200		
VUT 900 PBE EC A21		SR 250 600/900/1200	KOM 250	KRV 250		
VUE 300 PBE EC A21		SR 160 600/900/1200	KOM 160	KRV 160		
VUE 550 PBE EC A21	-	SR 200 600/900/1200	KOM 200	KRV 200		
VUE 900 PBE EC A21		SR 250 600/900/1200	KOM 250	KRV 250		
VUT 2000 PBE EC A21		SR 315 600/900/1200	KOM 315	KRV 315		
VUT 3000 PBE EC A21	SH-32	SR 400 600/900/1200	KOM 400	KRV 400		
VUT 550 PBW EC A21		SR 200 600/900/1200	KOM 200	KRV 200		
VUT 900 PBW EC A21		SR 250 600/900/1200	KOM 250	KRV 250		
VUE 550 PBW EC A21		SR 200 600/900/1200	KOM 200	KRV 200		
VUE 900 PBW EC A21		SR 250 600/900/1200	KOM 250	KRV 250		
VUT 2000 PBW EC A21	SH-32	SR 315 600/900/1200	KOM 315	KRV 315		
VUT 3000 PBW EC A21		SR 400 600/900/1200	KOM 400	KRV 400		

USWK

Water heater parameters calculation

VUT PBW EC

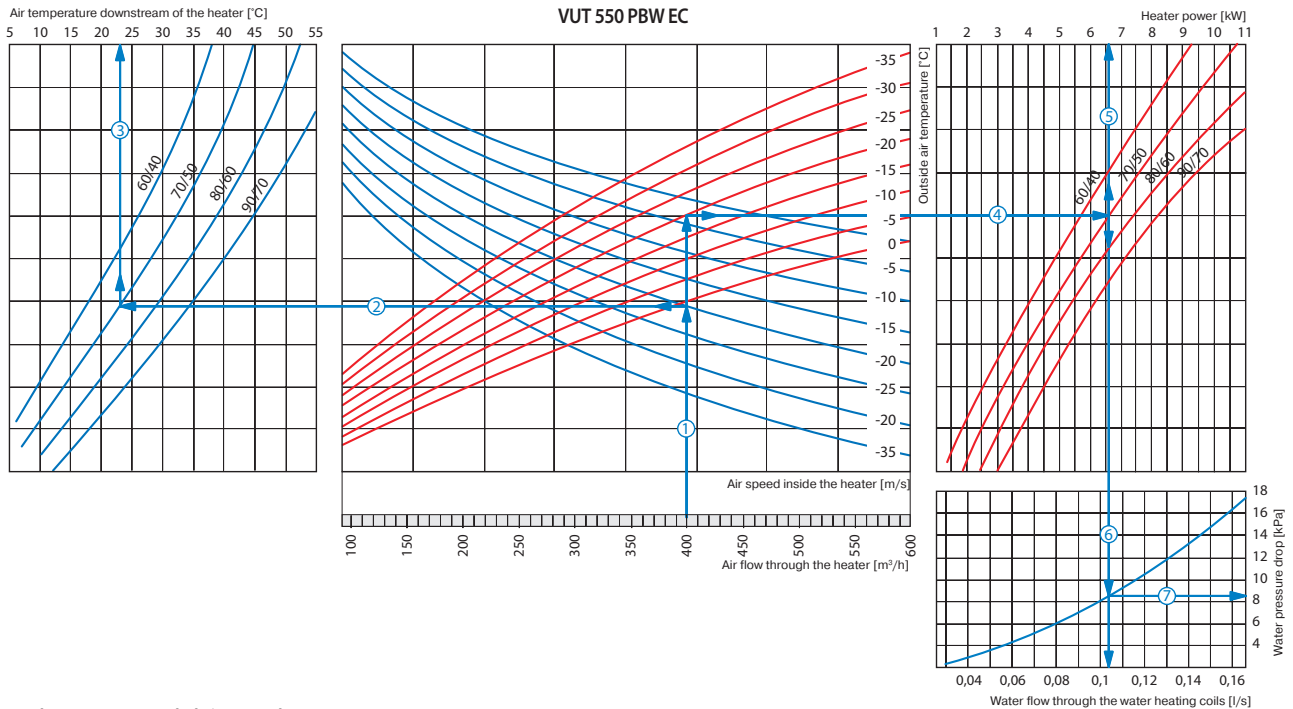

Water heater parameters calculation example

- To calculate the maximum air temperature, find the intersection point of the air flow line ① with the rated winter temperature shown in blue line (e.g., 400 m³/h) and draw the line ② to the left until it crosses the water in/out temperature curve (e.g. +70/+50). From this point draw a vertical line to the supply air temperature downstream of the heater (+23 °C) ③.
- To calculate the heater power, find the intersection point of the air flow ① with the rated winter temperature shown in red line (e.g., -20 °C) and draw the line ④ to the right until it crosses the water in/out temperature curve (e.g. +70/+50). From this point draw a vertical line to the heater power axis (6.6 kW) ⑤.
- To calculate the required water flow in the heater, prolong this line ⑥ downwards to the water flow axis (0,105 l/s).
- To calculate the water pressure drop in the heater, find the intersection point of the line ⑥ with the pressure loss curve and prolong the line ⑦ to the right on the water pressure drop axis (8.5 kPa).

VUT PBW EC

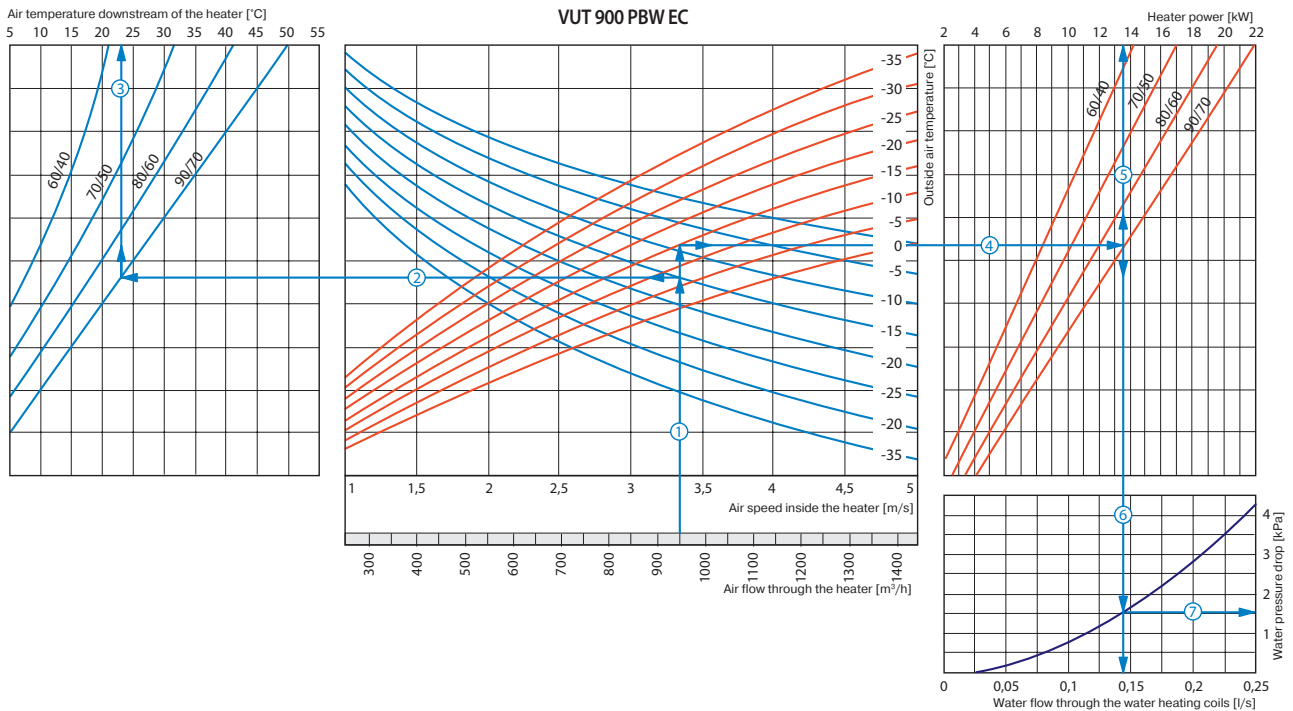

Water heater parameters calculation example

The air flow is 950 m³/h and the air speed in the heater is 3.35 m/s ①.

- To calculate the maximum air temperature, find the intersection point of the air flow line ① with the rated winter temperature shown in blue line (e.g., -15 °C) and draw the line ② to the left until it crosses the water in/out temperature curve (e.g. +90/+70). From this point draw a vertical line to the supply air temperature downstream of the heater (+23 °C) ③.
- To calculate the heater power, find the intersection point of the air flow ① with the rated winter temperature shown in red line (e.g., -20 °C) and draw the line ④ to the right until it crosses the water in/out temperature curve (e.g. +90/+70). From this point draw a vertical line to the heater power axis (13.5 kW) ⑤.
- To calculate the required water flow in the heater, prolong this line ⑥ downwards to the water flow axis (0,14 l/s).
- To calculate the water pressure drop in the heater, find the intersection point of the line ⑥ with the pressure loss curve and prolong the line ⑦ to the right on the water pressure drop axis (1.5 kPa).

### Water heater parameters calculation

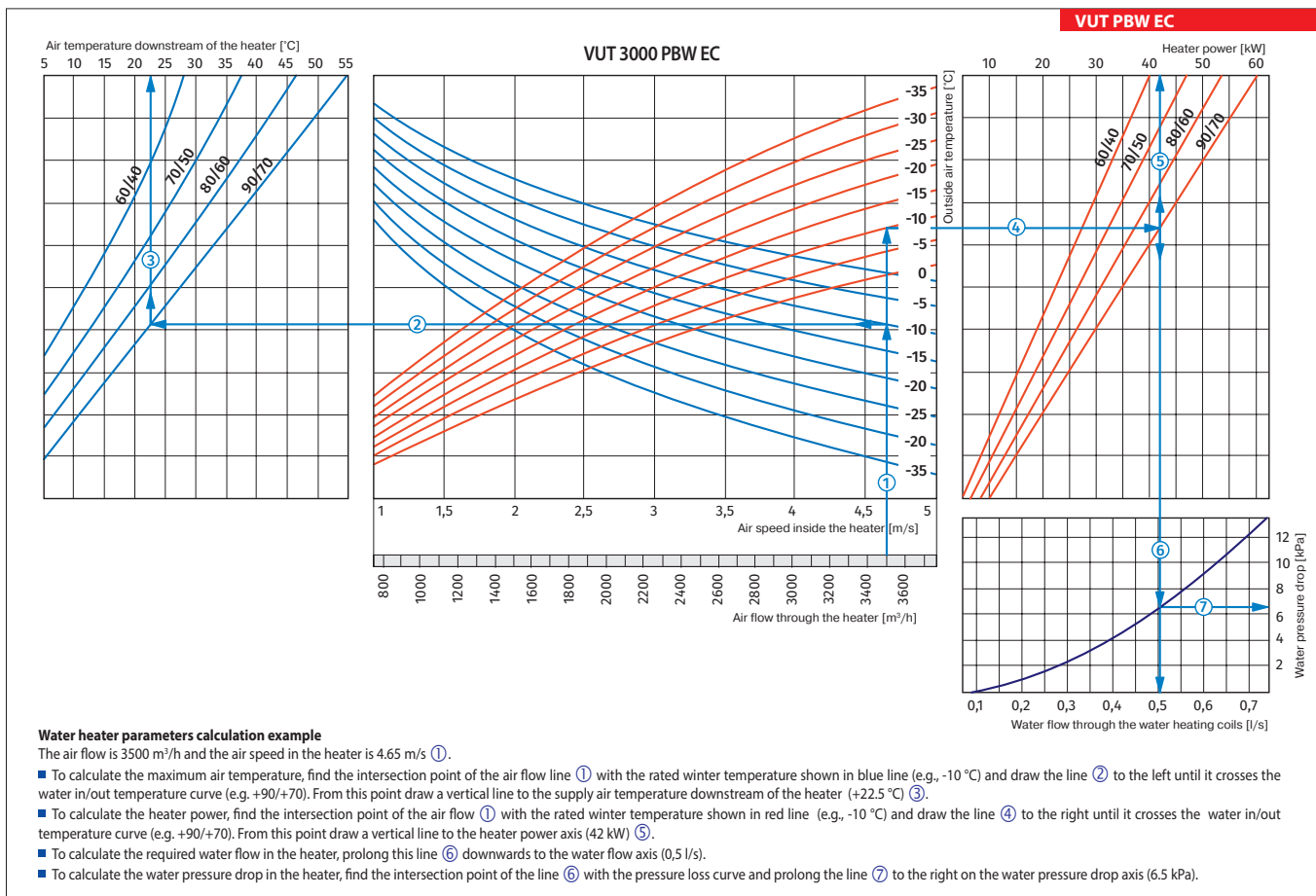
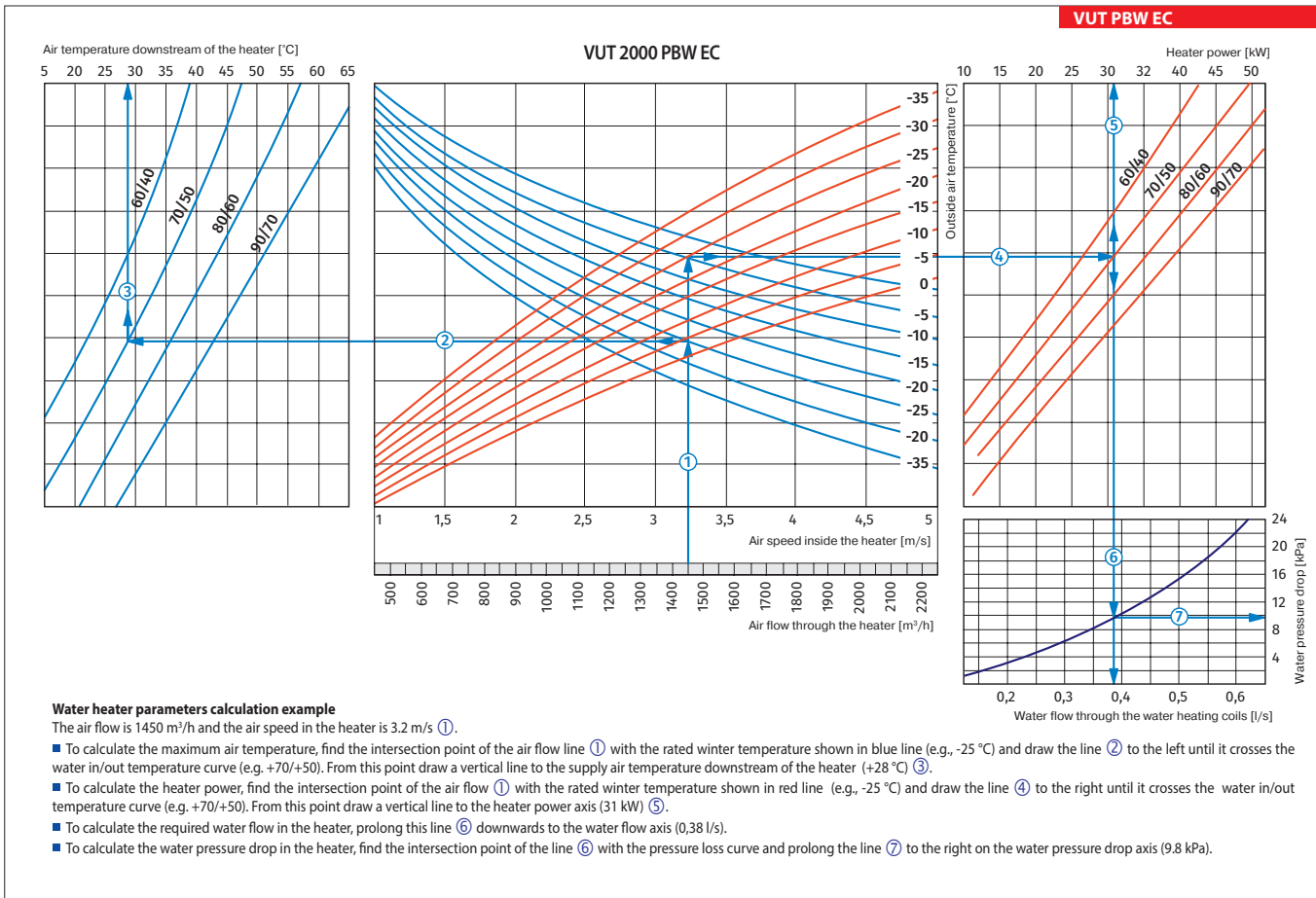

Series  
**VENTS VUT 80 P mini**

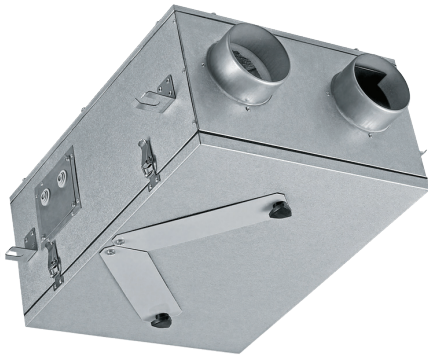

Heat recovery air handling units in sound- and heat-insulated casings.  
Air flow up to **70 m<sup>3</sup>/h**.  
Heat recovery efficiency up to 76 %

**Description**

The air handling units are the fully featured ventilation units with heat recovery for air filtration, fresh air supply and stale air extract. The units offer energy-efficient ventilation for small appartments.

**Casing**

The casing is made of galvanized steel with 15 mm insulation layer possessing high heat- and sound-insulating properties.

**Filter**

Two built-in G4 filters provide efficient air filtration

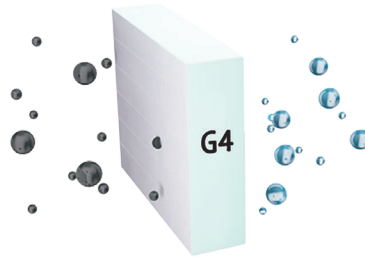

**Fans**

Efficient asynchronous motors with external rotor and impeller with forward curved blades.

**Heat exchanger**

VUT 80 P mini units are equipped with a crossflow polystyrene heat exchanger.

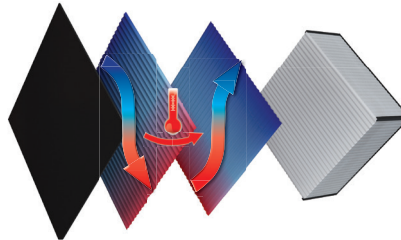

VUE 80 P mini units are equipped with an enthalpy heat exchanger.

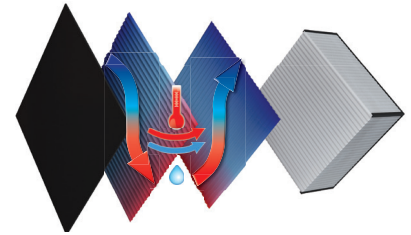

**Automation**

Air flow (speed) is regulated with A3 (P3-1-300) speed switch.

**Freeze protection**

Units freeze protection is provided by the shutdown of the supply fan.

**Mounting**

The unit is designed for suspended ceiling mounting. The mounting position of the unit must provide service access for maintenance and repair.

**Overall dimensions**

Model	Dimensions [mm]							
	L	W	H	L1	W1	W2	W3	D
<b>VENTS VUT 80 P mini</b>	497	374	222	397	404	213	164	125

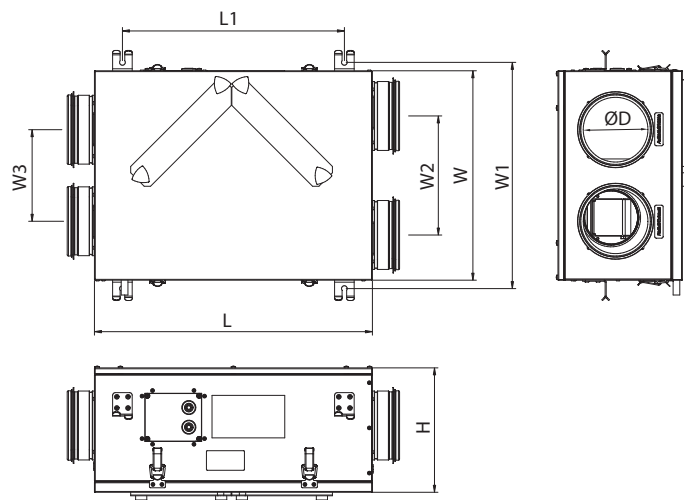

**Designation key**

Series	Size [m <sup>3</sup> /h]	Mounting	Service side	Type
<b>VUT:</b> unit with heat recovery <b>VUE:</b> unit with energy recovery	80	<b>P:</b> suspended unit	<b>L:</b> left <b>R:</b> right	mini

**Technical data**

Model	VUT 80 P L/R mini			VUE 80 P L/R mini		
	I	II	III	I	II	III
Speed						
Voltage [V / 50-60 Hz]	230					
Max. unit power [W]	22	32	56	22	32	56
Max. unit current [A]	0.15	0.2	0.34	0.15	0.2	0.34
Max air flow [m <sup>3</sup> /h]	40	55	70	40	55	70
Sound pressure level at 3 m distance [dBA]	13	15	19	13	15	19
Max. operating temperature [°C]	- 15...+40					
Case material	aluzinc					
Insulation	15 mm PE foam film					
Extract filter	G4 / Coarse > 60%					
Supply filters	G4 / Coarse > 60%					
Connected air duct diameter [mm]	125					
Weight [kg]	10					
Heat recovery efficiency [%]	72-76					
Moisture recuperating efficiency, [%]	-			57-62		
Heat exchanger type	cross-flow					
Heat exchanger material	polysterene			enthalpy membrane		

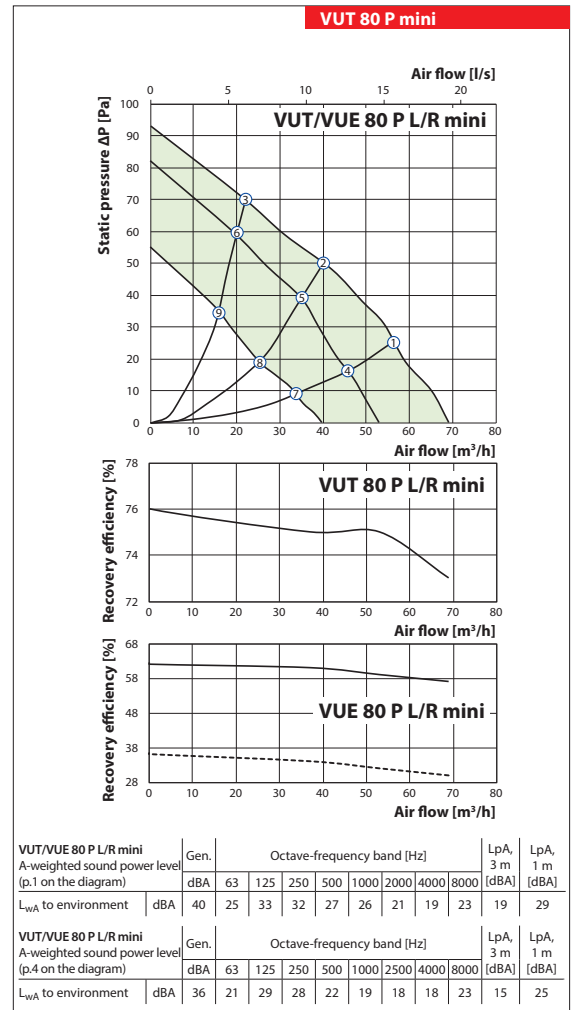

**Accessories for air handling units**

	G4 cassette filter	Silencers	Backdraft dampers	Air dampers	Clamps
VUT 80 P mini	SF 205x198x8 G4	SR 125	KOM 125	KR 125	C 125
VUE 80 P mini					

Series  
**VENTS**  
**VUT/VUE 250 V mini**



Air handling units in compact sound- and heat-insulated casing with vertical duct connections.  
Maximum air flow – **260 m³/h**

■ **Description**

The **VUT/VUE 250 H/V mini A1** air handling units are the fully-featured ventilation units that ensure air filtration, fresh air supply and stale air extract. During the operation process the extract air heat is transferred to the supply air through the plate heat exchanger.

■ **Modifications**

**VUT 250 V mini:** models with vertical duct connections, fans with AC motors with polystyrene heat exchanger.

**VUT 250 H mini:** models with horizontal duct connections, fans with AC motors with polystyrene heat exchanger.

**VUE 250 V mini:** models with vertical duct connections, fans with AC motors with a heat exchanger made of enthalpy.

**VUE 250 H mini:** models with horizontal duct connections, fans with AC motors with a heat exchanger made of enthalpy.

Series  
**VENTS**  
**VUT/VUE 250 H mini**



Air handling units in compact sound- and heat-insulated casing with horizontal duct connections.  
Maximum air flow – **260 m³/h**

■ **Casing**

The casing of the VUT/VUE 250 V/H unit is made of aluzinc steel, internally filled with 20 mm mineral wool heat- and sound-insulating layer.

■ **Filter**

Two built-in filters with filtering class G4 provide efficient supply and extract air filtration. F8 filter is available as an option for supply air filtration.

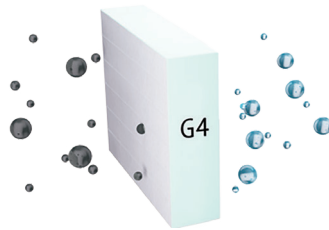

■ **Fans**

The unit is equipped with a supply and exhaust centrifugal fan with backward curved blades and integrated overheating protection thermostat with automatic restart. The motors and the impellers are dynamically balanced.

■ **Heat exchanger**

**VUE mini:** plate heat exchanger made of enthalpy with heat recovery efficiency up to 78%. The applied heat exchanger enables not only heat but also humidity recovery, which helps maintaining a comfortable humidity level.

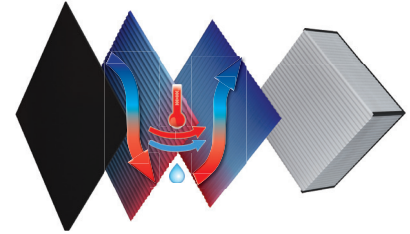

**VUT mini:** plate heat exchanger made of polystyrene. Whenever heat recovery is not required for unit operation, the heat exchanger block can be easily replaced by a summer block.

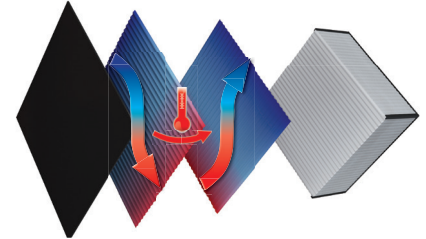

To prevent the heat exchanger freezing, electronic protection system is applied. It switches the supply fan off as the temperature sensor requires.

■ **Control**

The unit is equipped with the A1 control panel. Speed and rotation control of the single-phase power-controlled motors allows turning the unit on/off and controlling its capacity.

■ **Installation**

Mounting to wall, floor or ceiling with fixing brackets. While mounting provide free access to the service panel for filter replacement and servicing. The correct mounted unit must provide condensate collecting and drainage.

**Designation key**

Series	Rated air flow [m³/h]	Spigot modification	Model	Casing colour	Integrated automation system
<b>VUT:</b> ventilation with heat recovery <b>VUE:</b> ventilation with energy recovery	250	<b>V:</b> vertical <b>H:</b> horizontal	<b>mini</b>	<b>_:</b> aluzinc <b>White:</b> white painted	<b>A1:</b> control panel

**Overall dimensions of units**

Model	Dimensions [mm]					
	ØD	B	H	H1	L	L1
VUT/VUE 250 V mini	125	300	443	490	713	43
VUT/VUE 250 H mini	125	300	443	43	713	810

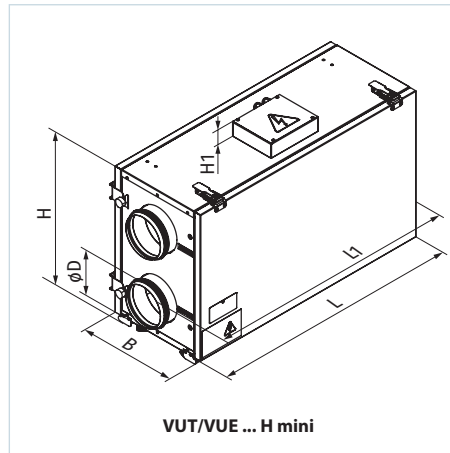
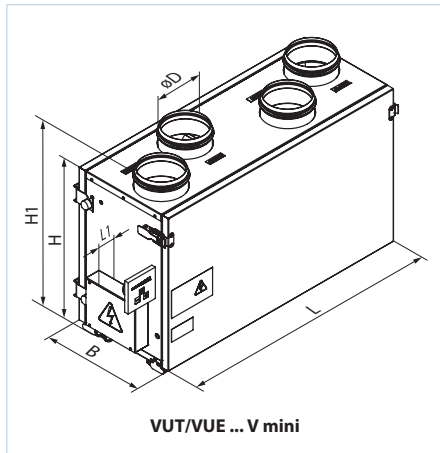



**Technical data**

	VUT 250 V mini VUT 250 H mini	VUE 250 V mini VUE 250 H mini
Unit voltage [V/50 (60) Hz]	1~230	
Power [W]	126	
Current [A]	0.6	
Maximum air flow [m³/h]	260	
Sound pressure level at 3 m distance [dBA]	28-47	
Transported air temperature [°C]	-25...+40	
Insulation	20 mm mineral wool	
Filter: extract	G4	
Filter: supply	G4 (F8 PM2.5 81 % - option)	
Connected air duct diameter [mm]	Ø125	
Heat recovery efficiency* [%]	57-78	52-73
Humidity recovery efficiency* [%]	-	27-45
Heat exchanger type	cross-flow	
Heat exchanger material	polystyrene	enthalpy membrane

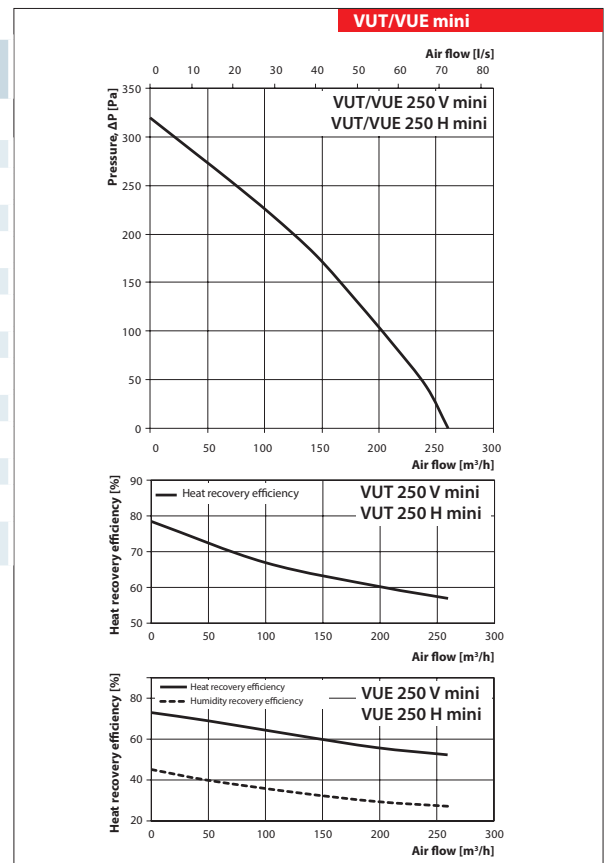
\*Heat recovery efficiency is specified in compliance with EN308 EU.



**Accessories for air handling units**

Model	G4 panel filter	F8 panel filter	Silencers	Back valves	Air dampers
VUT 250 V mini A1					
VUE 250 V mini A1	SF 240x184x40 G4	SF 240x184x40 F8	SR 125	SRF 125	KOM 125
VUT 250 H mini A1					
VUE 250 H mini A1					

Series  
**VENTS VUT/VUE V2 mini EC**



Air handling units with air flow up to **300 m³/h**.  
Heat recovery efficiency up to **79 %**.

■ **Description**

The air handling units are the fully featured ventilation units with heat recovery for air filtration, fresh air supply and stale air extract. During operation the extract air heat is transferred to the supply air stream by the highly efficient plate heat exchanger.

■ **Casing**

The casing of the VUT/VUE 300 V/H mini EC units is of aluzinc steel, internally filled with 20 mm mineral wool heat- and sound-insulating layer.

■ **Fans**

The units are equipped with high-efficient EC motors with an external rotor and forward curved blades.

Series  
**VENTS VUT/VUE H2 mini EC**



Air handling units with air flow up to **300 m³/h**.  
Heat recovery efficiency up to **79 %**.

■ **Heat exchanger**

The **VUT V2/H2 mini EC** units are equipped with a cross-flow polystyrene heat exchanger.

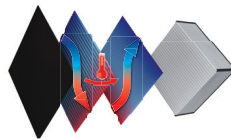

The **VUE V2/H2 mini EC** units are equipped with an enthalpy cross flow heat exchanger.

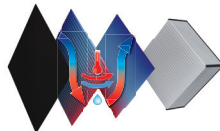

■ **Filter**

Two built-in filters with filtration class G4 and F8 provide efficient supply air filtration. Extract air is cleaned by a built-in filter with filtration class G4.

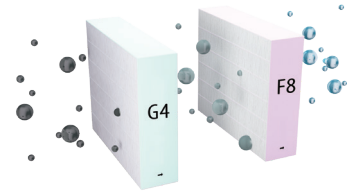

■ **Control and automation**

The VUT/VUE 300 H2/V2 mini EC A2 units are equipped with an A2 speed controller (R-1/010). The VUT/VUE 300 H2/V2 mini EC A14 units are equipped with a remote control panel with touch buttons and LED indication.



To prevent the heat exchanger freezing, electronic protection system is applied. It switches the supply fan off as the temperature sensor requires.



■ **Installation**

Mounting to floor or wall with fixing brackets. The VUE 300 H2 mini EC can also be suspended to the ceiling. The VUT 300 H2 mini EC unit installation position must provide proper condensate drainage.

**Accessories**

Model	Panel filter G4	Panel filter F8	Indoor humidity sensor (0-10 V)	Outdoor CO <sub>2</sub> sensor with indication	Outdoor CO <sub>2</sub> sensor	Outdoor humidity sensor	Kitchen hood
VUT 300 V2/H2 mini EC A2	SF 240x184x40 G4	SF 240x184x40 F8	HV-2	CO2-1	CO2-2	HR-S	KH-1
VUE 300 V2/H2 mini EC A2							
VUT 300 V2/H2 mini EC A14							
VUE 300 V2/H2 mini EC A14							

Model	Silencers		Back valves	Air dampers	Hydraulic U-trap	Electric actuator
	VUT 300 V2/H2 mini EC A2	SR 125	SRF 125	KOM 125	KRV 125	SH-32
VUE 300 V2/H2 mini EC A2						
VUT 300 V2/H2 mini EC A14						
VUE 300 V2/H2 mini EC A14	LF230					

**Designation key**

Series	Rated air flow [m³/h]	Mounting type	Casing type	Model	Motor type	Casing colour	Control type
<b>VUT:</b> ventilation with heat recovery <b>VUE:</b> ventilation with energy recovery	300	<b>V:</b> vertical installation <b>H:</b> horizontal installation	<b>2:</b> 20 mm insulation	<b>mini</b>	<b>EC:</b> synchronous electronically commutated motor	<b>_:</b> aluzinc <b>White:</b> white painted	<b>A2:</b> speed controller <b>A14:</b> sensor control panel with LED indication

**Overall dimensions**

Model	Dimensions [mm]					
	Ø D	B	H	H1	L	L1
VUT 300 V2 mini EC	125	287	447	495	714	776
VUT 300 H2 mini EC				510		810

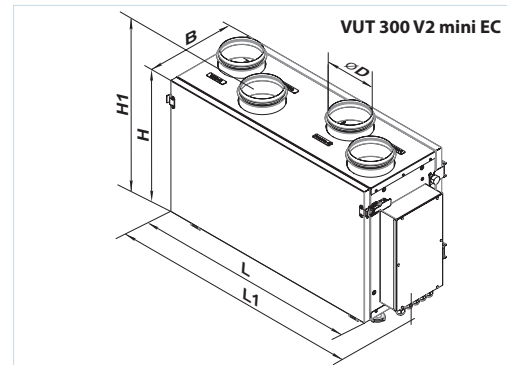
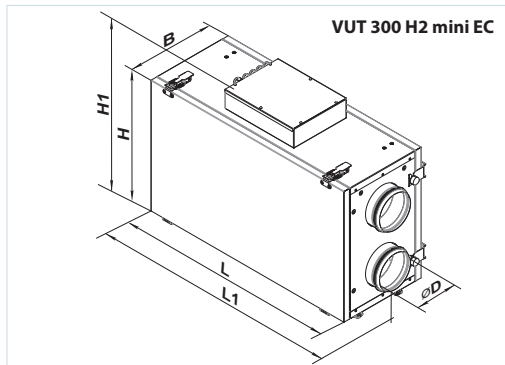

**Technical data**

	VUT 300 V2 mini EC VUT 300 H2 mini EC	VUE 300 V2 mini EC VUE 300 H2 mini EC
Voltage [V/Hz]	1~230	
Maximum unit power (without a heater) [W]	165	
Maximum unit current (without a heater) [A]	1.3	
Max. air flow [m³/h]	300	
Sound pressure level at a distance of 3 m [dBA]	33	
Transported air temperature [°C]	-25...+40	
Insulation	20 mm mineral wool	
Filter: extract filter	G4	
Filter: supply filter	G4, F8 (PM2.5 87%)	
Connected air duct diameter [mm]	Ø125	
Mass [kg]	32	28
Heat recovery efficiency [%]	from 55 up to 79	from 51 up to 73
Humidity recovery efficiency [%]	-	from 26 up to 45
Heat exchanger type	cross-flow	
Heat exchanger material	polystyrene	enthalpy membrane
SEC class (A2)	B	C
SEC class (A14)	A	A

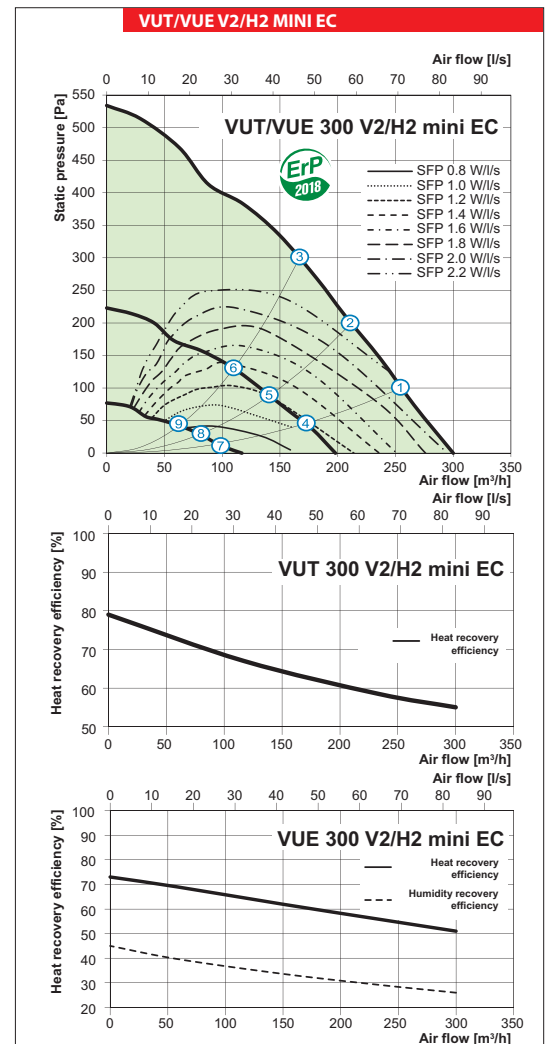

**Application options**

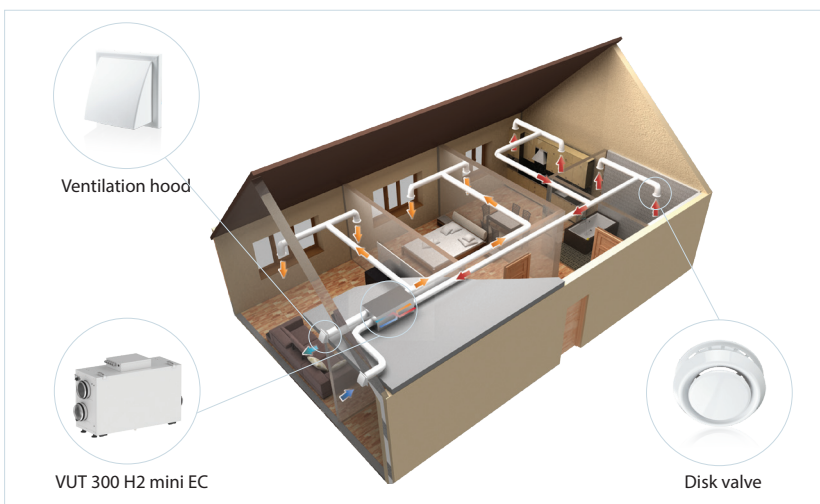

A-weighted sound power level	Gen.	Octave frequency band, Hz								LpA, 3 m	LpA, 1 m	
		63	125	250	500	1000	2000	4000	8000			
L <sub>WA</sub> to supply air inlet	dBA	56	48	43	53	44	44	40	26	24		
L <sub>WA</sub> to supply air outlet	dBA	71	53	53	68	65	60	59	52	51		
L <sub>WA</sub> to exhaust air inlet	dBA	57	43	51	52	52	45	37	26	21		
L <sub>WA</sub> to exhaust air outlet	dBA	72	53	60	66	67	61	62	55	48		
L <sub>WA</sub> surrounding	dBA	53	33	44	47	50	44	38	29	24	33	43

Series  
**VENTS MPA**  
**300-700 E EC A31**

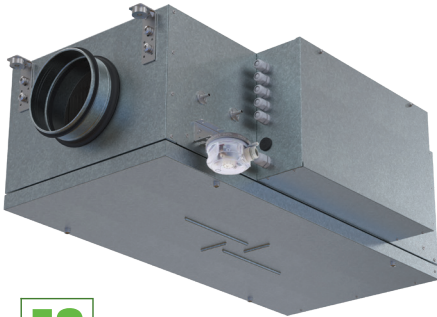

Series  
**VENTS MPA**  
**1000-4000 E EC A31**



Air supply units with the air flow up to **5000 m<sup>3</sup>/h** in the sound- and heat-insulated casing

■ **Description**

Air supply MPA EC unit is a complete ventilation unit for air filtration, air heating and supply to premises.

■ **Casing**

Steel casing covered with aluzinc coating internally filled with 30 mm heat- and sound-insulating layer made of mineral wool.

■ **Filter**

The unit is equipped with a Coarse 60%/G4 filter. An ePM10 90%/F7 class filter is optionally available.

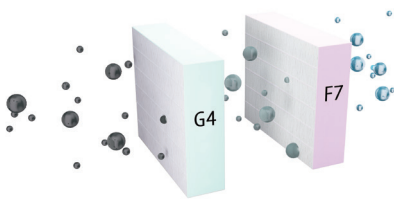

■ **Heater**

Electric heater is used for heating of supply air in cold season.

■ **Fans**

The units are equipped with high-efficient EC-motors with an external rotor and a centrifugal impeller.

■ **Mounting**

The air handling unit is mounted on the floor, suspended to the ceiling or mounted on the wall using brackets.



The unit can be mounted either in service spaces or in main premises (above a false ceiling, in a niche or on a surface).

All electrical connections are made through the terminal block located in the junction box.

It is necessary to provide access to the unit for service and filter cleaning.

■ **Control and automation**

The **MPA E EC** units are equipped with integrated control system. The A31 controller allows integrating the unit into the **Building Management System (BMS)**. Remote control panel is not included in the delivery set and is available as specially ordered accessory.

Functions	A31
	A30
Wired control panel	
	A32
Wired control panel	
Unit on / off	+
Fan speed control and setting	+
Filter clogging indication and control	Pressure sensor
Week schedule	+
Electric heater protection with auto restart	+
Electric heater protection with manual restart	+
Supply temperature control	+
Outer temperature sensor	+
Water heater frost protection	+
Return temperature sensor	+
Air damper control	+
Alarm indication	+
BMS Connection	ModBUS (RTU)
Humidity sensor	0-10 V or NO
CO <sub>2</sub> Sensor	0-10 V or NO
Exhaust fan control	on / off
Three-way valve control	+
Circulation pump control	+
Condensing unit control	0-10 V

**Designation key**

Series	Rated air flow [m <sup>3</sup> /h]	Heater	Heater power [kW]	Motor type	Modification	Controller type
<b>MPA:</b> air handling unit	300; 400; 700; 1000; 1500; 2000; 3000; 4000	<b>E:</b> electric	1.7; 2; 3; 5.1; 6; 9; 12; 14; 15; 18; 24; 27; 45; 54	<b>EC:</b> electronically-commutated motor	<b>L:</b> left <b>R:</b> right	<b>A31</b>

**Design of the MPA 300-700 E EC A31 unit**

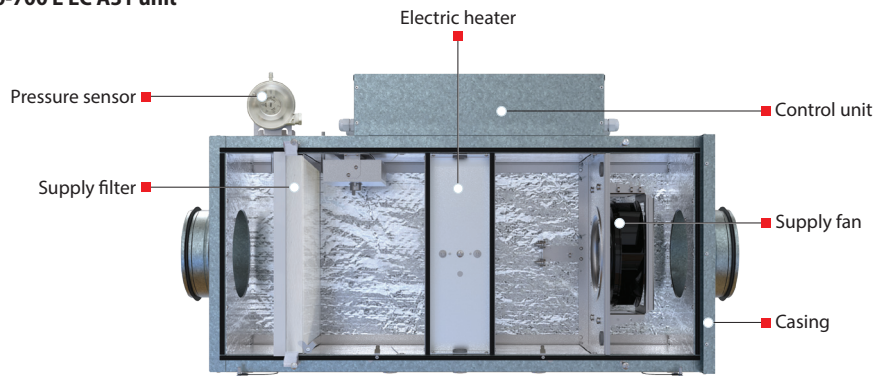

**Design of the MPA 1000-4000 EC A31 unit**

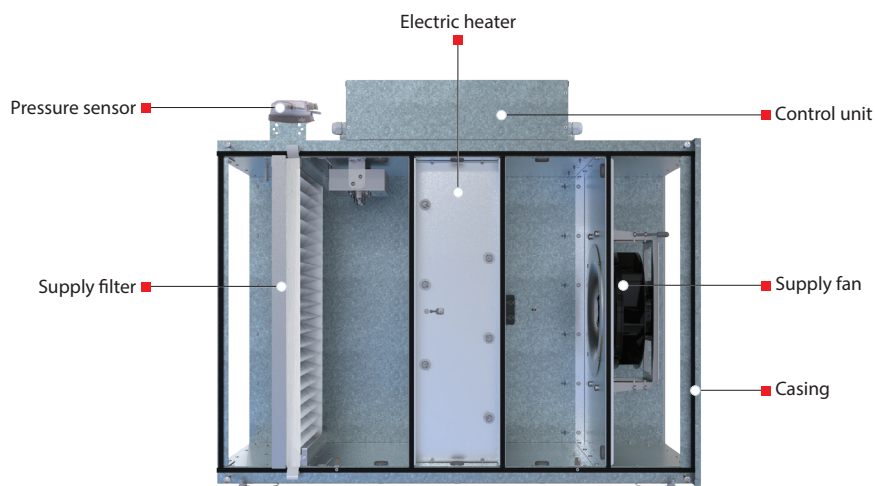

**Overall dimensions**

Model	Dimensions [mm]							
	ØD	L	W	H	L1	L2	W1	W2
MPA 300 E EC A31	160	850	400	290	903	950	514	313
MPA 400 E EC A31	200	850	400	350	903	972	514	313
MPA 700 E EC A31	250	850	460	350	903	972	565	353

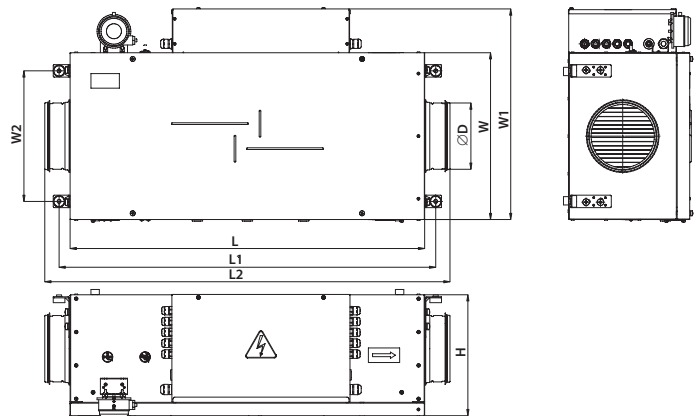

Model	Dimensions [mm]							
	L	W	H	H1	L1	W1	W2	W3
MPA 1000 E EC A31	900	600	380	200	770	653	746	400
MPA 1500 E EC A31	900	700	440	250	770	754	847	500
MPA 2000 E EC A31	900	700	440	300	770	754	847	500
MPA 3000 E EC A31	1200	800	500	300	1070	853	944	600
MPA 4000 E EC A31	1200	940	550	400	1070	993	1087	700

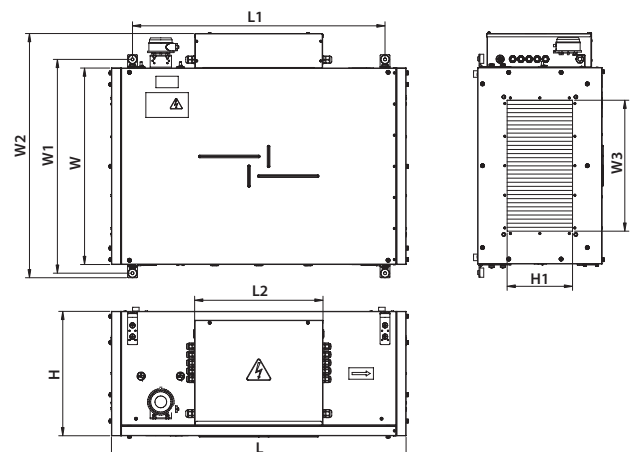

## SUPPLY UNITS

### Technical data

	MPA 300 E-1.7 EC A31	MPA 300 E-5.1 EC A31	MPA 400 E-2.4 EC A31	MPA 400 E-3.3 EC A31	MPA 400 E-6.0 EC A31
Supply voltage [V/50 Hz]	1~230	3~400	1~230	3~400	3~400
Maximum fan power [kW]	0.064	0.064	0.062	0.062	0.062
Maximum electric heater power [kW]	1.7	5.1	2.4	3.3	6.0
Maximum power total [kW]	1.764	5.164	2.462	3.362	6.062
Maximum fan current [A]	0.3	0.3	0.5	0.5	0.5
Maximum current total [A]	7.7	7.4	12	5.4	9.7
Maximum air flow [m <sup>3</sup> /h]	365	354	430	430	430
Sound pressure level through the casing, 3 m, maximum air flow [dBA]	35	35	31	31	31
Transported air temperature [°C]	-30...+40				
Casing material	Aluzinc				
Insulation	30 mm, mineral wool				
Filter	Coarse 90% / G4 (option ePM1 70% / F7)				
Air duct diameter [mm]	160	160	200	200	200
Weight [kg]	24	24	25	25	25

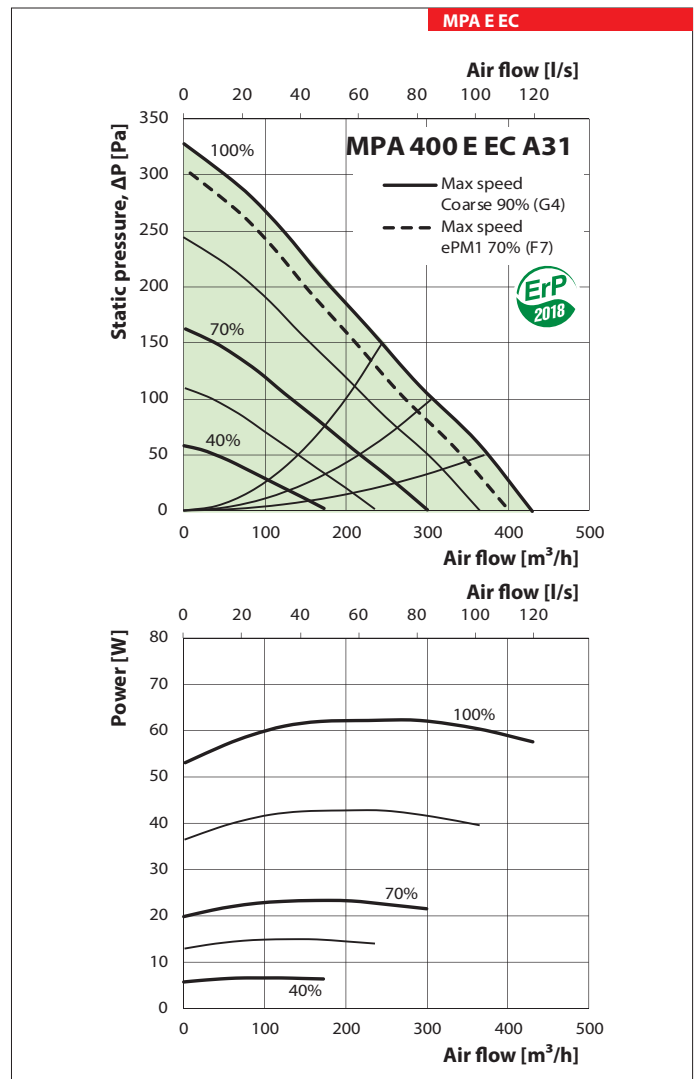
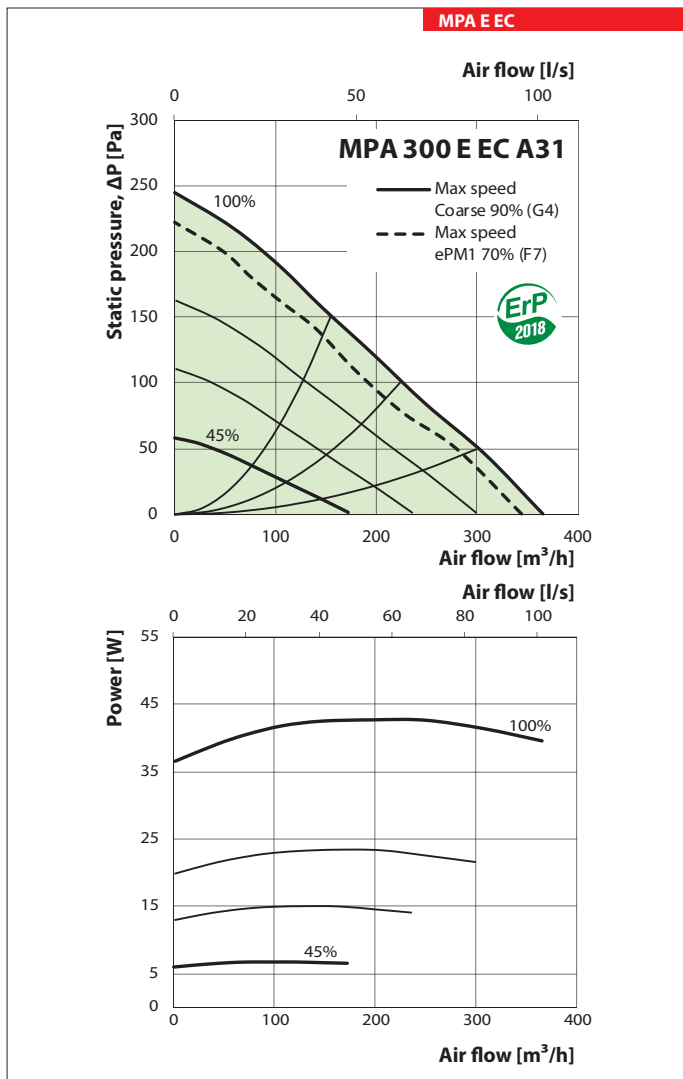

	MPA 700 E-3.0 EC A31	MPA 700 E-6.0 EC A31	MPA 700 E-9.0 EC A31	MPA 1000 E-6.0 EC A31	MPA 1000 E-12.0 EC A31	MPA 1000 E-15.0 EC A31
Supply voltage [V/50 Hz]	3~400	3~400	3~400	3~400	3~400	3~400
Maximum fan power [kW]	0.116	0.116	0.116	0.165	0.165	0.165
Maximum electric heater power [kW]	3.0	6.0	9.0	6.0	12.0	15.0
Maximum power total [kW]	3.116	6.116	9.116	6.165	12.165	15.165
Maximum fan current [A]	0.5	0.5	0.5	1.3	1.3	1.3
Maximum current total [A]	5	10	14.6	11	19.5	24.3
Maximum air flow [m³/h]	760	760	760	1000	1000	1000
Sound pressure level through the casing, 3 m, maximum air flow [dBA]	41	41	41	45	45	45
Transported air temperature [°C]	-30...+40					
Casing material	Aluzinc					
Insulation	30 mm, mineral wool					
Filter	Coarse 90% / G4 (option ePM1 70% / F7)					
Air duct diameter [mm]	250	250	250	400 x 200	400 x 200	400 x 200
Weight [kg]	27	27	27	30	30	30

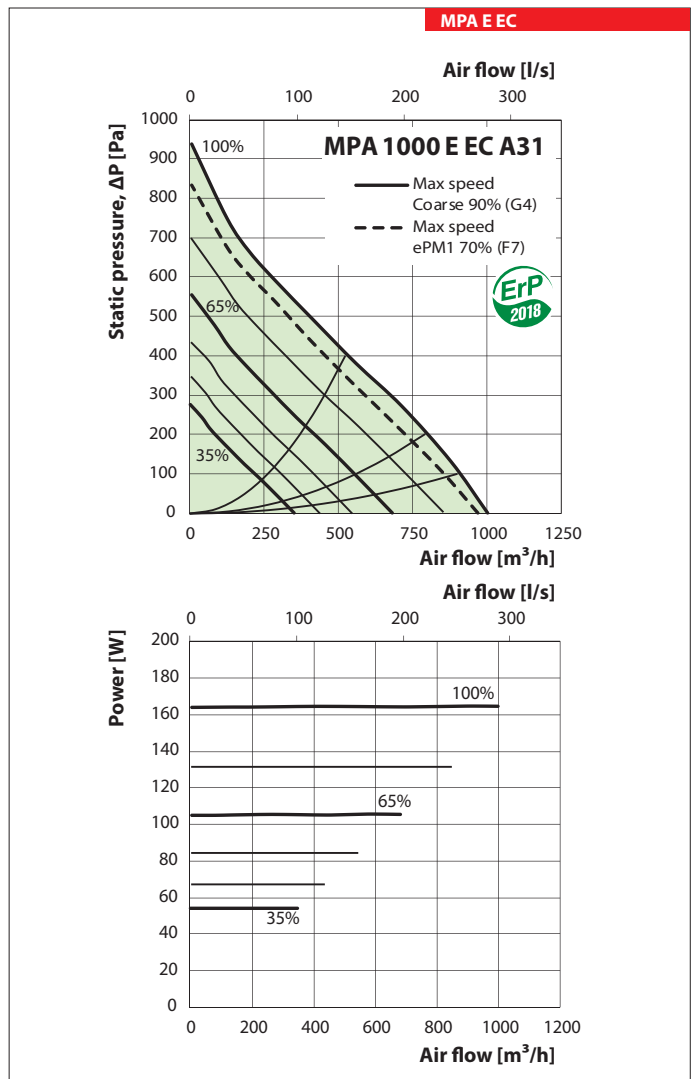
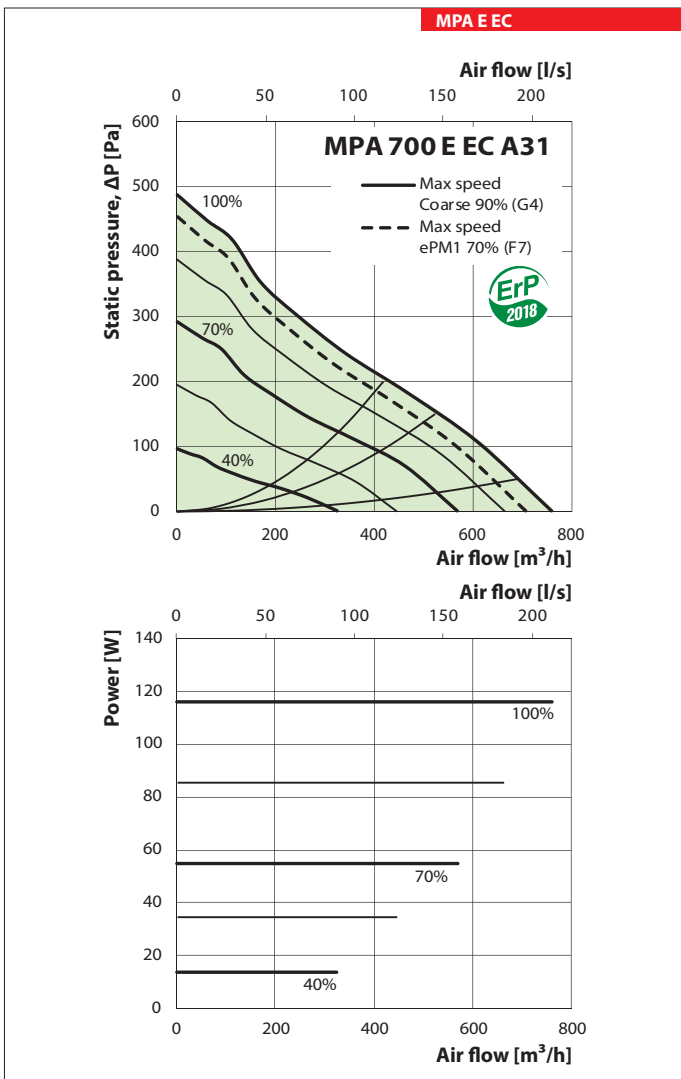

## SUPPLY UNITS

	MPA 1500 E-9.0 EC A31	MPA 1500 E-15.0 EC A31	MPA 1500 E-18.0 EC A31	MPA 2000 E-12.0 EC A31	MPA 2000 E-18.0 EC A31	MPA 2000 E-24.0 EC A31
Supply voltage [V/50 Hz]	3~400	3~400	3~400	3~400	3~400	3~400
Maximum fan power [kW]	0.223	0.223	0.223	0.406	0.406	0.406
Maximum electric heater power [kW]	9.0	15.0	18.0	12.0	18.0	24.0
Maximum power total [kW]	9.223	15.223	18.223	12.406	18.406	24.406
Maximum fan current [A]	1.7	1.7	1.7	1.8	1.8	1.8
Maximum current total [A]	14.8	24.9	29.2	19.9	29.5	39.1
Maximum air flow [m <sup>3</sup> /h]	1500	1500	1500	2450	2450	2450
Sound pressure level through the casing, 3 m, maximum air flow [dBA]	46	46	46	48	48	48
Transported air temperature [°C]	-30...+40					
Casing material	Aluzinc					
Insulation	30 mm, mineral wool					
Filter	Coarse 90% / G4 (option ePM1 70% / F7)					
Air duct diameter [mm]	500 x 250	500 x 250	500 x 250	500 x 300	500 x 300	500 x 300
Weight [kg]	35	35	35	40	40	40

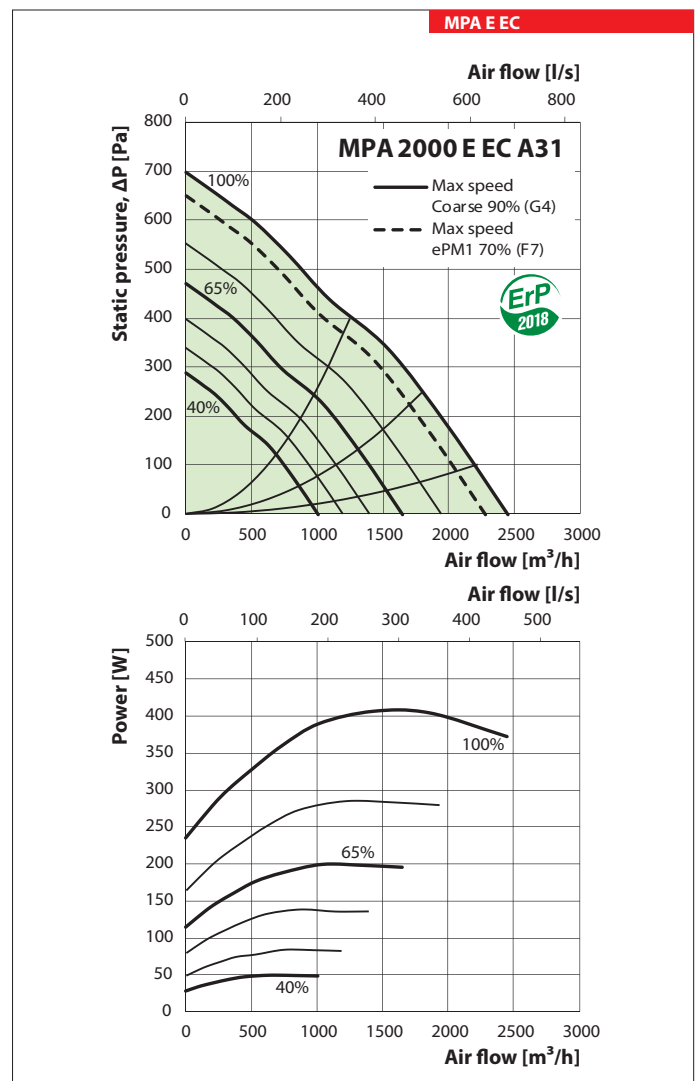
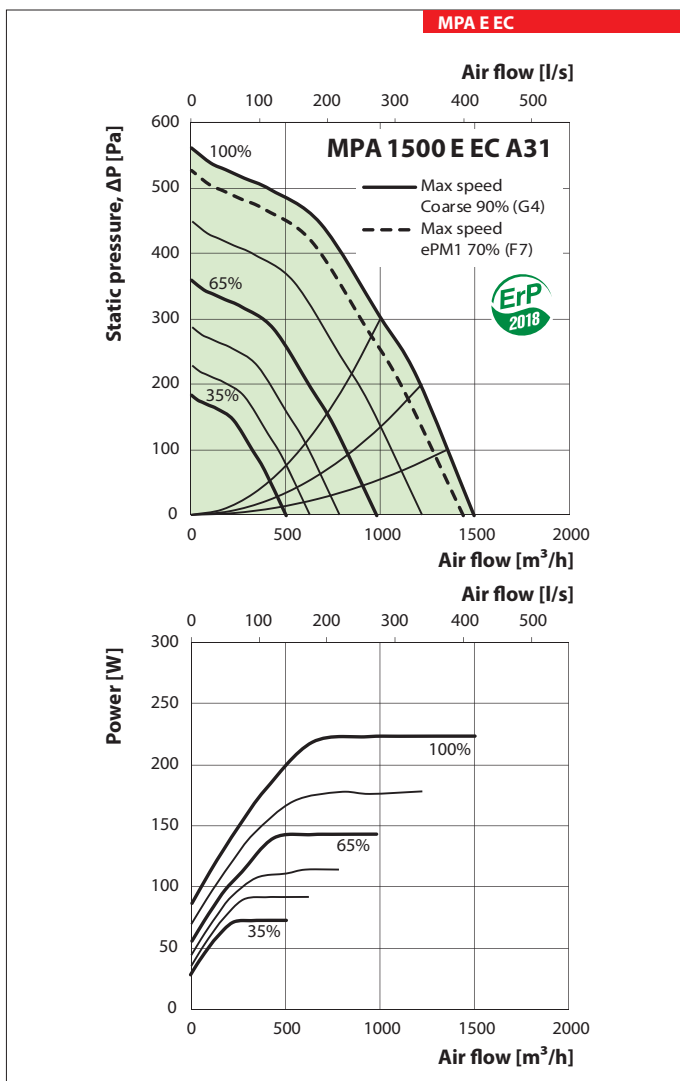

	MPA 3000 E-18.0 EC A31	MPA 3000 E-27.0 EC A31	MPA 3000 E-45.0 EC A31	MPA 4000 E-24.0 EC A31	MPA 4000 E-45.0 EC A31	MPA 4000 E-54.0 EC A31
Supply voltage [V/50 Hz]	3~400	3~400	3~400	3~400	3~400	3~400
Maximum fan power [kW]	0.472	0.472	0.472	0.717	0.717	0.717
Maximum electric heater power [kW]	18.0	27.0	45.0	24.0	45.0	54.0
Maximum power total [kW]	18.472	27.472	45.472	24.717	45.717	54.717
Maximum fan current [A]	2.1	2.1	2.1	1.1	1.1	1.1
Maximum current total [A]	29.6	44	72.8	42.9	73.2	87.6
Maximum air flow [m <sup>3</sup> /h]	3150	3150	3150	5000	5000	5000
Sound pressure level through the casing, 3 m, maximum air flow [dBA]	47	47	47	49	49	49
Transported air temperature [°C]	-30...+40					
Casing material	Aluzinc					
Insulation	30 mm, mineral wool					
Filter	Coarse 90% / G4 (option ePM1 70% / F7)					
Air duct diameter [mm]	600 x 300	600 x 300	600 x 300	700 x 400	700 x 400	700 x 400
Weight [kg]	50	50	50	60	60	60

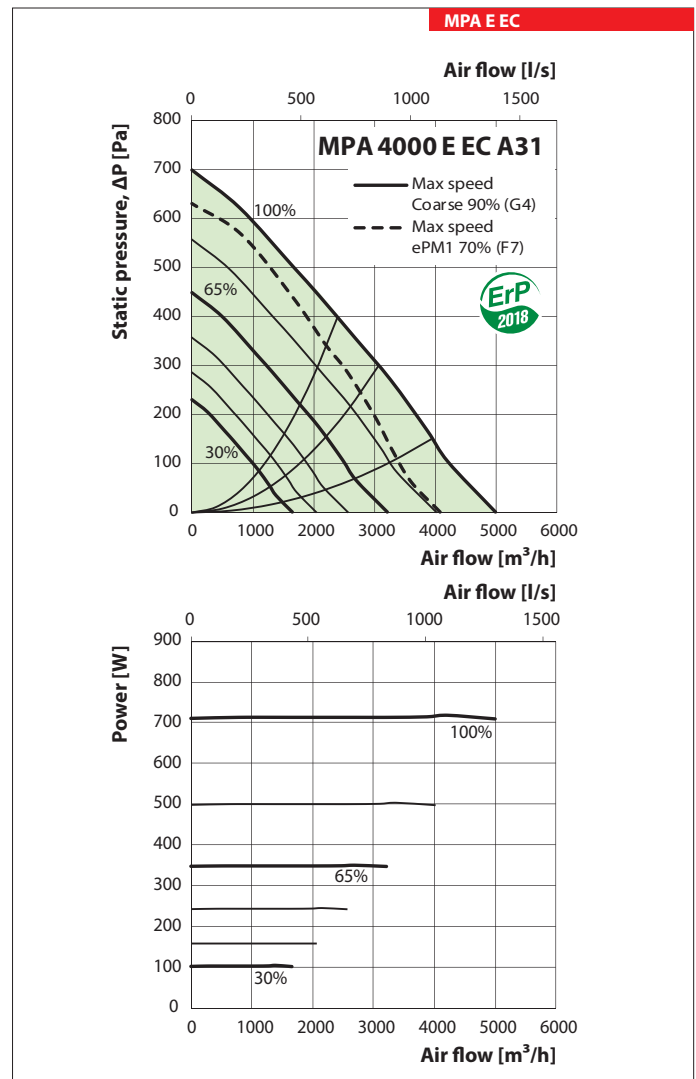
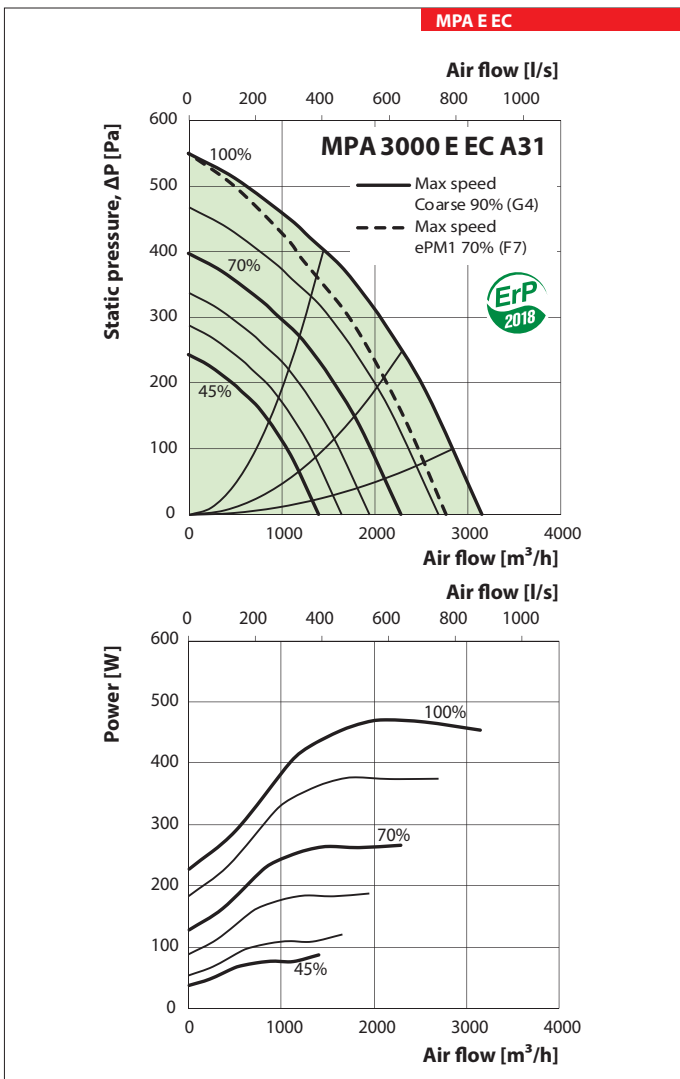

## SUPPLY UNITS

### Accessories for air handling units

Model	Filter Coarse/G4	Filter ePM1/F7	Flexible connector	Silencer	Air Damper	Electric actuator	
							
MPA 300 E EC A31	SF 334x226x48 Coarse 90% / G4	SF 334x226x48 ePM1 70% / F7	VVG 160	SR 160	KRV 160	TF230	TF24
MPA 400 E EC A31	SF 334x287x48 Coarse 90% / G4	SF 334x287x48 ePM1 70% / F7	VVG 200	SR 200	KRV 200		
MPA 700 E EC A31	SF 384x287x48 Coarse 90% / G4	SF 384x287x48 ePM1 70% / F7	VVG 250	SR 250	KRV 250		
MPA 1000 E EC A31	SF 536x316x48 Coarse 90% / G4	SF 536x316x48 ePM1 70% / F7	VVG 400x200	SR 400x200	RRV 400x200		
MPA 1500 E EC A31	SF 636x376x48 Coarse 90% / G4	SF 636x376x48 ePM1 70% / F7	VVG 500x250	SR 500x250	RRV 500x250		
MPA 2000 E EC A31	SF 636x376x48 Coarse 90% / G4	SF 636x376x48 ePM1 70% / F7	VVG 500x300	SR 500x300	RRV 500x300		
MPA 3000 E EC A31	SF 734x435x80 Coarse 90% / G4	SF 734x435x80 ePM1 70% / F7	VVG 600x300	SR 600x300	RRV 600x300		
MPA 4000 E EC A31	SF 874x485x80 Coarse 90% / G4	SF 874x485x80 ePM1 70% / F7	VVG 700x400	SR 700x400	RRV 700x400		



Series  
**VENTS MPA  
700 W EC A31**

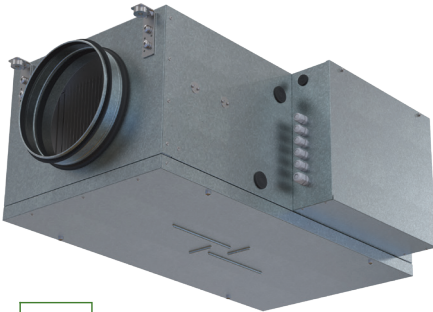

Series  
**VENTS MPA  
1000-4000 W EC A31**

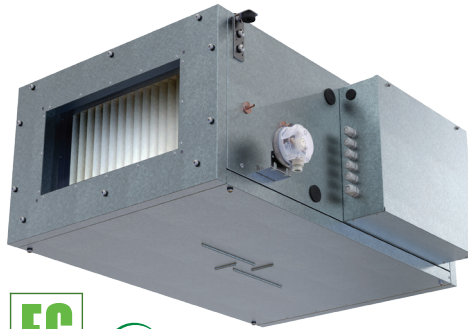

Air supply units with the air flow up to **4950 m<sup>3</sup>/h** in the sound- and heat-insulated casing

■ **Description**

Air supply MPA EC unit is a complete ventilation unit for air filtration, air heating and supply to premises.

■ **Casing**

Steel casing covered with aluzinc coating internally filled with 30 mm heat- and sound-insulating layer made of mineral wool.

■ **Filter**

The unit is equipped with a Coarse 60%/G4 filter. An ePM10 90%/F7 class filter is optionally available.

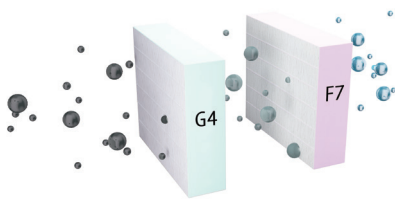

■ **Heater**

Water heater is used for heating of supply air in cold season.

■ **Fans**

The units are equipped with high-efficient EC-motors with an external rotor and a centrifugal impeller.

■ **Mounting**

The air handling unit is mounted on the floor, suspended to the ceiling or mounted on the wall using brackets.



The unit can be mounted either in service spaces or in main premises (above a false ceiling, in a niche or on a surface).

All electrical connections are made through the terminal block located in the junction box.

It is necessary to provide access to the unit for service and filter cleaning.

■ **Control and automation**

The **MPA W EC** units are equipped with integrated control system. The A31 controller allows integrating the unit into the **Building Management System (BMS)**. Remote control panel is not included in the delivery set and is available as specially ordered accessory.

Functions	A31
	A30
Wired control panel	
	A32
Wired control panel	
Unit on / off	+
Fan speed control and setting	+
Filter clogging indication and control	Pressure sensor
Week schedule	+
Electric heater protection with auto restart	+
Electric heater protection with manual restart	+
Supply temperature control	+
Outer temperature sensor	+
Water heater frost protection	+
Return temperature sensor	+
Air damper control	+
Alarm indication	+
BMS Connection	ModBUS (RTU)
Humidity sensor	0-10 V or NO
CO <sub>2</sub> Sensor	0-10 V or NO
Exhaust fan control	on / off
Three-way valve control	+
Circulation pump control	+
Condensing unit control	0-10 V

**Designation key**

Series	Rated air flow [m <sup>3</sup> /h]	Heater	Motor type	Modification	Controller type
<b>MPA:</b> air handling unit	700; 1000; 1500; 2000; 3000; 4000	<b>W:</b> water	<b>EC:</b> electronically-commutated motor	<b>L:</b> left <b>R:</b> right	<b>A31</b>

**Design of the MPA 700 W EC A31 unit**

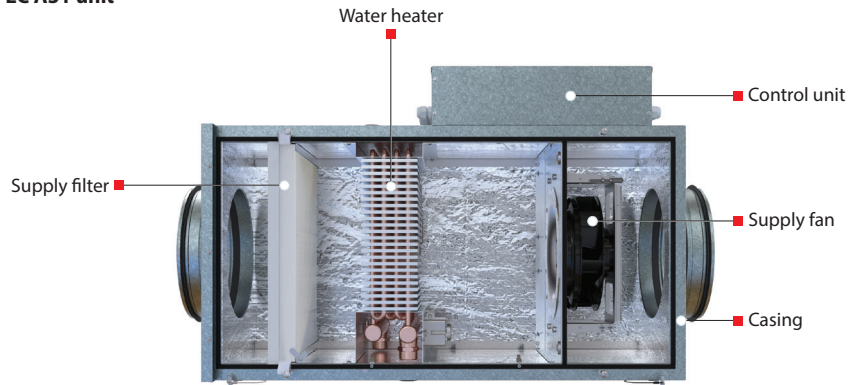

**Design of the MPA 1000-4000 EC A31 unit**

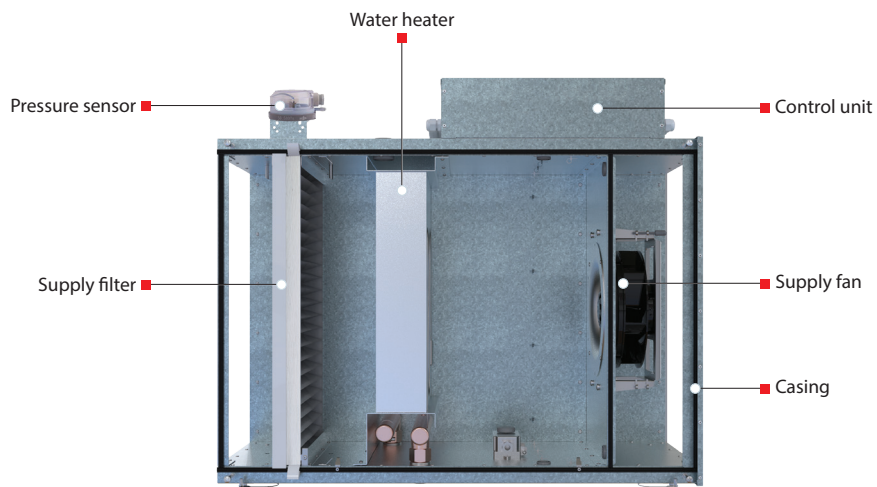

**Overall dimensions**

Model	Dimensions [mm]								
	ØD	L	W	H	L1	L2	L3	W1	H1
MPA 700 W EC A31	250	850	460	350	903	972	65	565	218

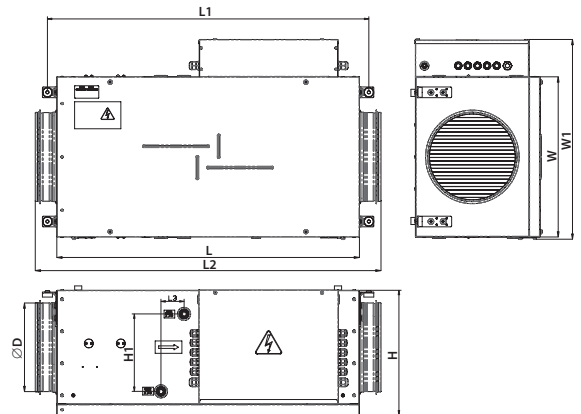

Model	Dimensions [mm]									
	L	W	H	L1	L2	W1	W2	W3	H1	H2
MPA 1000 W EC A31	900	600	380	770	65	653	746	400	200	250
MPA 1500 W EC A31	900	700	440	770	65	754	847	500	250	318
MPA 2000 W EC A31	900	700	440	770	65	754	847	500	300	318
MPA 3000 W EC A31	1200	800	500	1070	65	853	944	600	300	368
MPA 4000 W EC A31	1200	940	550	1070	65	993	1087	700	400	380

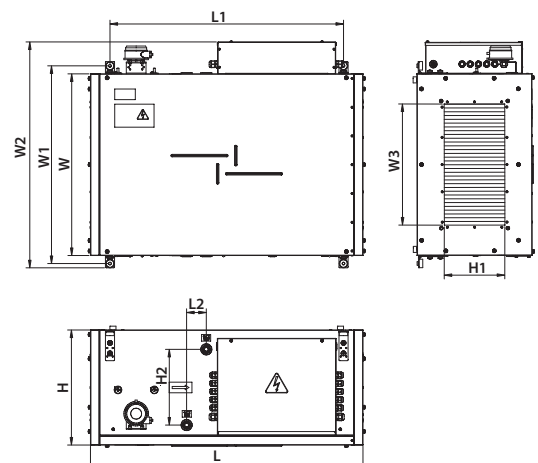

## SUPPLY UNITS

### Technical data

	MPA 700 W EC A31	MPA 1000 W EC A31
Supply voltage [V/50 Hz]	1~230	
The number of water heater rows	4	
Connection diameter of the heat exchanger [in]	3/4	1
Maximum fan power [kW]	0.139	0.165
Maximum fan current [A]	1.05	1.23
Maximum air flow [m <sup>3</sup> /h]	800	920
Maximum water temperature [°C]	150	150
Sound pressure level through the casing at a distance 3 m [dBA]	44	48
Transported air temperature [°C]	-30...+40	
Casing material	Aluzinc	
Insulation	30 mm, mineral wool	
Filter	Coarce 90% / G4 (option ePM1 70% / F7)	
Air duct connection dimensions [mm]	250	400 x 200
Weight [kg]	27	35

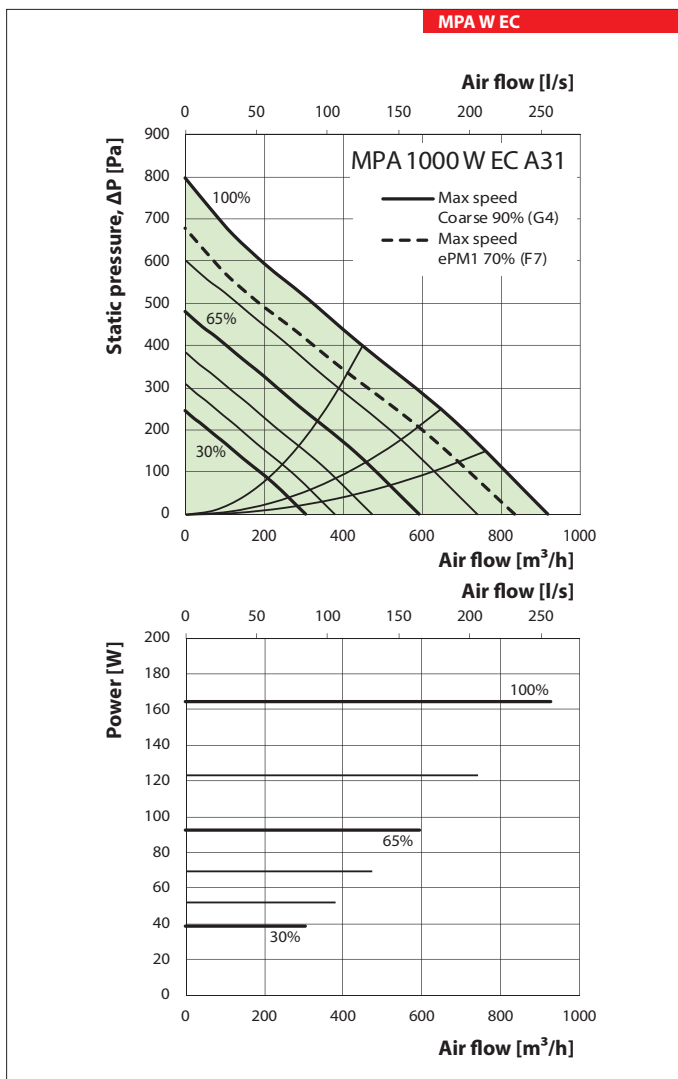
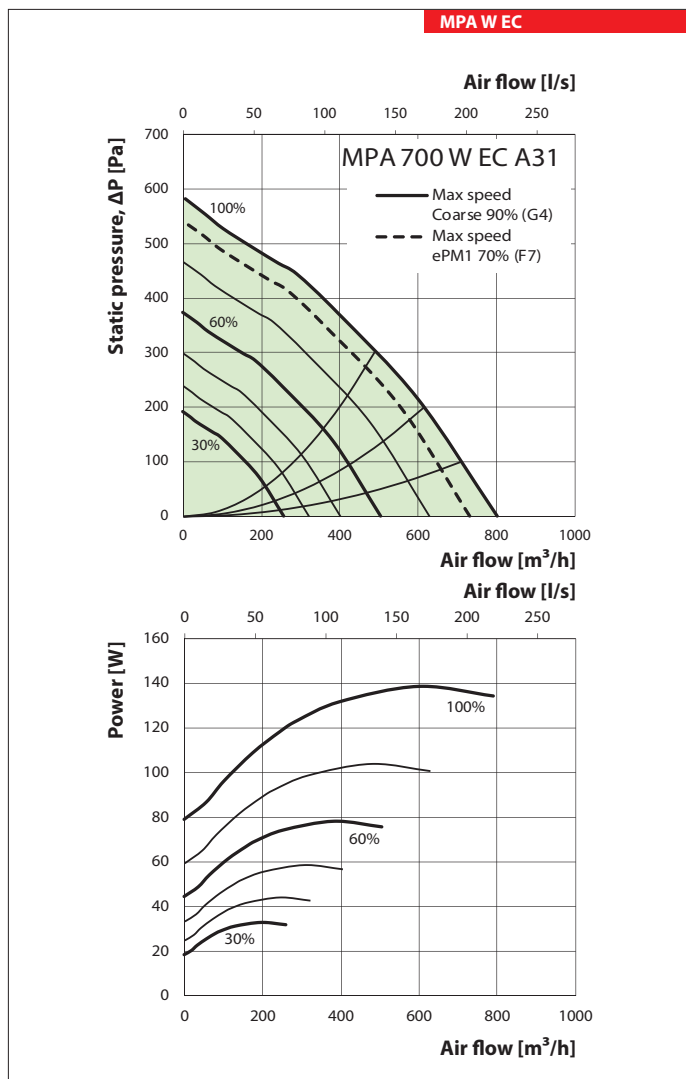

	MPA 1500 W EC A31	MPA 2000 W EC A31
Supply voltage [V/50 Hz]	1~230	1~230
The number of water heater rows	4	4
Connection diameter of the heat exchanger [in]	1	1
Maximum fan power [kW]	0.222	0.387
Maximum fan current [A]	1.6	1.7
Maximum air flow [m <sup>3</sup> /h]	1445	2150
Maximum water temperature [°C]	150	150
Sound pressure level through the casing at a distance 3 m [dBA]	49	53
Transported air temperature [°C]	-30...+40	
Casing material	Aluzinc	
Insulation	30 mm, mineral wool	
Filter	Coarse 90% / G4 (option ePM1 70% / F7)	
Air duct connection dimensions [mm]	500 x 250	500 x 300
Weight [kg]	49	45

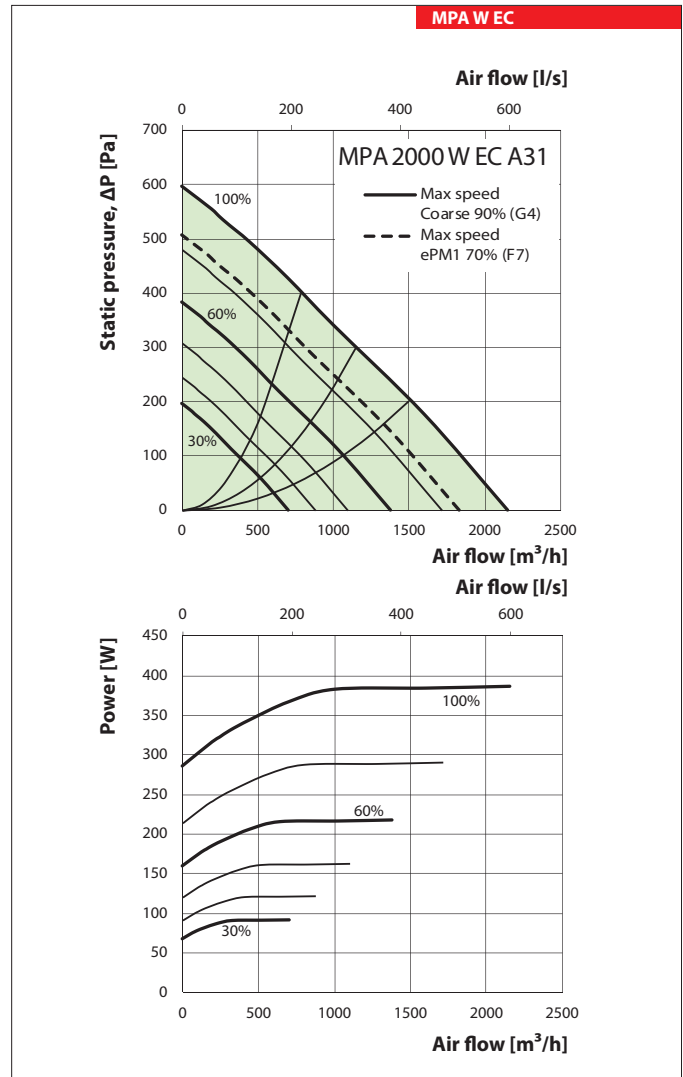
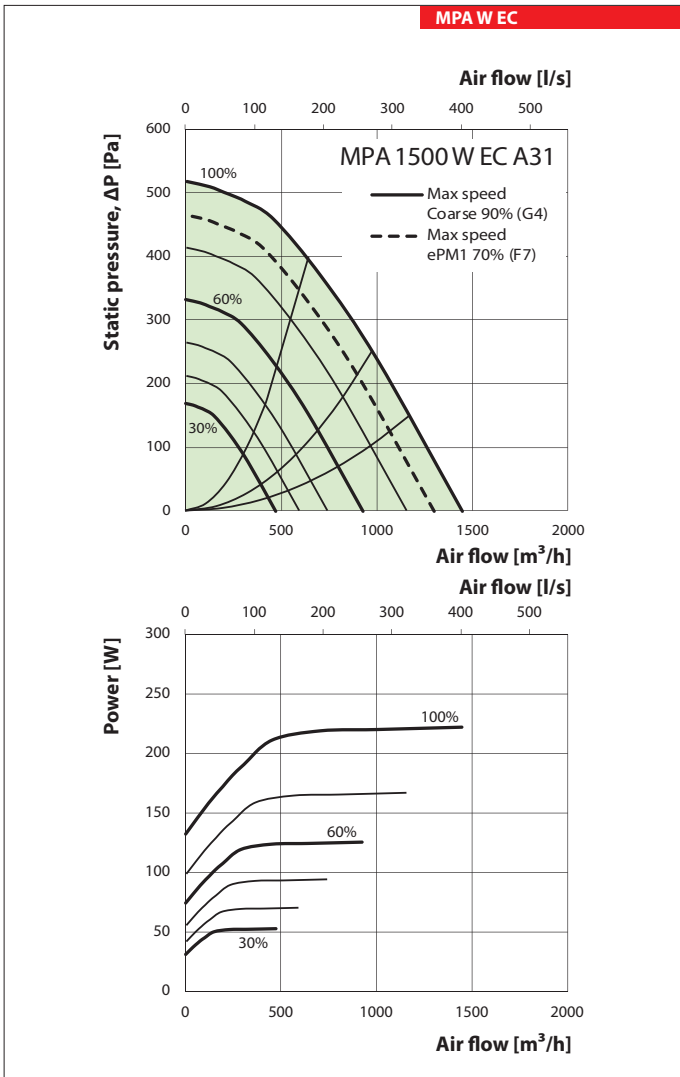

Technical data

	MPA 3000 W EC A31	MPA 4000 W EC A31
Supply voltage [V/50 Hz]	1~230	1~230
The number of water heater rows	4	4
Connection diameter of the heat exchanger [in]	1 1/4	1 3/8
Maximum fan power [kW]	0.425	0.698
Maximum fan current [A]	1.8	1.06
Maximum air flow [m <sup>3</sup> /h]	2930	4950
Maximum water temperature [°C]	150	150
Sound pressure level through the casing at a distance 3 m [dBA]	52	54
Transported air temperature [°C]	-30...+40	
Casing material	Aluzinc	
Insulation	30 mm, mineral wool	
Filter	Coarce 90% / G4 (option ePM1 70% / F7)	
Air duct connection dimensions [mm]	600 x 300	700 x 400
Weight [kg]	50	58

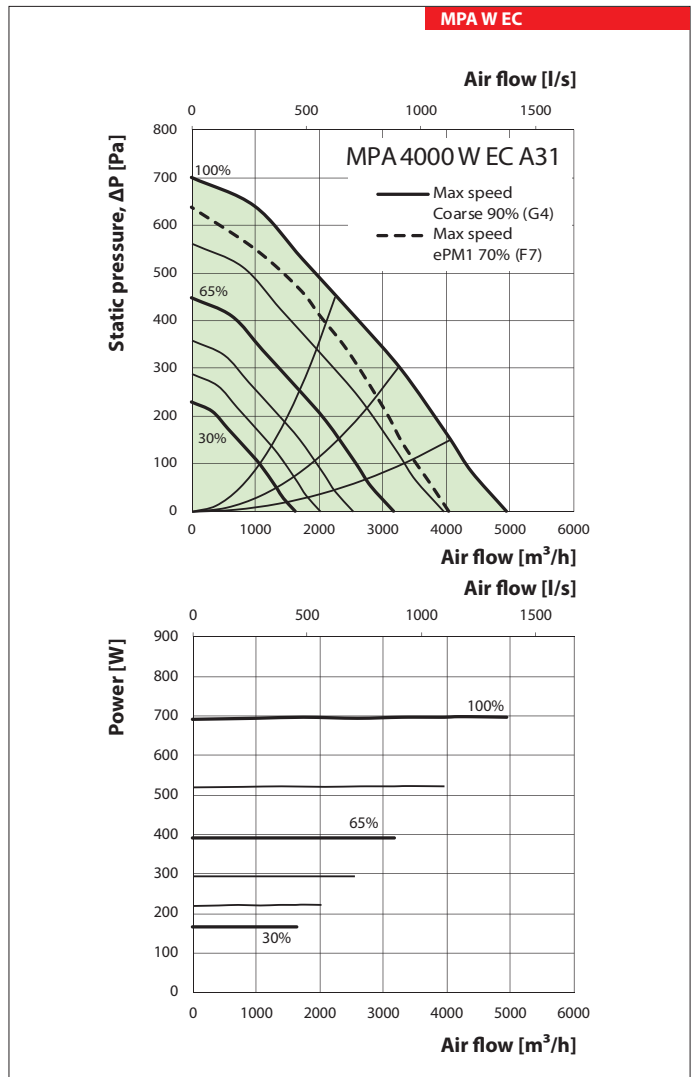
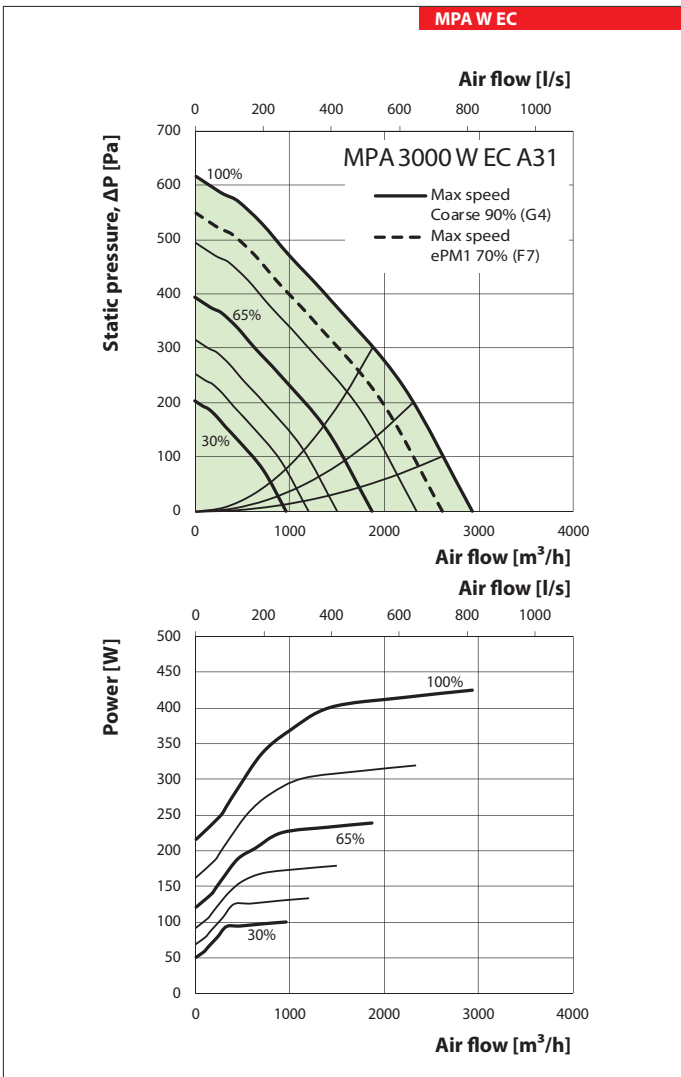

**Accessories for air handling units**

Model	Filter Coarce/G4	Filter ePM1/F7	Flexible connector	Silencer	Air Damper	Electric actuator	
							
MPA 700 W EC A31	SF 384x287x48 Coarse 90% / G4	SF 384x287x48 ePM1 70% / F7	VVG 250	SR 250	KRV 250	TF230	TF24
MPA 1000 W EC A31	SF 536x316x48 Coarse 90% / G4	SF 536x316x48 ePM1 70% / F7	VVG 400x200	SR 400x200	RRV 400x200		
MPA 1500 W EC A31	SF 636x376x48 Coarse 90% / G4	SF 636x376x48 ePM1 70% / F7	VVG 500x250	SR 500x250	RRV 500x250		
MPA 2000 W EC A31	SF 636x376x48 Coarse 90% / G4	SF 636x376x48 ePM1 70% / F7	VVG 500x300	SR 500x300	RRV 500x300		
MPA 3000 W EC A31	SF 734x435x80 Coarse 90% / G4	SF 734x435x80 ePM1 70% / F7	VVG 600x300	SR 600x300	RRV 600x300		
MPA 4000 W EC A31	SF 874x485x80 Coarse 90% / G4	SF 874x485x80 ePM1 70% / F7	VVG 700x400	SR 700x400	RRV 700x400		

**Hot water coil parameters MPA 700 W EC A31**

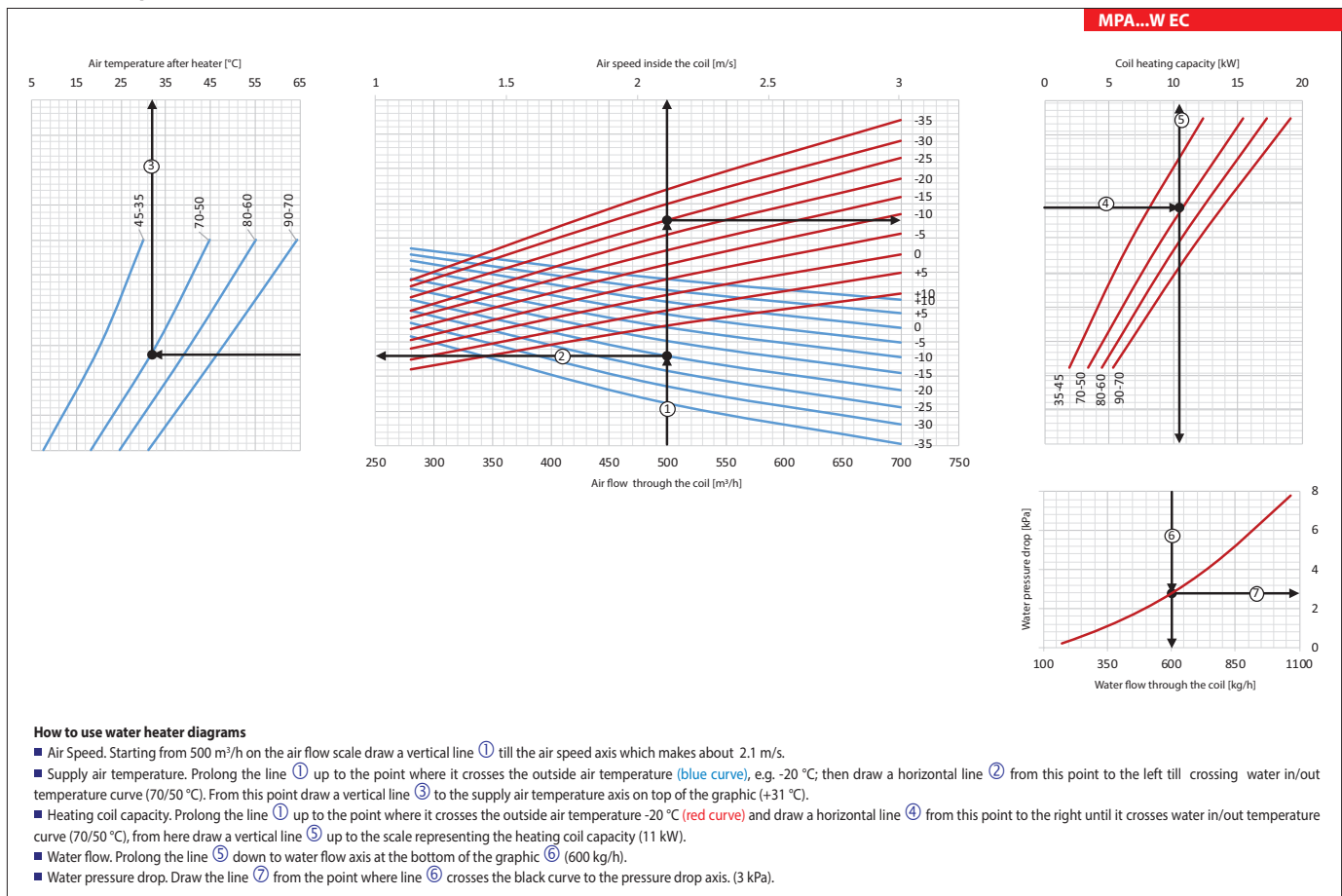

Hot water coil parameters MPA 1000 W EC A31

MPA...W EC

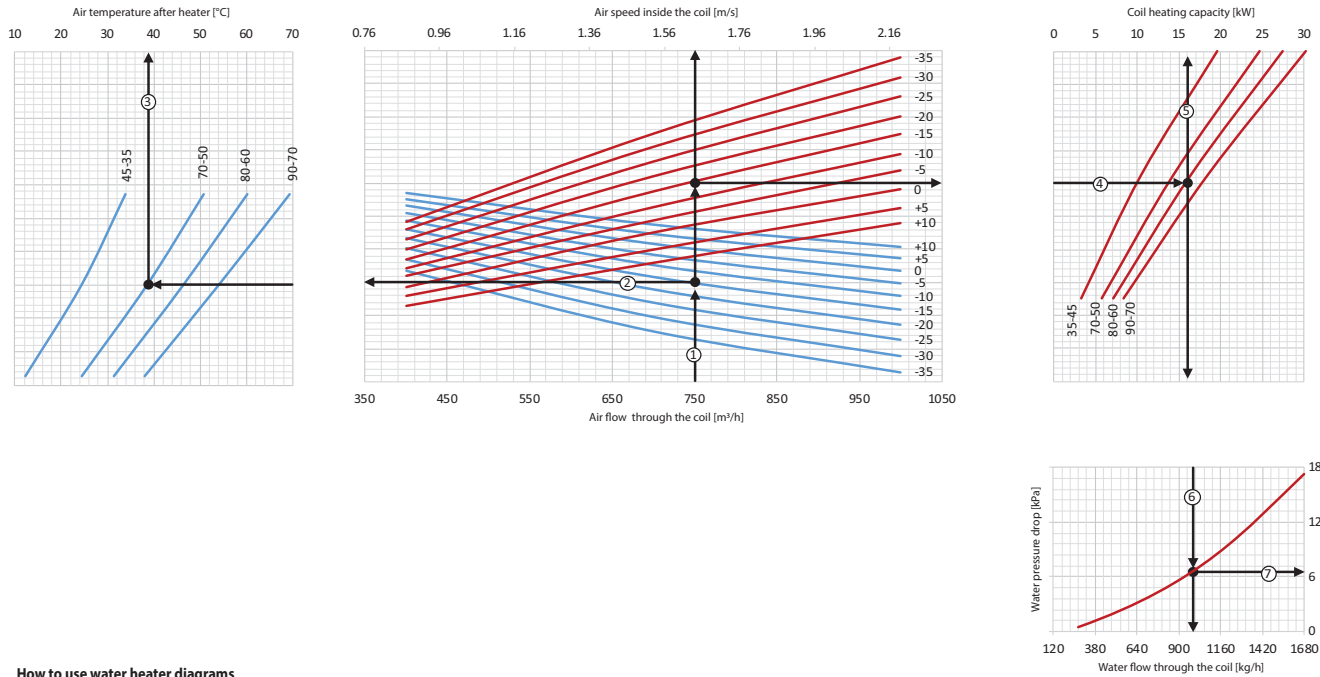

How to use water heater diagrams

- Air Speed. Starting from 750 m³/h on the air flow scale draw a vertical line ① till the air speed axis which makes about 1.6 m/s.
- Supply air temperature. Prolong the line ① up to the point where it crosses the outside air temperature (blue curve), e.g. -15 °C; then draw a horizontal line ② from this point to the left till crossing water in/out temperature curve (70/50 °C). From this point draw a vertical line ③ to the supply air temperature axis on top of the graphic (+39 °C).
- Heating coil capacity. Prolong the line ① up to the point where it crosses the outside air temperature -15 °C (red curve) and draw a horizontal line ④ from this point to the right until it crosses water in/out temperature curve (70/50 °C), from here draw a vertical line ⑤ up to the scale representing the heating coil capacity (16 kW).
- Water flow. Prolong the line ⑤ down to water flow axis at the bottom of the graphic ⑥ (1000 kg/h).
- Water pressure drop. Draw the line ⑦ from the point where line ⑥ crosses the black curve to the pressure drop axis. (6 kPa).

Hot water coil parameters MPA 1500 W EC A31

MPA...W EC

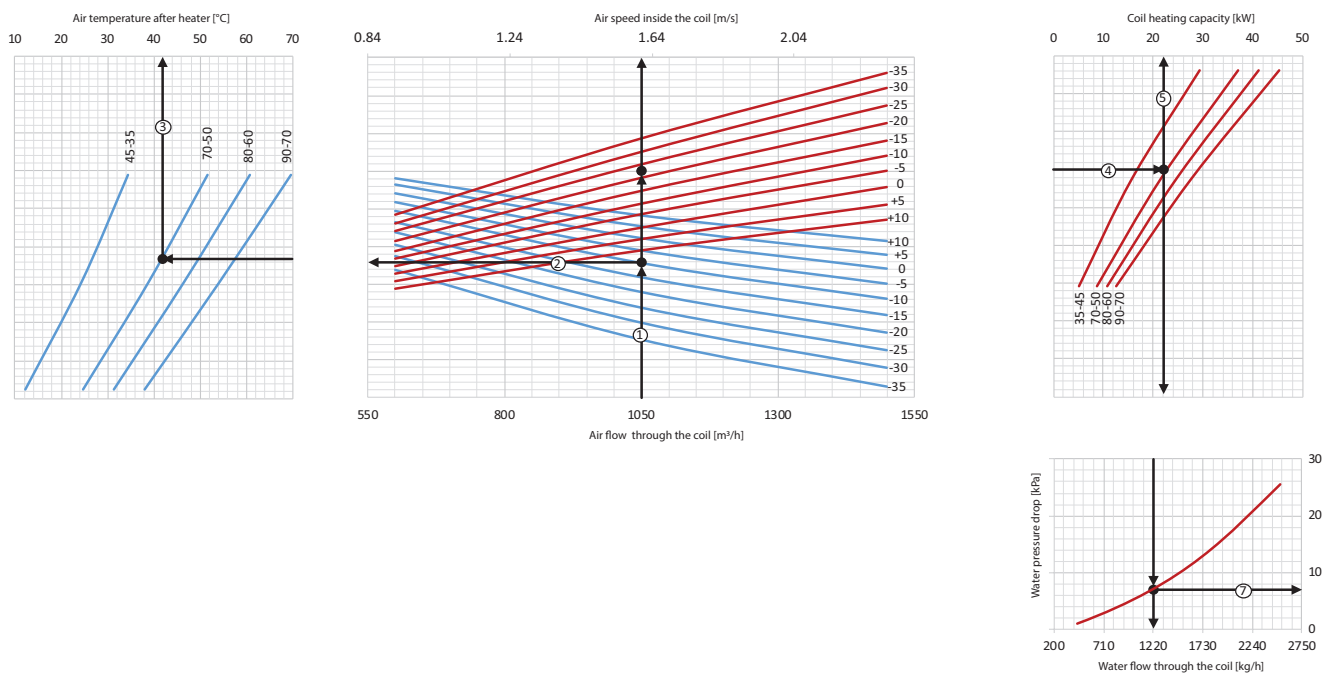

How to use water heater diagrams

- Air Speed. Starting from 1050 m³/h on the air flow scale draw a vertical line ① till the air speed axis which makes about 1.6 m/s.
- Supply air temperature. Prolong the line ① up to the point where it crosses the outside air temperature (blue curve), e.g. -10 °C; then draw a horizontal line ② from this point to the left till crossing water in/out temperature curve (70/50 °C). From this point draw a vertical line ③ to the supply air temperature axis on top of the graphic (+41 °C).
- Heating coil capacity. Prolong the line ① up to the point where it crosses the outside air temperature -15 °C (red curve) and draw a horizontal line ④ from this point to the right until it crosses water in/out temperature curve (70/50 °C), from here draw a vertical line ⑤ up to the scale representing the heating coil capacity (22 kW).
- Water flow. Prolong the line ⑤ down to water flow axis at the bottom of the graphic ⑥ (1220 kg/h).
- Water pressure drop. Draw the line ⑦ from the point where line ⑥ crosses the black curve to the pressure drop axis. (8.5 kPa).

### Hot water coil parameters MPA 2000 W EC A31

MPA...W EC

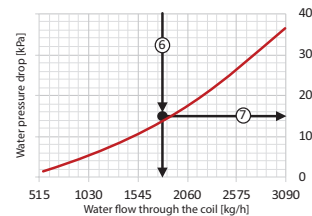
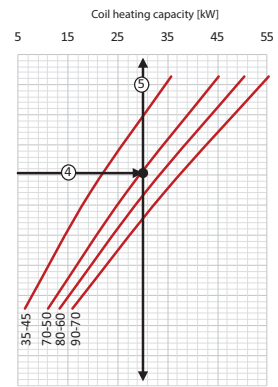
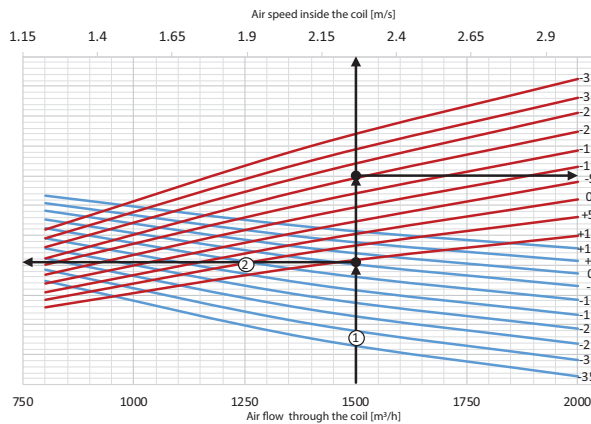
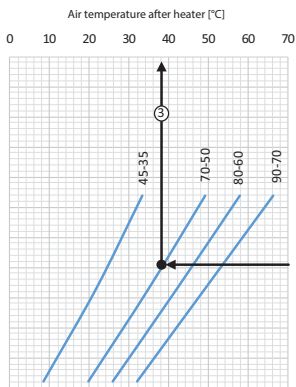

#### How to use water heater diagrams

- Air Speed. Starting from 1500 m<sup>3</sup>/h on the air flow scale draw a vertical line ① till the air speed axis which makes about 2.25 m/s.
- Supply air temperature. Prolong the line ① up to the point where it crosses the outside air temperature (blue curve), e.g. -5 °C; then draw a horizontal line ② from this point to the left till crossing water in/out temperature curve (70/50 °C). From this point draw a vertical line ③ to the supply air temperature axis on top of the graphic (+38 °C).
- Heating coil capacity. Prolong the line ① up to the point where it crosses the outside air temperature -15 °C (red curve) and draw a horizontal line ④ from this point to the right until it crosses water in/out temperature curve (70/50 °C), from here draw a vertical line ⑤ up to the scale representing the heating coil capacity (30 kW).
- Water flow. Prolong the line ⑤ down to water flow axis at the bottom of the graphic ⑥ (1750 kg/h).
- Water pressure drop. Draw the line ⑦ from the point where line ⑥ crosses the black curve to the pressure drop axis. (15 kPa).

### Hot water coil parameters MPA 3000 W EC A31

MPA...W EC

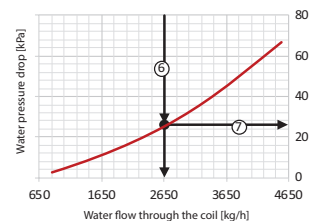
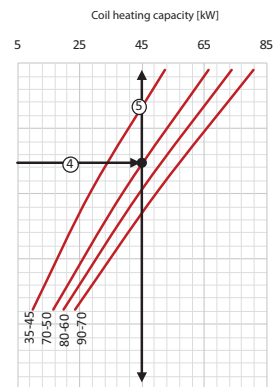
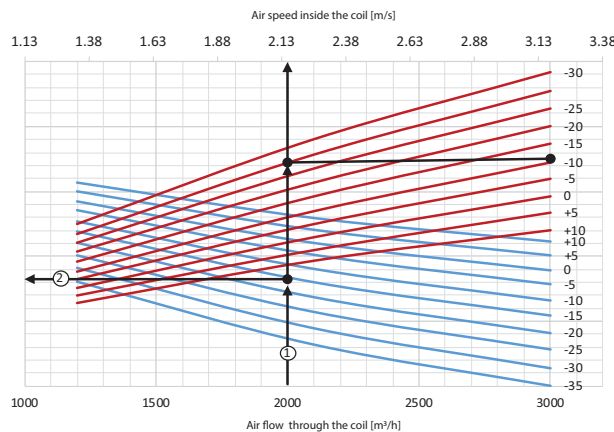
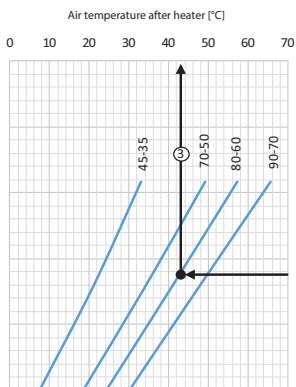

#### How to use water heater diagrams

- Air Speed. Starting from 2000 m<sup>3</sup>/h on the air flow scale draw a vertical line ① till the air speed axis which makes about 2.2 m/s.
- Supply air temperature. Prolong the line ① up to the point where it crosses the outside air temperature (blue curve), e.g. -15 °C; then draw a horizontal line ② from this point to the left till crossing water in/out temperature curve (80/60 °C). From this point draw a vertical line ③ to the supply air temperature axis on top of the graphic (+43 °C).
- Heating coil capacity. Prolong the line ① up to the point where it crosses the outside air temperature -15 °C (red curve) and draw a horizontal line ④ from this point to the right until it crosses water in/out temperature curve (70/50 °C), from here draw a vertical line ⑤ up to the scale representing the heating coil capacity (45 kW).
- Water flow. Prolong the line ⑤ down to water flow axis at the bottom of the graphic ⑥ (2650 kg/h).
- Water pressure drop. Draw the line ⑦ from the point where line ⑥ crosses the black curve to the pressure drop axis. (24 kPa).

Hot water coil parameters MPA 4000 W EC A31

MPA...W EC

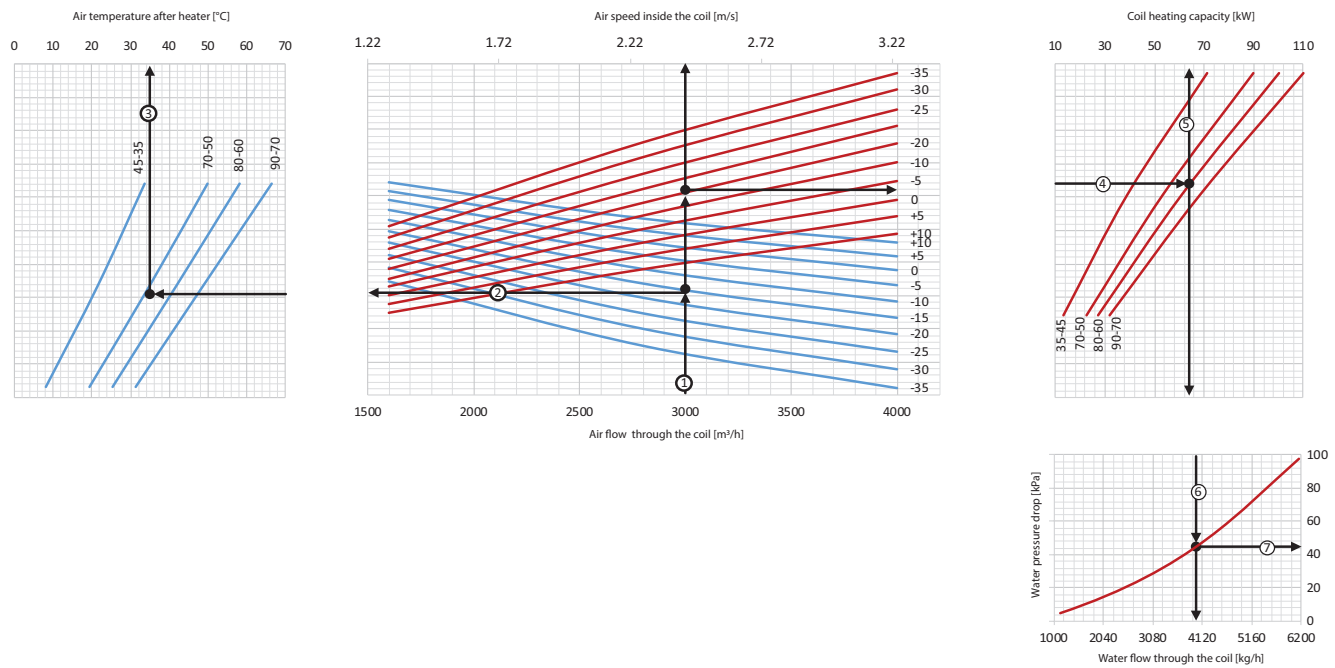

How to use water heater diagrams

- Air Speed. Starting from 3000 m³/h on the air flow scale draw a vertical line ① till the air speed axis which makes about 2.5 m/s.
- Supply air temperature. Prolong the line ① up to the point where it crosses the outside air temperature (blue curve), e.g. -15 °C; then draw a horizontal line ② from this point to the left till crossing water in/out temperature curve (70/50 °C). From this point draw a vertical line ③ to the supply air temperature axis on top of the graphic (+35 °C).
- Heating coil capacity. Prolong the line ① up to the point where it crosses the outside air temperature -20 °C (red curve) and draw a horizontal line ④ from this point to the right until it crosses water in/out temperature curve (80/60 °C), from here draw a vertical line ⑤ up to the scale representing the heating coil capacity (65 kW).
- Water flow. Prolong the line ⑤ down to water flow axis at the bottom of the graphic ⑥ (4100 kg/h).
- Water pressure drop. Draw the line ⑦ from the point where line ⑥ crosses the black curve to the pressure drop axis. (45 kPa).



Series  
**SR**



Series  
**SRF**



■ **Applications**

Silencer is applied for noise absorption produced during the ventilating equipment operation and spread along the ducting systems. Suitable for installation into round ducts. The silencer reduces the noise level in the air duct significantly (refer the diagram «Noise level reduction»). For designing a ventilation system with low level of noise emission into the environment silencers should be used together with insulated fans.

■ **Design**

The galvanized steel casing of the SR silencer is filled with flameproof sound insulating material and equipped with protecting covering against fiber blowing-out. The SRF silencer casing consists of internal and external aluminium-alloy spiral seam tubes filled with flameproof sound insulating material. The casing inner surface is perforated and has the protecting over to prevent the fiber blowing-out. The minimum bending radius of the silencer is up to 2 diameters. Each standards size has several length modifications. The SR and SRF silencers are equipped with connecting flanges with rubber sealing for airtight connection to the air ducts.

■ **Mounting**

The silencers can be mounted in any position. Installing several silencers in series is preferable to improve sound absorption effect. To prevent the flexible silencer sagging it should be fixed not only at the ends but also in the middle.

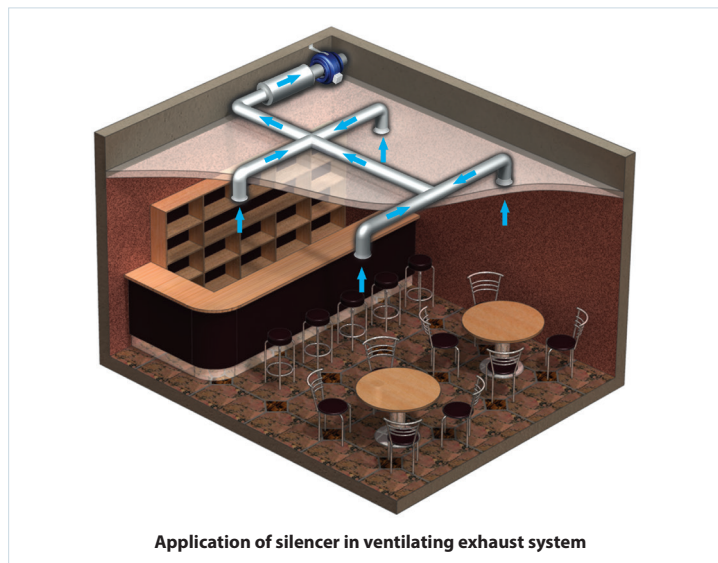

**Designation key**

Series	Air duct diameter [mm]	Length
SR SRF	100; 125; 150; 160; 200; 250; 315; 355; 400	600; 900; 1200; 2000

Noise level reduction, dB (Octave-frequency band [Hz])

	63 Hz	125 Hz	250 Hz	500 Hz	1000 Hz	2000 Hz	4000 Hz	8000 Hz
SR 100/600	4	8	10	20	34	30	13	14
SR 100/900	5	10	15	23	44	30	16	15
SR 100/1200	6	11	19	28	50	34	20	18
SR 125/600	3	5	6	15	28	17	10	9
SR 125/900	4	9	12	22	43	22	16	12
SR 125/1200	4	9	16	27	48	27	21	17
SR 150/600	2	4	8	16	32	11	7	7
SR 150/900	3	5	9	18	36	25	13	14
SR 150/1200	4	8	14	25	43	30	18	19
SR 160/600	2	4	8	17	33	11	7	7
SR 160/900	2	5	10	19	37	25	13	15
SR 160/1200	4	10	14	24	42	30	19	20
SR 200/600	2	4	6	10	27	13	7	7
SR 200/900	3	7	11	20	39	23	8	7
SR 200/1200	4	10	14	23	40	26	13	12
SR 250/600	4	5	6	11	22	12	7	6
SR 250/900	4	5	7	16	32	20	12	10
SR 250/1200	4	6	8	17	34	22	14	12
SR 315/600	2	4	5	10	17	9	6	5
SR 315/900	3	5	8	17	30	14	10	8
SR 315/1200	4	7	11	22	36	18	14	10

Noise level reduction, dB (Octave-frequency band [Hz])

	63 Hz	125 Hz	250 Hz	500 Hz	1000 Hz	2000 Hz	4000 Hz	8000 Hz
SRF 100/600	6	8	13	22	28	34	17	20
SRF 100/900	8	10	15	25	33	40	21	23
SRF 100/2000	10	15	24	48	53	51	39	36
SRF 125/600	4	7	14	20	31	31	13	12
SRF 125/900	5	9	16	23	36	37	17	16
SRF 125/2000	7	15	23	47	55	50	28	25
SRF 150/600	3	7	12	32	40	40	19	20
SRF 150/900	4	8	14	40	48	49	26	25
SRF 150/2000	5	10	21	42	50	48	26	25
SRF 160/600	3	7	12	20	25	24	10	12
SRF 160/900	3	8	13	21	28	28	13	16
SRF 160/2000	5	11	20	40	48	48	25	25
SRF 200/600	2	5	12	20	26	21	10	10
SRF 200/900	3	6	12	22	28	24	12	13
SRF 200/2000	4	11	22	42	51	34	19	23
SRF 250/600	2	3	8	16	22	13	10	10
SRF 250/900	2	4	9	18	25	16	11	12
SRF 250/2000	3	6	16	30	39	27	17	22
SRF 315/600	2	4	9	18	21	12	7	9
SRF 315/900	2	5	11	21	24	14	8	10
SRF 315/2000	4	7	17	34	39	24	14	18

Overall dimensions

Type	Dimensions [mm]			Weight [kg]
	∅D	∅D1	L	
SR 100/600	99	202	600	2.9
SR 100/900	99	202	900	4.0
SR 100/1200	99	202	1200	5.2
SR 125/600	125	225	600	3.3
SR 125/900	125	225	900	4.6
SR 125/1200	125	225	1200	5.9
SR 150/600	149	252	600	3.7
SR 150/900	149	252	900	5.1
SR 150/1200	149	252	1200	6.5
SR 160/600	159	252	600	3.7
SR 160/900	159	252	900	5.1
SR 160/1200	159	252	1200	6.5
SR 200/600	198	318	600	4.65
SR 200/900	198	318	900	6.45
SR 200/1200	198	318	1200	8.1
SR 250/600	248	358	600	5.6
SR 250/900	248	358	900	7.8
SR 250/1200	248	358	1200	10
SR 315/600	313	403	600	7.1
SR 315/900	313	403	900	10.1
SR 315/1200	313	403	1200	13
SR 355/600	353	453	600	8.3
SR 355/900	353	453	900	11.6
SR 355/1200	353	453	1200	14.9
SR 400/600	398	503	600	10.75
SR 400/900	398	503	900	14.5
SR 400/1200	398	503	1200	18.2

Type	Dimensions [mm]			Weight [kg]
	∅D	∅D1	L	
SRF 100/600	99	220	600	1.6
SRF 100/900	99	220	900	2.4
SRF 100/2000	99	220	2000	5.2
SRF 125/600	124	270	600	2.0
SRF 125/900	124	270	900	3.0
SRF 125/2000	124	270	2000	6.6
SRF 150/600	149	270	600	2.1
SRF 150/900	149	270	900	3.1
SRF 150/2000	149	270	2000	6.8
SRF 160/600	159	270	600	2.1
SRF 160/900	159	270	900	3.2
SRF 160/2000	159	270	2000	7.0
SRF 200/600	199	320	600	2.6
SRF 200/900	199	320	900	3.9
SRF 200/2000	199	320	2000	8.6
SRF 250/600	249	370	600	3.0
SRF 250/900	249	370	900	4.5
SRF 250/2000	249	370	2000	10.1
SRF 315/600	314	420	600	3.4
SRF 315/900	314	420	900	5.1
SRF 315/2000	314	420	2000	11.4

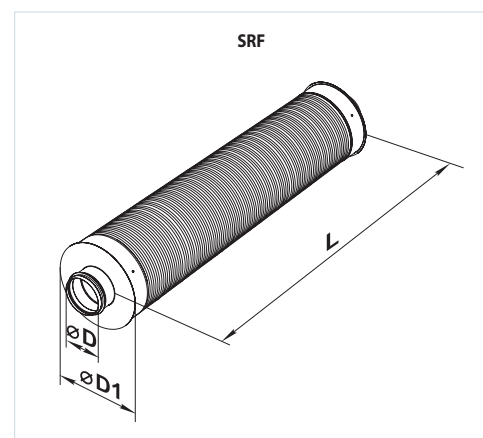
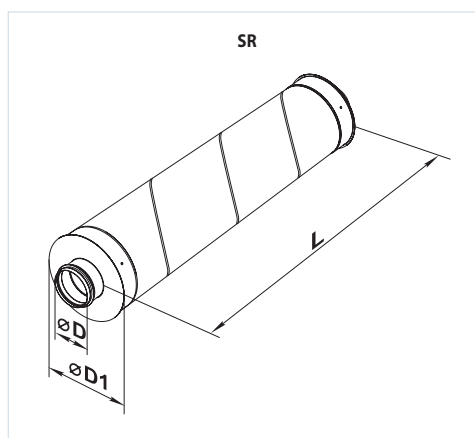

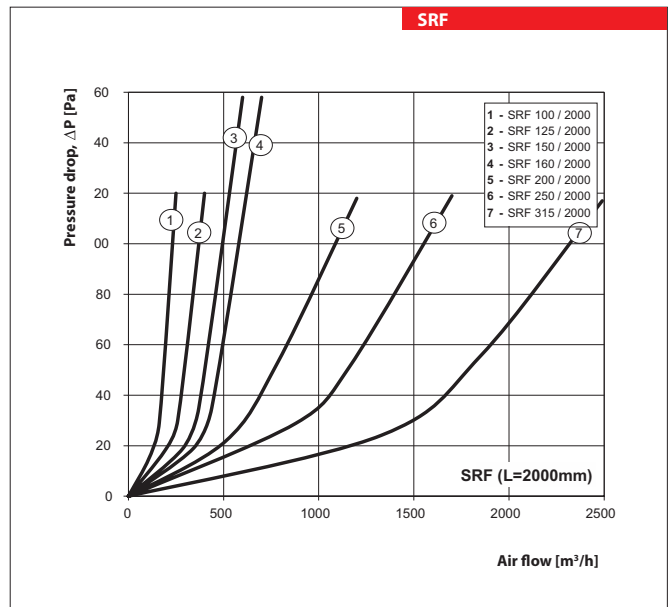
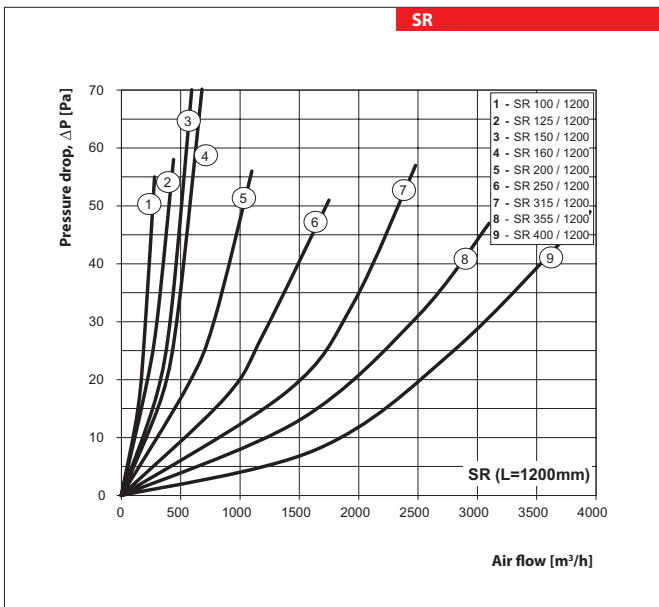
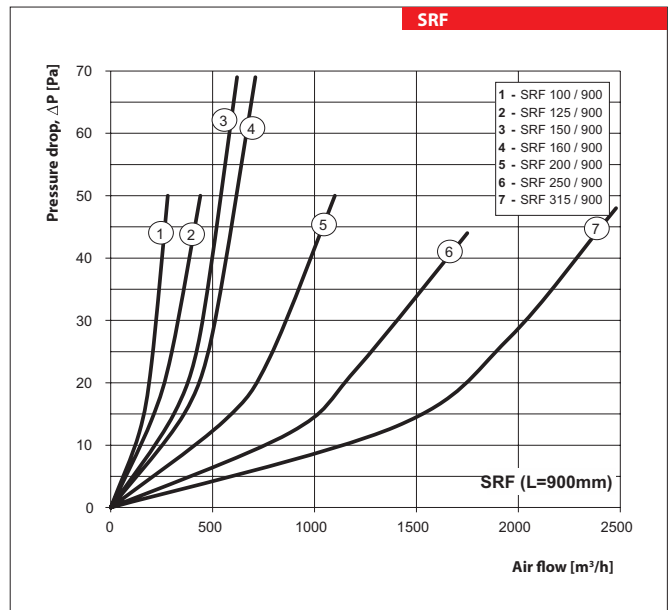
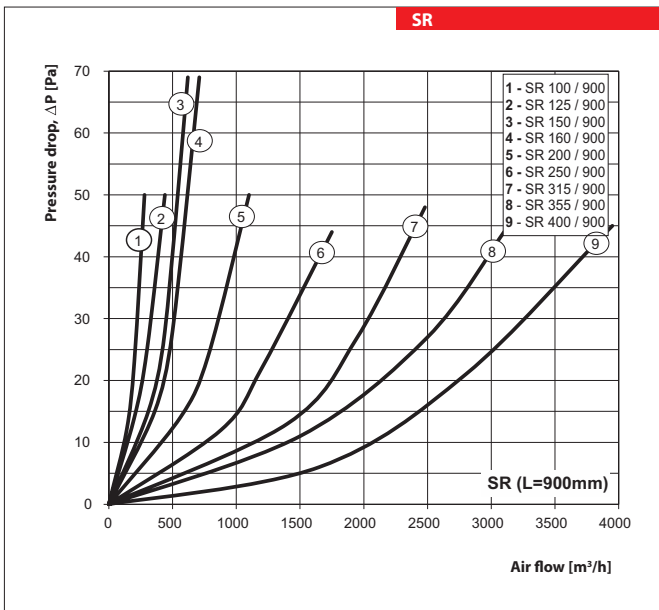
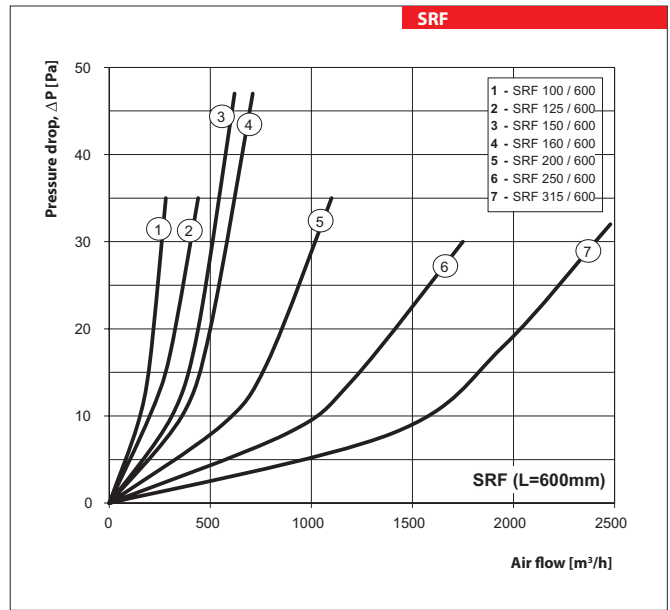
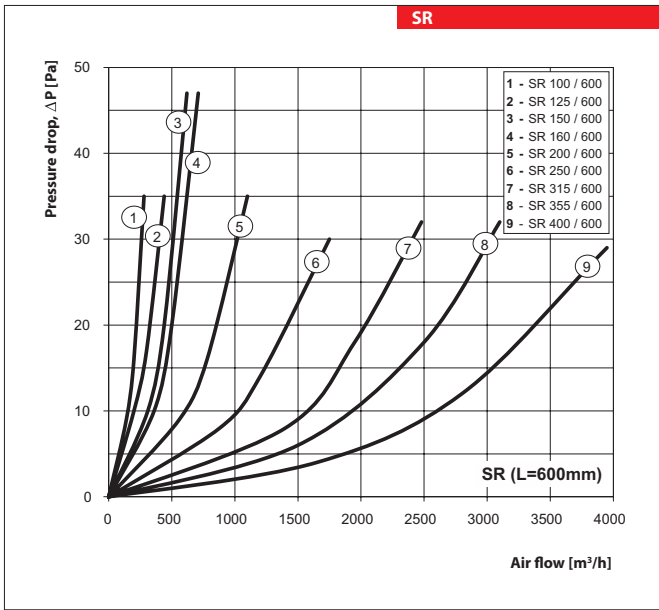

Series  
**SR**



■ **Applications**

The plate silencer is applied for noise absorption produced during the ventilating equipment operation and spread along the ducting systems. Suitable for installation into rectangular ducts. The silencer reduces the noise level in the air duct significantly (refer the diagram «Noise level reduction»). The silencer is applied jointly with the sound-insulated fan in case of high noise

level requirements not only to the air duct but to the equipment in general.

■ **Design**

Silencer casing and plate shells are made of galvanized steel. The plates are filled with flameproof sound insulating material with protecting covering to prevent the fiber blowing-out.

■ **Mounting**

The mounting is performed by means of flange connection with respect to air flow direction (indicated with an arrow on the casing). The straight portion of at least 1 m long before the silencer is recommended to provide the peak efficiency. Installation in series is preferable to attain the better effect.

	Noise level reduction, dB (Octave-frequency band [Hz])							
	63 Hz	125 Hz	250 Hz	500 Hz	1000 Hz	2000 Hz	4000 Hz	8000 Hz
SR 400x200	3	7	10	23	27	30	25	22
SR 500x250	3	6	11	22	26	25	27	22
SR 500x300	3	6	10	23	24	25	23	18
SR 600x300	3	6	10	21	24	30	24	17
SR 600x350	3	5	11	22	25	29	24	21
SR 700x400	4	7	10	15	22	19	21	18
SR 800x500	5	6	11	17	21	20	22	20
SR 900x500	3	6	10	16	20	20	21	15
SR 1000x500	4	6	11	16	21	21	23	17

**Designation key**

Series	Flange dimensions (WxH) [mm]
SR	400x200; 500x250; 500x300; 600x300; 600x350; 700x400; 800x500; 900x500; 1000x500

**Overall dimensions**

Type	Dimensions [mm]							Mass [kg]
	B	B1	B2	H	H1	H2	L	
SR 400x200	400	420	440	200	220	240	950	18.5
SR 500x250	500	520	540	250	270	290	950	20.5
SR 500x300	500	520	540	300	320	340	950	24.5
SR 600x300	600	620	640	300	320	340	950	26.5
SR 600x350	600	620	640	350	370	390	950	28.7
SR 700x400	700	720	740	400	420	440	1010	36.7
SR 800x500	800	820	840	500	520	540	1010	50.0
SR 900x500	900	920	940	500	520	540	1010	51.7
SR 1000x500	1000	1020	1040	500	520	540	1010	57.3

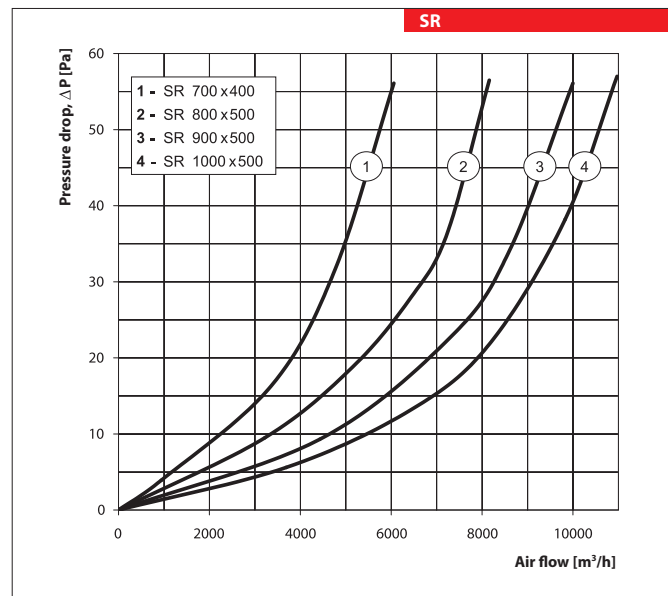
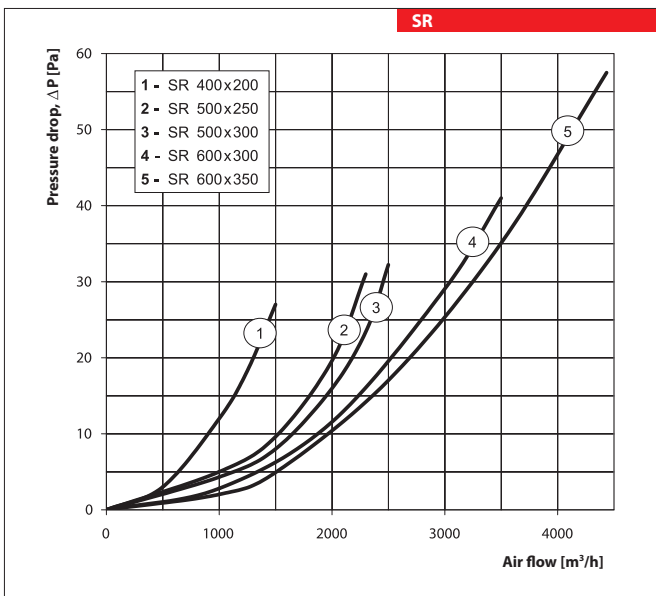
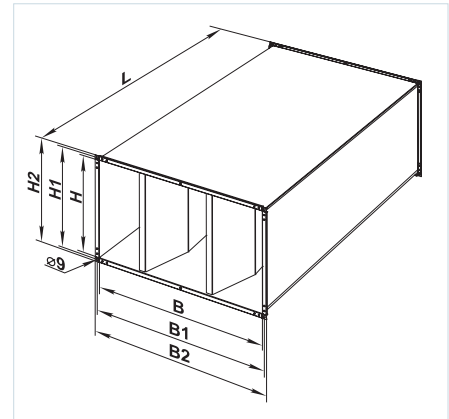

## NKP A21 V.2 Series



Heater for heat exchanger  
frost protection

### ■ Application

Duct electric heater for heat exchanger frost protection by means of supply air preheating and supply air duct temperature maintaining at a point that ensures heat exchanger freezing protection.

Compatible with round Ø125, 150, 160, 200, 250 and 315 mm air ducts.

### ■ Design

The casing and the control box are made of galvanized steel and the heating elements are made of stainless steel.

The heater casing is extra heat insulated with 20 mm non-flammable mineral wool layer.

The heater spigots are rubber sealed for airtight connection to the air ducts.

The NKP duct heaters are equipped with a power cable and a control cable for connection to a controller of an air handling unit.

Air temperature is controlled with a triac power controller that switches the maximum load on/off.

Load is commutated with a semiconductor (triac).

The heaters are equipped with overheat protection thermostats:

- ▶ self-resetting overheat protection thermostat actuated at +60 °C.

- ▶ emergency overheat protection thermostat actuated at +90 °C.

### ■ Mounting

The heater design ensures its connection to round air ducts by means of the clamps from the delivery set.

The arrow on the heater casing must match the air flow direction in the system.

The heater is controlled by the ventilation unit through the cable supplied and already connected to the heater at the factory.

The control box cover must be directed upwards with the maximum deviation angle 90°.

The control box cover must not be directed downwards.

### Overall dimensions

Model	Dimensions [mm]				
	Ø D	B	H	L	L1
NKP 125-0.6-1	125	164	249	306	192
NKP 125-0.8-1					
NKP 125-1.2-1					
NKP 150-0.8-1	150	189	280	306	192
NKP 150-1.2-1					
NKP 150-1.7-1					
NKP 150-2.0-1					
NKP 160-0.8-1	160	197	291	306	192
NKP 160-1.2-1					
NKP 160-1.7-1					
NKP 160-2.0-1					
NKP 200-1.2-1	200	239	336	306	192
NKP 200-1.7-1					
NKP 200-2.0-1					
NKP 250-1.2-1	250	287	388	307	192
NKP 250-2.0-1					
NKP 250-3.0-1					
NKP 315-2.0-1	315	353	454	306	192
NKP 315-3.0-1					

### Technical data

Model	Min. air flow [m³/h]	Power [kW]	Current [A]
NKP 125-0.6-1	60	0.6	2.6
NKP 125-0.8-1	80	0.8	3.5
NKP 125-1.2-1	90	1.2	5.2
NKP 150-0.8-1	80	0.8	3.5
NKP 150-1.2-1	90	1.2	5.2
NKP 150-1.7-1	160	1.7	7.4
NKP 150-2.0-1	170	2.0	8.7
NKP 160-0.8-1	80	0.8	3.5
NKP 160-1.2-1	150	1.2	5.2
NKP 160-1.7-1	160	1.7	7.4
NKP 160-2.0-1	170	2.0	8.7
NKP 200-1.2-1	150	1.2	5.2
NKP 200-1.7-1	160	1.7	7.4
NKP 200-2.0-1	170	2.0	8.7
NKP 250-1.2-1	180	1.2	5.2
NKP 250-2.0-1	200	2.0	8.7
NKP 250-3.0-1	375	3.0	13.0
NKP 315-2.0-1	220	2.0	8.7
NKP 315-3.0-1	320	3.0	13.0

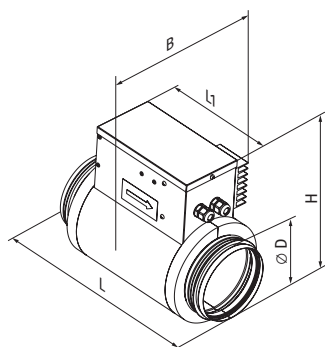

### Designation key

Series	Connected air duct diameter [mm]	Heater power, kW	Phase	Options
NKP	125; 150; 160; 200; 250; 315	0.6; 0.8; 1.2; 1.7; 2.0; 3.0	1: single-phase	A21 V.2: compatible with A21 automation, without a DB-9M connector

**Electric heater power selection diagram**

**Minimum temperature enabling efficient operation of the NKP freeze protection heater**

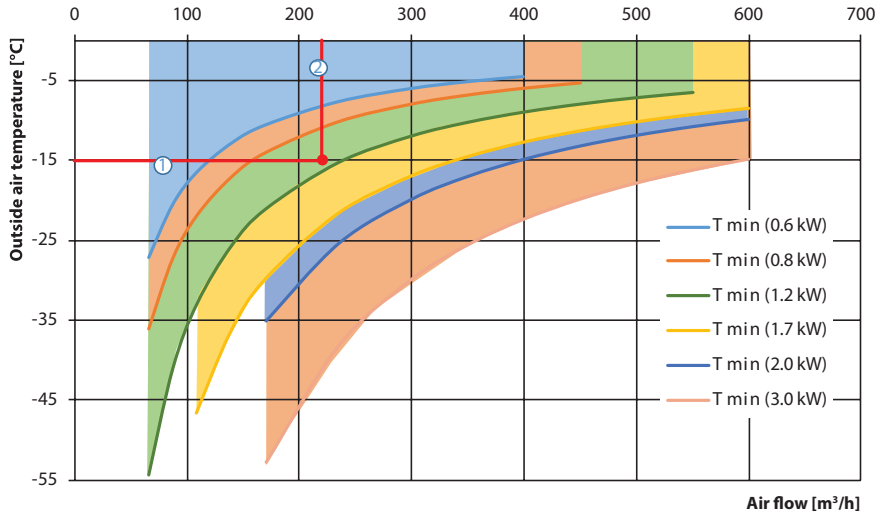

**How to use NKP electric heater diagrams**

- ▶ Selection of the NKP heater model compatible with VUT 350 VB EC A21 air handling unit. The rated winter outside air temperature is -15 °C. The rated air flow is 220 m³/h. Starting from the rated winter outside air temperature (1) draw a horizontal line till the air flow axis (2). The NKP heater with heating capacity 1200 W is able to provide efficient heat exchanger frost protection.
- ▶ The NKP 160-1.2-1 with the diameter matching the spigot diameter of the VUT 350 VB EC A21 air handling unit is a suitable model.

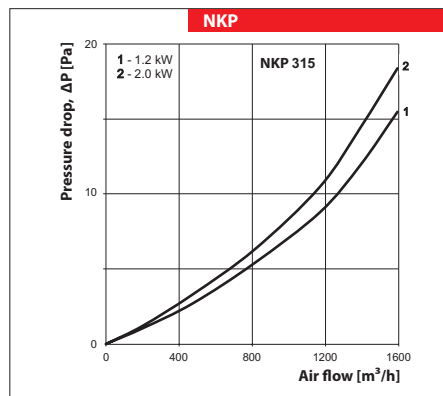
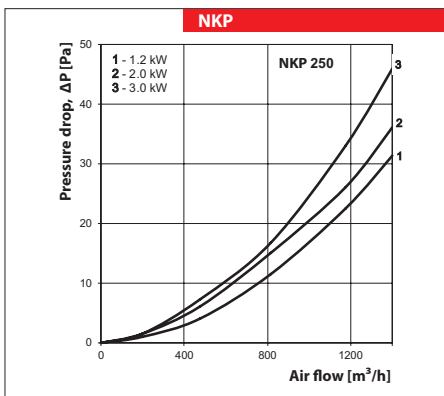
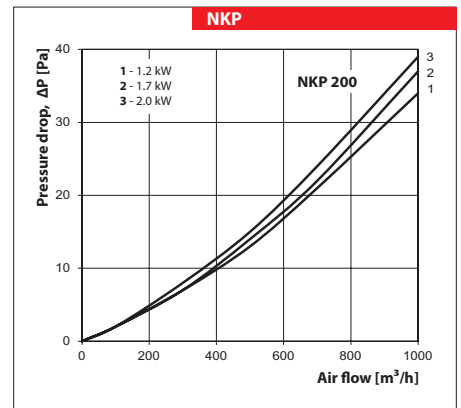
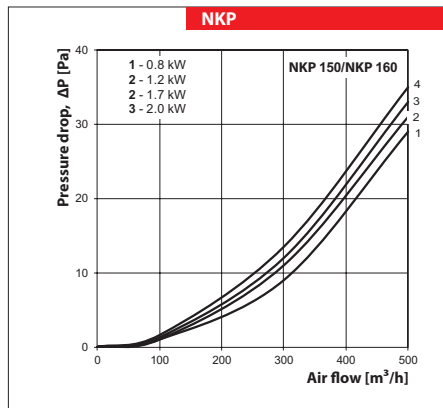
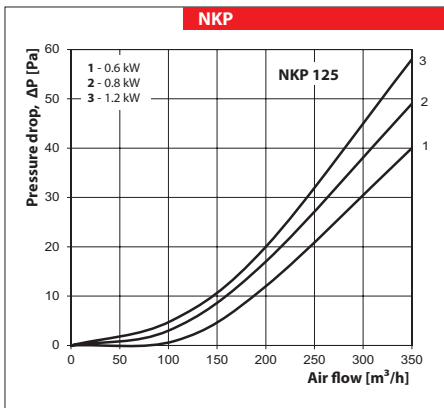

## NKD A21 V.2 Series



Duct heater for supply air post-heating with external control

### Application

The heater is designed for integration into a ventilation system and joint operation with an air handling unit equipped with a control system used to switch on the heater and control its operation.

The heater maintains the supply duct air temperature at a point set by the unit controller.

### Design

The casing, the junction box and the heater cover are made of galvanized steel with the heating elements in stainless steel. The heater casing is additionally heat-insulated with 20 mm non-flammable mineral wool layer. The heaters are equipped with rubber seals for airtight connection to the air ducts.

NKD A21 V.2 duct heaters are equipped with a factory-wired power cable and a control cable, and also have a duct temperature sensor that is connected to the ventilation unit. Temperature control is carried out smoothly by the ventilation

unit controller due to the PWM signal in cycles of 10 seconds. Load commutation is carried out by the semiconductor device (triac).

The heaters are equipped with overheat thermostats:

- ▶ main overheat protection with automatic reset at +50 °C
- ▶ emergency overheat protection with manual reset at +90 °C

### Mounting

The heater design ensures its mounting on the round ducts in any position by means of clamps (included in delivery).

The air flow direction shall match the direction of the arrow on the heater casing.

In case of horizontal mounting the control box must be installed with the cover upwards.

Swivel range from the normal position up to max. 90°.

Do not install the control box with the cover downwards.

### Overall dimensions of the units

Model	Dimensions [mm]				
	Ø D	B	H	L	L1
NKD 125-0.6-1	125	164	249	306	192
NKD 125-0.8-1					
NKD 125-1.2-1					
NKD 150-0.8-1	150	189	280	306	192
NKD 150-1.2-1					
NKD 150-1.7-1					
NKD 150-2.0-1					
NKD 160-0.8-1	160	197	291	306	192
NKD 160-1.2-1					
NKD 160-1.7-1					
NKD 160-2.0-1					
NKD 200-1.2-1	200	239	336	306	192
NKD 200-1.7-1					
NKD 200-2.0-1					
NKD 250-1.2-1	250	287	388	307	192
NKD 250-2.0-1					
NKD 250-3.0-1					
NKD 315-2.0-1	315	353	454	306	192
NKD 315-3.0-1					

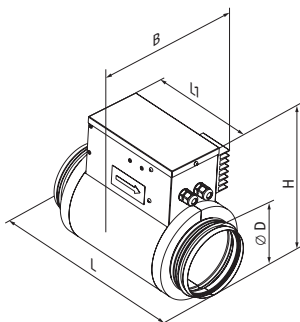

### Technical data

Model	Min. air flow [m³/h]	Power [kW]	Current [A]
NKD 125-0.6-1	60	0.6	2.6
NKD 125-0.8-1	80	0.8	3.5
NKD 125-1.2-1	90	1.2	5.2
NKD 150-0.8-1	80	0.8	3.5
NKD 150-1.2-1	90	1.2	5.2
NKD 150-1.7-1	160	1.7	7.4
NKD 150-2.0-1	170	2.0	8.7
NKD 160-0.8-1	80	0.8	3.5
NKD 160-1.2-1	150	1.2	5.2
NKD 160-1.7-1	160	1.7	7.4
NKD 160-2.0-1	170	2.0	8.7
NKD 200-1.2-1	150	1.2	5.2
NKD 200-1.7-1	160	1.7	7.4
NKD 200-2.0-1	170	2.0	8.7
NKD 250-1.2-1	180	1.2	5.2
NKD 250-2.0-1	200	2.0	8.7
NKD 250-3.0-1	375	3.0	13.0
NKD 315-2.0-1	220	2.0	8.7
NKD 315-3.0-1	320	3.0	13.0

### Designation key

Series	Connected air duct diameter [mm]	Heater power [kW]	Phases	Options
NKD	125; 150; 160; 200; 250; 315	0.6; 0.8; 1.2; 1.7; 2.0; 3.0	1: single-phase	A21 V.2: compatible with A21 automation, without a DB-9M connector

**Technical data**

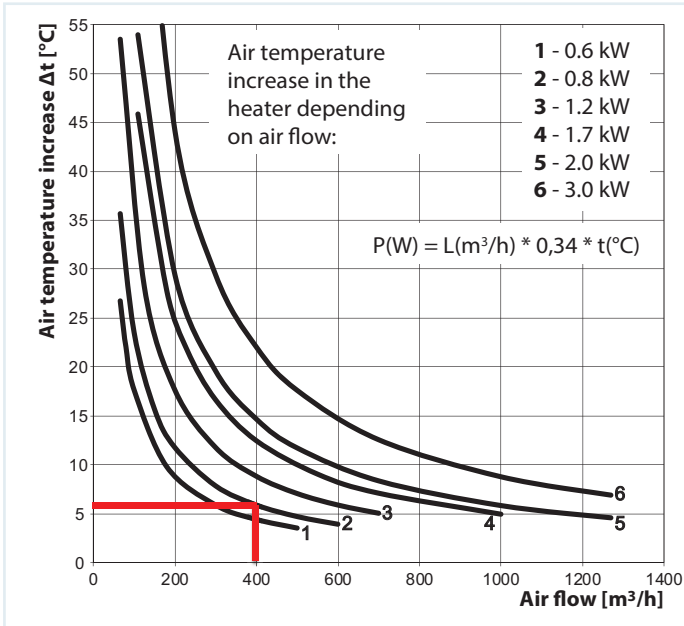

**The NKD heater parameters calculation example:**

It is necessary to select a heater for supply air post-heating to a temperature of +24 °C, provided the temperature downstream of the heat exchanger is +17 °C. Therefore, it is essential to increase temperature by 7 °C. The ventilation system incorporates the VENTS VUT 350 VB EC A21 air handling unit. The rated air flow is 400 m<sup>3</sup>/h. Determine the intersection of the post-heating temperature line (+7 °C) and the rated air flow line (400 m<sup>3</sup>/h).

In this case the 1200 W heater capacity provides necessary post-heating (+7 °C). The NKD heater 160-1.2-1 kW with the diameter matching the spigot diameter of the VUT 350 VB EC A21 air handling unit is a suitable model.

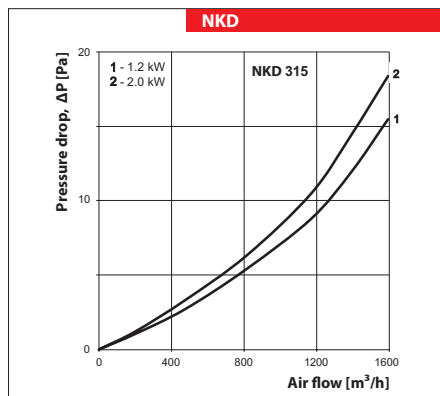
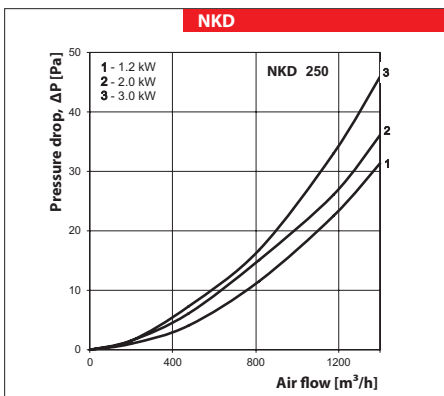
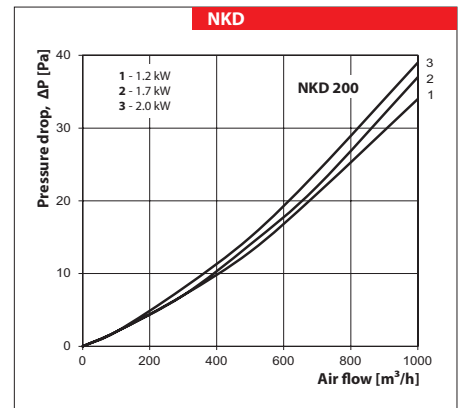
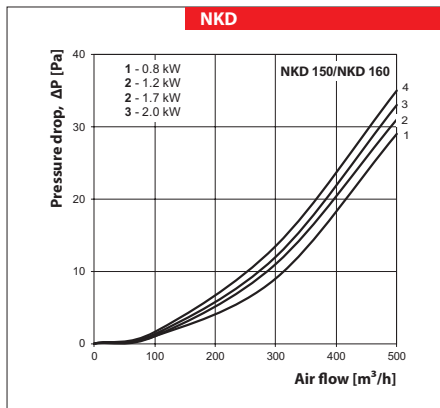
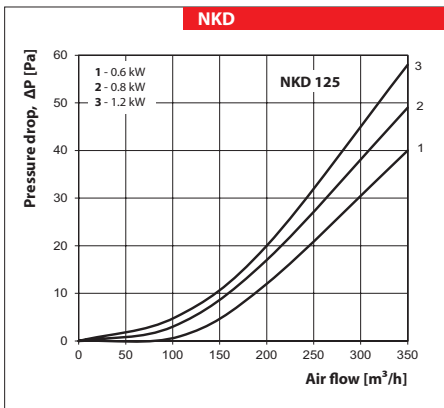

## SH-32 series



### Application

The hydraulic U-trap SH-32 is designed for condensate drainage from heat exchangers and coolers in ventilation and air conditioning systems.

The U-trap must be connected to a drain pan pipe F 18 mm.

### A mounting example for the SH-32 U-trap

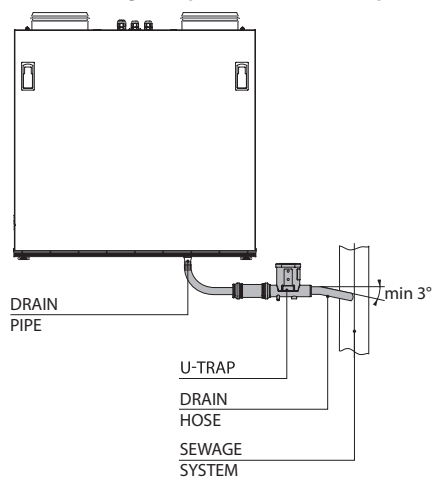

### Design

When the condensate is drained from the ventilation unit, it passes the drain pipe through the flexible PVC hose, the connection coupling and reaches the U-trap with the mechanical locking device that does not let sewage system odours out after the hydraulic seal dries out. Then the condensate is moved to the sewage system.

The SH-32 set consists of:

1. Coupling 32/32;
2. Rubber sleeve 32/20;
3. U-trap;
4. PVC hose 15x2 of 1000 mm length.

### Overall dimensions:

Type	Dimensions, mm		
	∅D	B	L
SH-32	32	103	1000

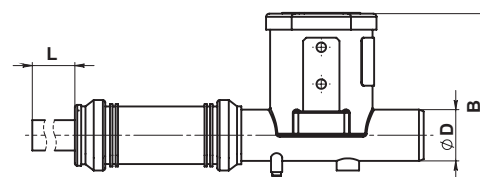

**BACKDRAFT DAMPERS**

Series  
**KOM**



■ **Applications**

Spring-loaded backdraft damper for round ducts. The damper prevents back draft when the system is off. The blades are opened with air flow and are closed with a spring.

■ **Design**

The damper is made of galvanized steel housing with spring-loaded aluminium blades.

■ **Modifications**

**KOMu** model is sealed with foamed rubber for noise absorption and extra air tightness.

■ **Mounting**

The damper is connected to round air ducts and fixed with clamps. The blade axis should be in vertical position. Correct air flow direction should be considered.

**Overall dimensions**

Type	Dimensions [mm]		Mass [kg]
	ØD	L	
KOM 100 KOMu 100	99	80 90	0.18
KOM 125 KOMu 125	124	100 110	0.27
KOM 150 KOMu 150	149	115 125	0.38
KOM 160 KOMu 160	159	120 130	0.42
KOM 200 KOMu 200	199	145 155	0.63
KOM 250 KOMu 250	249	165 175	0.90
KOM 315 KOMu 315	314	190 200	1.31

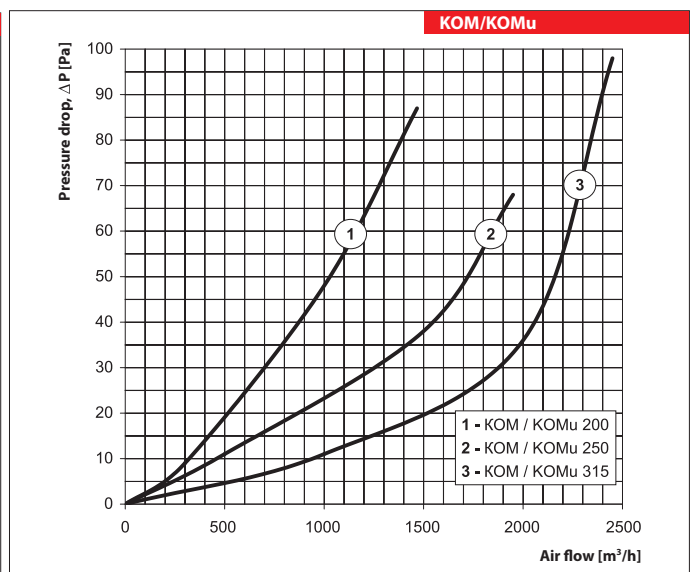
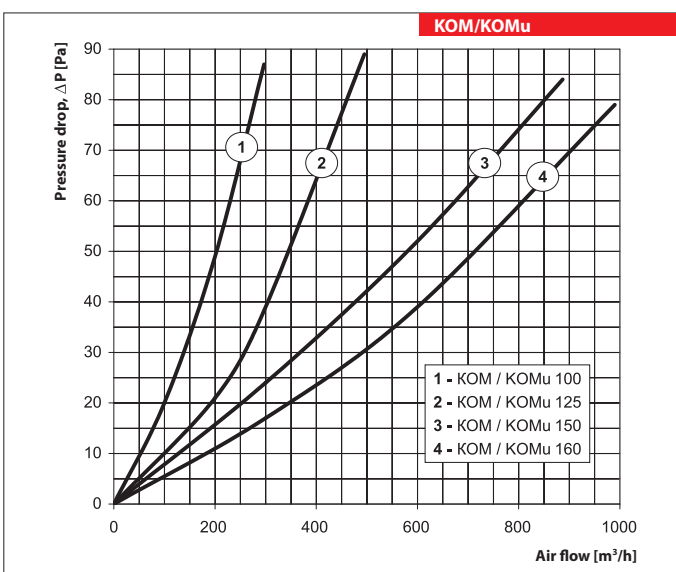
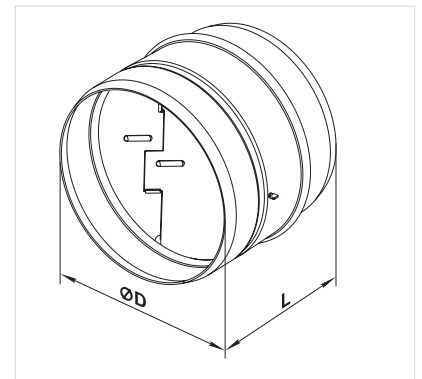

**Designation key**

Series	Spigot diameter [mm]
KOM/KOMu	100; 125; 150; 160; 200; 250; 315

Series  
**KOM1**

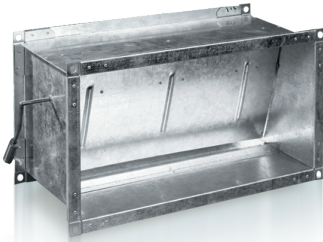

■ **Applications**

Gravity backdraft damper for air flow cut-off in rectangular air duct. The damper prevents back draft when the system is off.

■ **Design**

The housing and the rotary blade are made of galvanized steel. The damper blade is opened by the air pressure and is closed when the system is off. The damper handle counterweight enables regulation of the damper opening-closing sensitivity.

■ **Mounting**

Standard spigot connection for rectangular air ducts. The blade axis should be in horizontal position allowing the blade to close by its own weight. Correct airflow direction should be considered.

**Overall dimensions**

Type	Dimensions [mm]								Mass [kg]
	B	B1	B2	B3	H	H1	H2	L	
KOM1 400x200	400	420	440	461	200	220	240	202	2.9
KOM1 500x250	500	520	540	561	200	270	290	202	3.73
KOM1 500x300	500	520	540	561	300	320	340	202	4.1
KOM1 600x300	600	620	640	661	300	320	340	202	4.64
KOM1 600x350	600	620	640	661	350	370	390	202	5.03

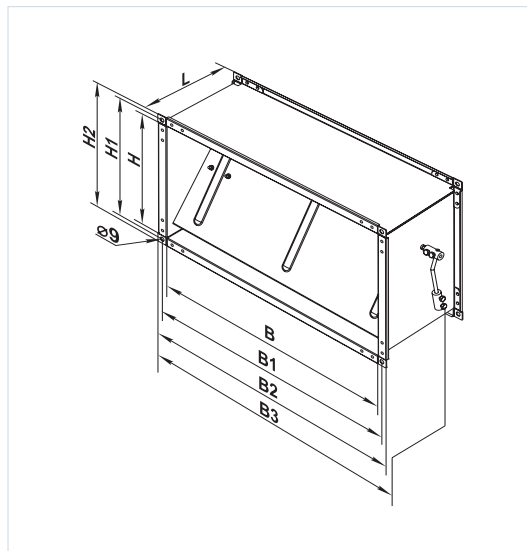

**Designation key**

Series	Flange dimensions [mm]
KOM 1	400x200; 500x250; 500x300; 600x300; 600x350

**AIR DAMPERS**

Series  
**KR**



■ **Applications**

Air damper for air flow control in rectangular air ducts. Compatible with duct sizes 400x200, 500x250, 500x300, 600x300, 600x350 mm.

■ **Design**

The housing and the blade made of galvanized steel. Lever with metal handle and fixing clamp let fix the damper position with a butterfly bolt.

■ **Mounting**

Standard connection flange for rectangular air ducts or other ventilation system components. Flanges should be connected with galvanized bolts and clamps.

**Overall dimensions**

Type	Dimensions [mm]								Mass [kg]
	B	B1	B2	B3	H	H1	H2	L	
KR 400x200	400	420	440	460	200	220	240	202	3.0
KR 500x250	500	520	540	560	250	270	290	202	3.8
KR 500x300	500	520	540	560	300	320	340	202	3.1
KR 600x300	600	620	640	660	300	320	340	202	4.2
KR 600x350	600	620	640	660	350	370	390	202	5.1

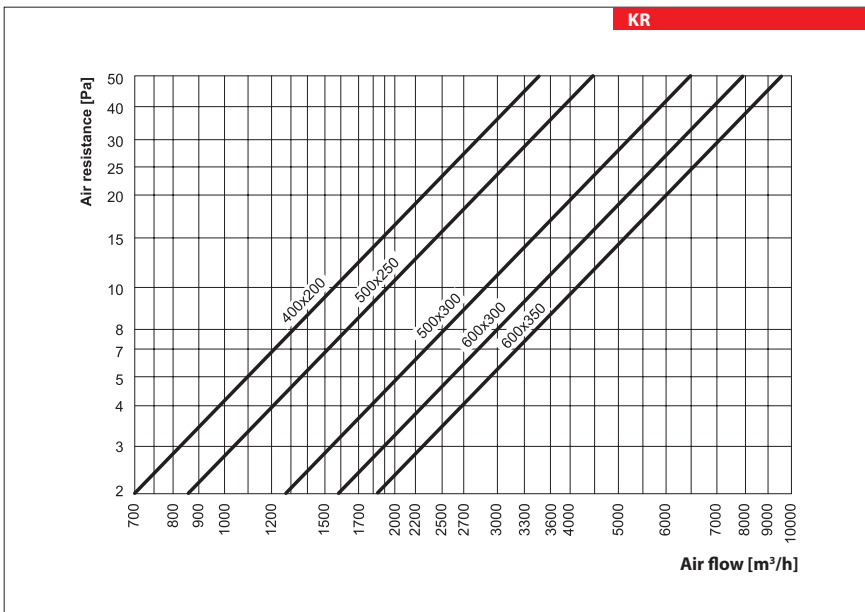
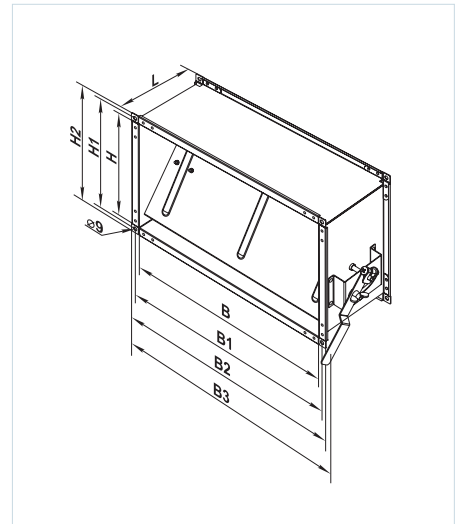

**Designation key**

Series	Flange dimensions (WxH) [mm]
KR	400x200; 500x250; 500x300; 600x300; 600x350

Series  
**KR**



■ **Application**

Air damper for air flow control in round air ducts. Compatible with duct sizes: Ø 80, 100, 125, 150, 160, 200, 250, 315, 355, 400, 450, 500, 550 and 630 mm.

■ **Design**

The housing and the blade made of galvanized steel.

Lever with metal handle and fixing clamp. In closed position about 10 % of cross section is left open. Connection spigots with rubber sealing gaskets.

■ **Mounting**

The damper is connected to round air ducts and fixed with clamps.

**Overall dimensions**

Type	Dimensions [mm]			Mass [kg]
	ØD	B	L	
KR 80	79	140	200	0.57
KR 100	99	170	200	0.68
KR 125	124	195	200	0.82
KR 150	149	220	200	0.95
KR 160	159	230	200	1.01
KR 200	199	270	200	1.29
KR 250	249	320	200	1.64
KR 315	314	385	240	2.51
KR 355	348	425	240	2.84
KR 400	399	470	240	3.38
KR 450	449	520	240	3.94
KR 500	499	570	240	5.72
KR 550	549	620	240	6.47
KR 630	629	700	240	7.76

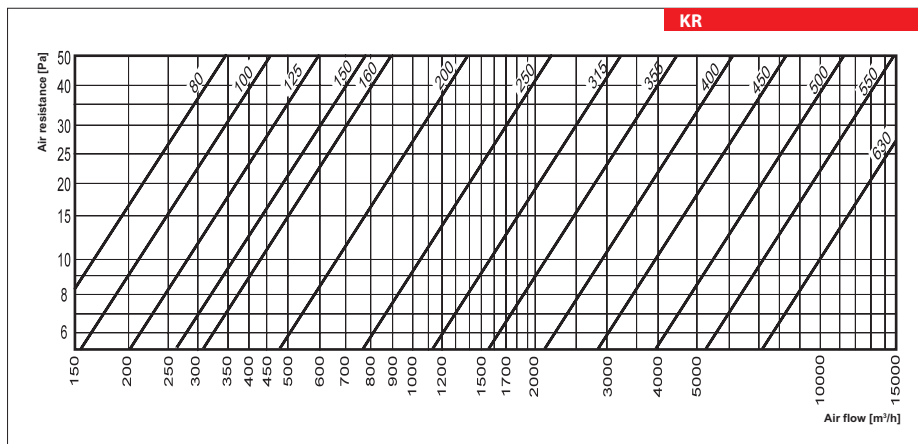
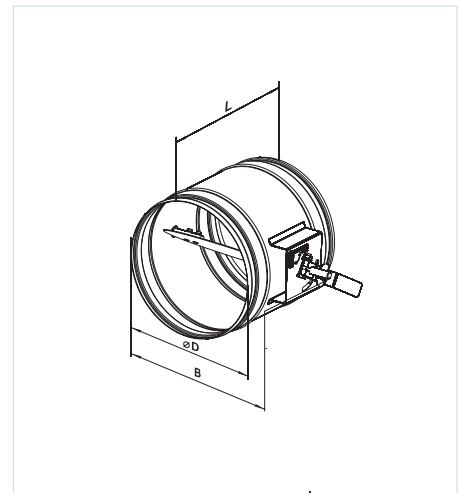

**Designation key**

Series	Spigot diameter [mm]
KR	80; 100; 125; 150; 160; 200; 250; 315; 355; 400; 450; 500; 550; 630

**AIR DAMPERS**

**Series  
KRV**



**Application**

Air damper for air flow cut-off in round air ducts. Compatible with duct sizes: Ø 80, 100, 125, 150, 160, 200, 250, 315, 355, 400, 450, 500, 550 and 630 mm.

**Design**

The housing and the blade made of galvanized steel. Connecting spigots with rubber sealing gaskets. Universal shaft for automatic actuator (available upon

separate order). Compatible actuators are shown in the table below.

**Mounting**

The damper is connected to round air duct and fixed with clamps.

**Compatible Belimo actuators**

Model	Actuator drive			
	Electric actuator, 230 V	Electric actuator with spring return, 230 V	Electric actuator, 24 V	Electric actuator with spring return, 24 V
KRV 80	CM230/LM230A	TF230	CM24 / LM24A	TF24
KRV 100			CM24 / LM24A	TF24
KRV 125	CM230/LM230A	TF230	CM24 / LM24A	TF24
KRV 150			CM24 / LM24A	TF24
KRV 160	CM230/LM230A	TF230	CM24 / LM24A	TF24
KRV 200			CM24 / LM24A	TF24
KRV 250	CM230/LM230A	TF230	CM24 / LM24A	TF24
KRV 315			CM24 / LM24A	TF24
KRV 355	CM230/LM230A	TF230	CM24 / LM24A	TF24
KRV 400			CM24 / LM24A	TF24
KRV 450	CM230/LM230A	TF230	CM24 / LM24A	TF24
KRV 500			CM24 / LM24A	TF24
KRV 550	CM230/LM230A	TF230	CM24 / LM24A	TF24
KRV 630			CM24 / LM24A	TF24

**Overall dimensions**

Type	Dimensions [mm]				Mass [kg]
	ØD	B	L	H	
KRV 80	79	190	200	170	0.6
KRV 100	99	220	200	180	0.72
KRV 125	124	245	200	195	0.86
KRV 150	149	270	200	205	1.01
KRV 160	159	280	200	210	1.07
KRV 200	199	320	200	230	1.33
KRV 250	249	370	200	255	1.68
KRV 315	314	435	240	-	2.44
KRV 355	348	475	240	-	2.75
KRV 400	399	520	240	-	3.26
KRV 450	449	570	240	-	3.78
KRV 500	499	620	240	-	5.55
KRV 550	549	670	240	-	6.27
KRV 630	629	750	240	-	7.49

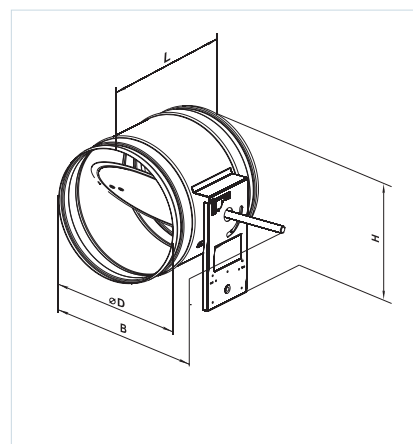
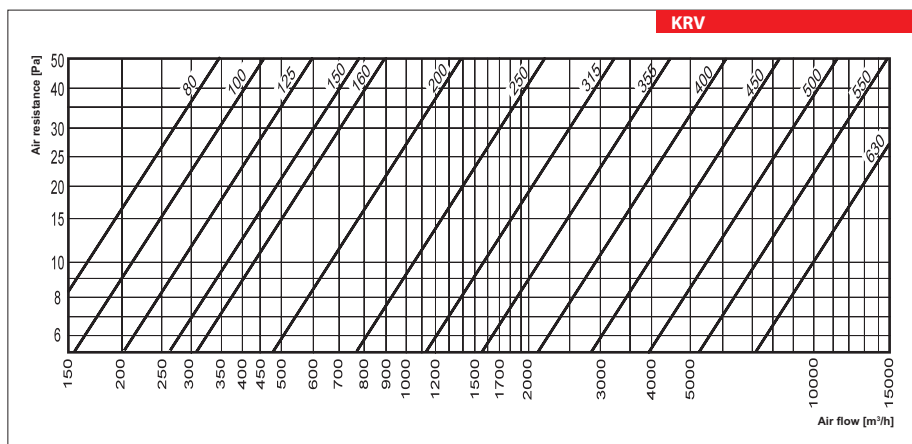

**Designation key**

Series	Spigot diameter [mm]
KRV	80; 100; 125; 150; 160; 200; 250; 315; 355; 400; 450; 500; 550; 630

**Accessories**



Series  
**RRV**



■ **Application**

Multi-blade damper for air flow control or cut-off in rectangular air ducts.

Compatible with duct sizes 400x200, 500x250, 500x300, 600x300, 600x350, 700x400, 800x500, 900x500 and 1000x500 mm.

■ **Design**

The housing made of galvanized steel. The aluminium blades driven by plastic gearwheels. Lever with removable metal handle and fixing clamp.

Universal shaft for automatic actuator. Compatible

actuators are shown in the table below (available upon separate order). For actuator connection the metal handle should be removed from the shaft.

■ **Mounting**

Standard connection flange for rectangular air ducts or other ventilation system components.

Flanges should be connected with galvanized bolts and clamps.

**Overall dimensions**

Type	Dimensions [mm]								Mass [kg]
	B	B1	B2	B3	H	H1	H2	L	
RRV 400x200	400	420	440	540	200	220	240	170	3.5
RRV 500x250	500	520	540	640	250	270	290	170	4.2
RRV 500x300	500	520	540	640	300	320	340	170	4.9
RRV 600x300	600	620	640	740	300	320	340	170	5.4
RRV 600x350	600	620	640	740	350	370	390	170	5.7
RRV 700x400	700	720	740	840	400	420	440	170	7.7
RRV 800x500	800	820	840	940	500	520	540	170	8.8
RRV 900x500	900	920	940	1040	500	520	540	170	9.6
RRV 1000x500	1000	1020	1040	1140	500	520	540	170	10.3

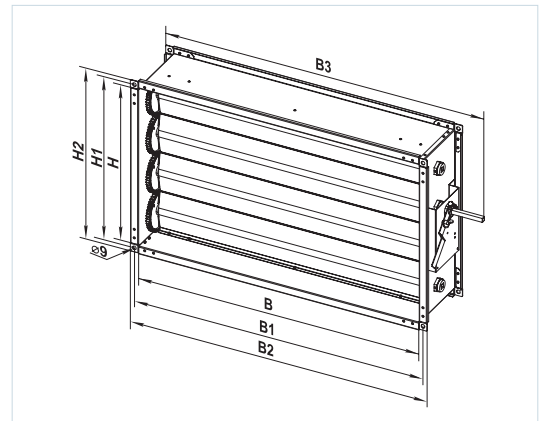

**Compatible Belimo actuators**

Model	Actuator type			
	Electric actuator, 230 V	Spring return electric actuator, 230 V	Electric actuator, 24 V	Spring return electric actuator, 24 V
RRV 400x200	CM230/ LM230A	TF230/LF230	CM24/ LM24A	TF24/LF24
RRV 500x250				
RRV 500x300				
RRV 600x300				
RRV 600x350	LM230A	LF230	LM24A	LF24
RRV 700x400				
RRV 800x500				
RRV 900x500				
RRV 1000x500				

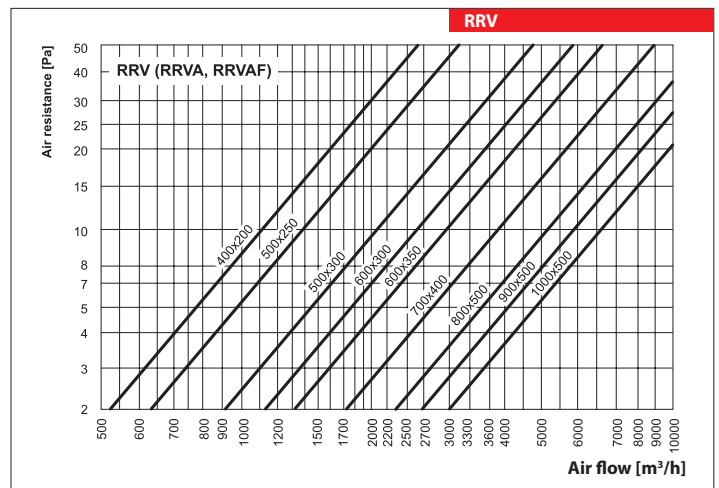

**Designation key**

Series	Flange dimensions [mm]
RRV	400x200; 500x250; 500x300; 600x300; 600x350; 700x400; 800x500; 900x500; 1000x500

**Accessories**



page 496



page 497



page 498



page 499

CONTROL PANELS

**A22**

**A22 WiFi**



**Application**

The A22/A22 WiFi control panels are used for control of industrial and domestic air handling units with an A21 automation system.

**Installation and connection**

The A22/A22 WiFi control panels are suitable for wall flush and wall surface mounting. Mounting boxes for wall surface mounting and wall flush mounting are included in the delivery set. Connection of the control panel is carried out according to the User's manual of the unit.

**Technical data**

Wired A22 control panel (connected to the unit with a cable)

	<b>A22</b>
Voltage [V]	24
Maximum current [A]	0.025
Cable type	4x0.25 mm <sup>2</sup>
Temperature range [°C]	from +10 up to +45
Humidity range [%]	from 10 % up to 80 % (no condensation)
SEC class	IP40

Wireless A22 WiFi control panel (connected to the unit via Wi-Fi)

	<b>A22 WiFi</b>
Supply voltage, 50 (60) Hz [V]	110-230
Maximum current [A]	0.012
Cable type	2x0.35 mm <sup>2</sup>
Temperature range [°C]	from +10 up to +45
Humidity range [%]	from 10 % up to 80 % (no condensation)
Casing material	Plastic
Sensor surface material	Glass
SEC class	IP40
Weight [g]	190
<b>Wi-Fi data</b>	
Standard	IEEE 802.11 b/g/n
Frequency band [GHz 2.4]	2.4
Transmission power [mW] (dBm)	100 (+20)
Network	DHCP
WLAN safety	WPA, WPA2

**Overall dimensions**

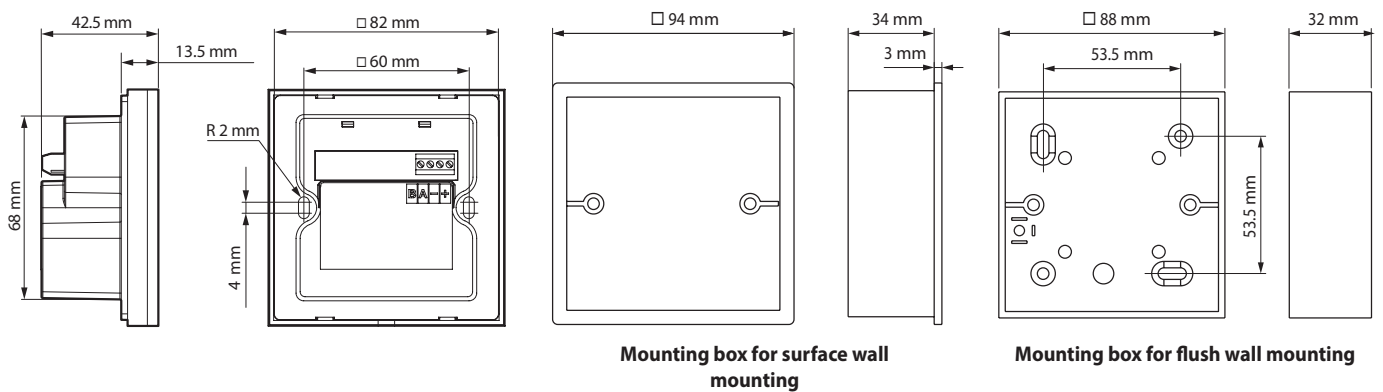

## A25



### ■ Application

The A25 control panel with a sensor display is used for control of industrial and domestic air handling units with an A21 automation system.

### ■ Installation

Connection and mounting of the control panel are carried out according to the User's manual of the unit.

### ■ Technical data

	A25
Voltage DC [V]	12-32
Current at 24 VDC [A]	0.1
Power cable type (10 m)	4x0.25 mm <sup>2</sup>
Temperature range [°C]	from +10 up to +45
Humidity range [%]	from 10 % up to 80 % (no condensation)
SEC class	IP20

### ■ Overall dimensions

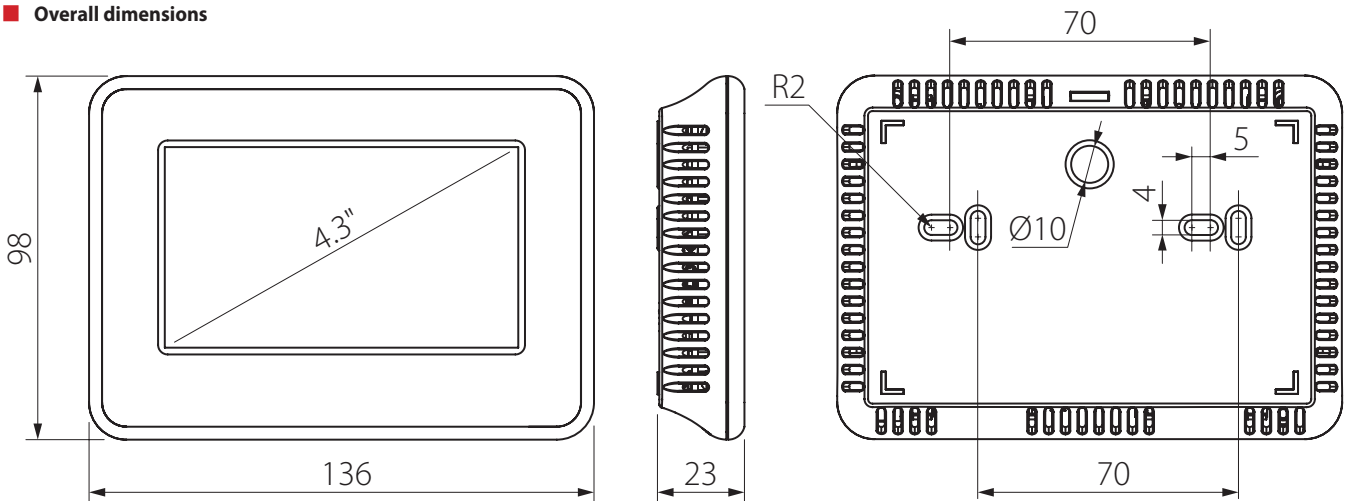

**HUMIDITY SENSOR**

Humidity sensor  
**HV-2**



■ **Features**

The HV-2 humidity sensor is designed to control humidity in ventilation, air conditioning and heating systems.

■ **Design**

The HV-2 humidity sensor is compatible with air handling units with an S14 or S21 automation system.

■ **Mounting**

The HV-2 humidity sensor is designed to control humidity in ventilation, air conditioning and heating systems.

**On the bracket in the exhaust air duct of the unit**

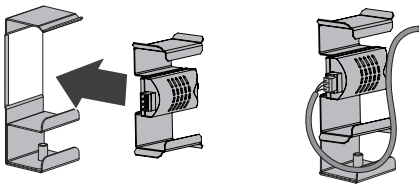

**In the exhaust air duct of the unit on a threaded rivet or plastic support**

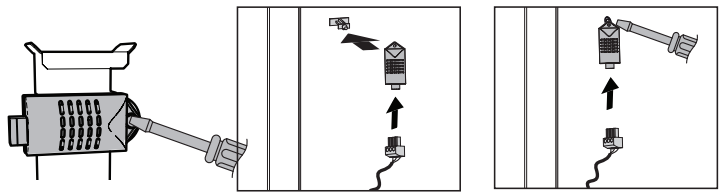

**On In the exhaust air duct upstream of the heat exchanger (only for VUT 160 V(B) EC units)**

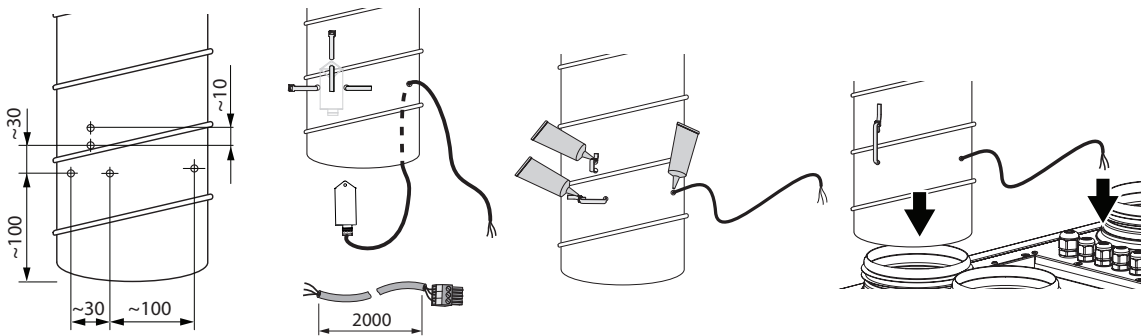

**Overall dimensions**

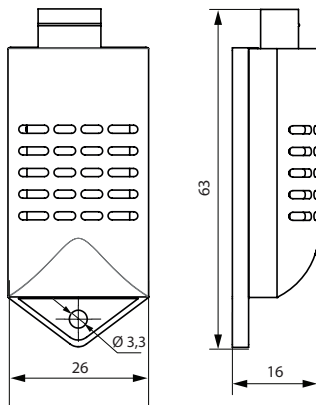

## Electro-mechanical humidistats

### HR-S



#### ■ Purpose

The humidistat is designed for controlling humidification and/or dehumidification in ventilation, air conditioning and heating systems. Can also be used to alarm when the humidity exceeds or falls below a pre-set level.

#### ■ Design

The single-stage humidistat HR-S uses a synthetic element as sensor medium. The synthetic element stretches as the humidity increases and shrinks as the humidity decreases.

#### ■ Mounting

The humidistat is designed for indoor mounting on the wall surface.

#### Technical data

Switch contact	250 V AC, 5 A
Moisture [%]	20-90 %
Casing material	Polycarbonate
Temperature range [°C]	0-40
Mounting	Wall surface mounting
Ingress protection	IP30
Dimensions [mm]	86x86x30

#### Humidistat wiring diagram

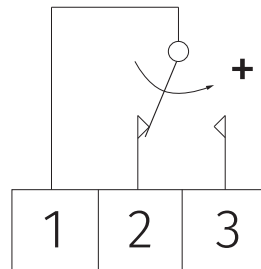

Humidification  
Dehumidification

Closing contact between terminals 1 and 2  
Closing contact between terminals 1 and 3

ELECTRIC ACTUATORS

Series  
**BELIMO**  
**TF24/TF230**



■ **Application**

The TF series actuators with actuating torque 2 Nm are designed for controlling air dampers with cross section up to 0.4 m<sup>2</sup> installed in various ventilation and air conditioning systems and performing protection functions, as freezing protection, smoke detection, etc.

■ **Design**

The actuator moves the damper to its operating position while tensioning the return spring at the same time. In case of power supply cut-off, the damper moves back to its safe position by the spring energy. The actuator is installed directly on the damper axis and locked with a special spindle clamp to prevent its turning-through. The actuator overload protection stops the actuator once it reaches the end positions. The turning angle may be adjusted by a mechanical end stop.

**Technical data**

	<b>TF24</b>	<b>TF230</b>
Voltage	24 AC 50/60 Hz, 24 DC	230 V~50/60 Hz
Nominal voltage range [V]	19.2...28.8 AC 21.6...28.8 DC	85...265 AC
Rated power [VA]	4 ( max. I 5.8 A at t = 5 ms)	4 (max. I 150 mA at t = 10 ms)
Power consumption in operation/at rest [W]	2/1.3	2/ 1.3
Connecting cable	1 m long, 2 x 0.75 mm <sup>2</sup>	
Rotation direction	determined by L/R positioning	
Torque (motor/spring) [Nm]	2, nominal voltage/2	
Rotation angle:	max. 95°, adjustable 37...100 % with a mechanical end stop	
Running time (motor/spring) [s]	40...75 (0...2 Nm)/< 25 at -20...50 °C	
Service life	60 000 switching operations	
Ingress protection	IP42	
Electrical protection class	III low voltage II totally insulated	
Operation temperature [°C]	-30...+50	
Storage temperature [°C]	-40...+80	
Ambient humidity	95 %, no condensation	
Noise level (motor/ spring) [dBA]	50 /~62	
Maintenance	not required	
Mass [kg]	0.6	

**Wiring diagram**

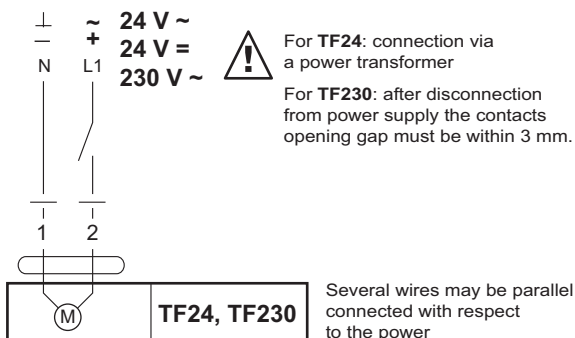

**Overall dimensions [mm]**

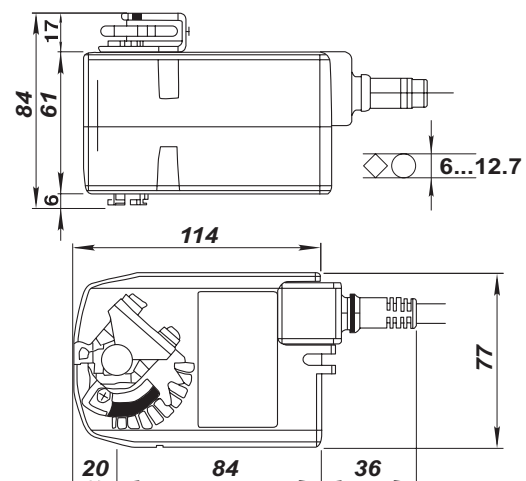

Duct temperature sensors with a terminal box

**KDT-MK**

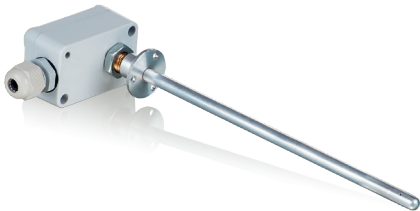

■ **Application**

The duct temperature sensors are designed for installation in the air duct and temperature measurement of the air flow in the ventilation and air conditioning systems.

■ **Design**

The sensing element, NTC thermometer resistor, is enclosed in the aluminium sleeve. The thermometer resistor electric resistor depends on the temperature, the non-linear resistance. Connection of the sensor to the controller is double-wired, regardless of polarity.

The KDT-MK sensor delivery set includes a mounting flange with a fixing screw for its fixation to the air duct wall.

The sensors are supplied with a 2.5 m connecting cable. The immersion depth is adjusted for 100, 150, 200 or 400 mm.

■ **Mounting**

Fixation with screws to the air duct wall by means of the flange with the sensing element located the air stream.

**Technical data**

	<b>KDT-MK</b>
Temperature measuring range [°C]	-30...+60
Voltage [V]	≤ 5 DC *
Output	resistance
Electric connection	double-wire, cross section 2x0.25 mm <sup>2</sup>
Relative humidity	up to 90 %, no condensation
Protection rating	IP54
Electrical appliance class	III

\*Maximum current generated through the sensor by the applied voltage is 2 mA.

**Overall dimensions:**

Type	L [mm]
KDT-MK 100	100
KDT-MK 150	150
KDT-MK 200	200
KDT-MK 400	400

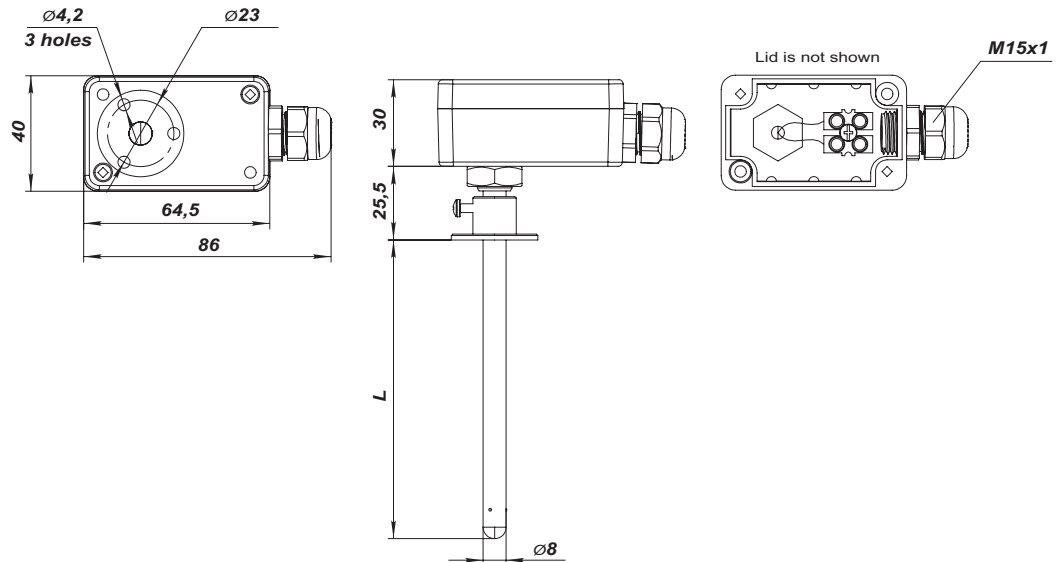

## Duct temperature sensors with a terminal box KDT2-MK

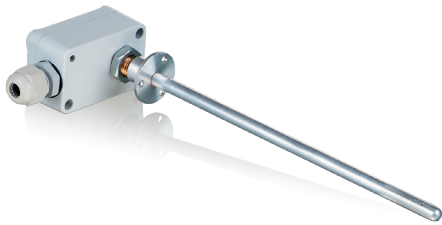

### Application

The duct temperature sensors are designed for installation in the air duct and temperature measurement of the air flow in the ventilation and air conditioning systems.

### Design

The sensor consists of the integrated circuit chip located inside the plastic casing. This sensor type has a linear transfer characteristics of output voltage to temperature and a three-wire connection to power mains.

This sensor type is not compatible with resistance

sensors. During electric connections the polarity of the outputs connected to the inputs of the air handling units must be considered.

The KDT2-MK sensor delivery set includes a mounting flange with a fixing screw for its fixation to the air duct wall. The sensors are supplied with a 2.5 m connecting cable. The immersion depth is adjusted for 100, 150, 200 or 400 mm.

### Mounting

Fixation with screws to the air duct wall by means of the flange with the sensing element located the air stream.

### Technical data

	KDT2-MK
Temperature measuring range [°C]	-30...+60
Voltage [V]	2.7...10
Output resistance [Ohm]	800
Electric connection	three-wire, cross section 3x0.25 mm <sup>2</sup>
Relative humidity	up to 90 %, no condensation
Protection rating	IP54
Electrical appliance class	III

### Overall dimensions:

Type	L [mm]
KDT2-MK 100	100
KDT2-MK 150	150
KDT2-MK 200	200
KDT2-MK 400	400

### Wiring diagram

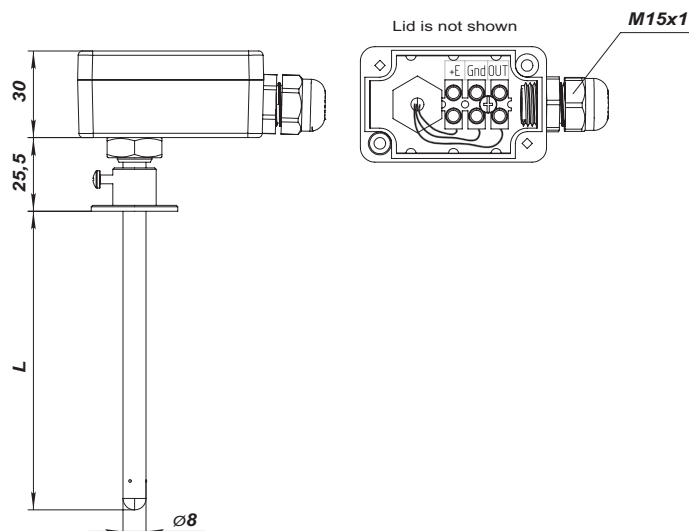
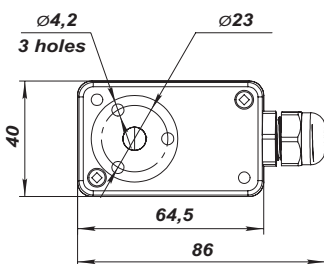
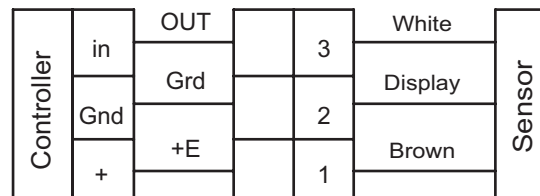

CO<sub>2</sub> sensor  
**CO2-1**



CO<sub>2</sub> sensor  
**CO2-2**



■ **Application**

The sensor is designed for indoor carbon dioxide concentration measurement and respective air flow regulation through the control output signal to the fan. Air flow control based on CO<sub>2</sub> concentration is an efficient energy saving solution.

■ **Design and compatibility**

The sensor has two separate outputs: a normally opened dry relay contact and an analogue output 0...10 V (this output is adjustable for 2...10 V/0...20 mA/4...20 mA).

■ **Modifications**

The sensor is available in two modifications: CO2-1 and CO2-2. The CO2-1 model incorporates LED lights for CO<sub>2</sub> concentration and operation buttons indicating the level of three operation modes.

■ **Mounting and power supply**

The sensor is designed for wall surface mounting. 24 VAC low current power supply. If power supply 24 V is not available, connect the TRF plug that is offered as an accessory.

■ **Accessories**

Power supply unit is applied for connection of the sensor to 220 V (model **TRF-220/24-1.6**) or 120 V (**TRF-120/24-1.6**) AC power mains.



**Technical data**

	Parameters	Value
Power supply/consumption		24 VAC (50/60 Hz ± 10 %), 24 VDC/1.6 W Max
Gas detection analyzer		Non-dispersive infrared detector (NDIR) with self-calibration system
CO <sub>2</sub> measuring range		0–2.000 ppm (parts per million)
Accuracy at 25 °C, 2.000 ppm		±30 ppm + 3 % of reading
Response time		max. 2 min
Warm up time for each turning-on		2 hours (first time), 2 minutes (operation)
Analogue output		0–10VDC (default), 4–20mA selectable by jumpers
On/Off output		1X2A switch load Four set points selectable by jumpers
6 LED lights for CO <sub>2</sub> concentration indication (for model CO2-1)		1st green indicator lights when CO <sub>2</sub> concentration is below 600 ppm; 1st and 2nd green indicators light when CO <sub>2</sub> concentration is 600–800 ppm; 1st yellow indicator lights when CO <sub>2</sub> concentration is 800–1200 ppm; 1st and 2nd yellow indicators light when CO <sub>2</sub> concentration is 1200–1400 ppm; 1st red indicator lights when CO <sub>2</sub> concentration is 1400–1600 ppm; 1st and 2nd red indicators light when CO <sub>2</sub> concentration is above 1600 ppm
Operating conditions/storage recommendations		0–50 °C; 0–95 % RH non condensing/0–50 °C
Mass/Dimensions		0.120 kg/100 mm x 80 mm x 30 mm

CO<sub>2</sub> SENSORS

CO<sub>2</sub> sensor  
**CO2-3**

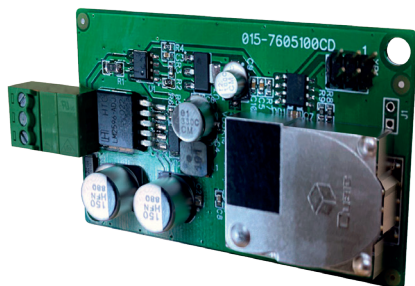

**Technical data**

	Parameters	Value
Power supply voltage		24 VAC./DC (±10%)
Power consumption		< 1.5 W/24 V DC in standard conditions; < 2.9 VA/24 V AC in standard conditions; 200 mA peak current
Carbon dioxide sensor		Optical nondispersive infrared (NDIR) sensor with automatic calibration
CO <sub>2</sub> measuring range		0...2000 mln-1
CO <sub>2</sub> output		0 - 10 V
CO <sub>2</sub> measurement error		± 30 mln-1 and ± 3 % of the measured value
Service life of the sensitive element		15 years
Gas exchange		Diffusion
Ambient temperature		0...+50 °C
Humidity		0-95 % RH without condensation
Time for entering the operating mode		Approx. 1 hour
Time for first data reading		< 2 minutes
Electrical connection		0.14–1.5 mm <sup>2</sup> by screw clamps
Dimensions LxWxH		76x40x15 mm

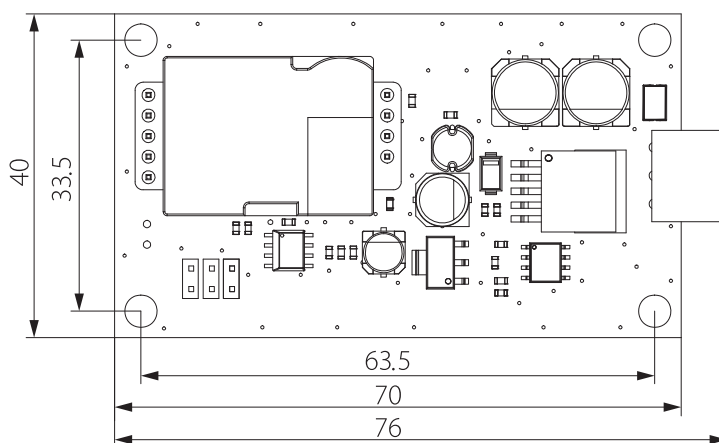

**■ Mounting**

The sensor is installed inside the unit in the exhaust air duct after the filter up to the heat exchanger.

## ventilation systems

[www.ventilation-system.com](http://www.ventilation-system.com)

**VENTS reserves the rights to modify any of its products' features, designs, components and specifications at any time and without notice to maintain the development and quality of manufactured goods.**

2026-03



**HVI**  
MEMBER



CORRESPONDING MEMBER  
**EUROVENT**