

# USER'S MANUAL

---

## A37 (KVENT Medium)



Automatic control system for AirVents

---

## CONTENTS

|                                      |    |
|--------------------------------------|----|
| Safety requirements.....             | 2  |
| Purpose.....                         | 3  |
| A37 (kvent medium) control unit..... | 4  |
| Wiring.....                          | 7  |
| Technical data.....                  | 11 |
| Installation and set-up.....         | 12 |
| Control .....                        | 15 |

This user's manual is a main operating document intended for technical, maintenance, and operating staff.

The manual contains information about purpose, technical details, operating principle, design, and installation of the A37 unit and all its modifications.

Technical and maintenance staff must have theoretical and practical training in the field of ventilation systems and should be able to work in accordance with workplace safety rules as well as construction norms and standards applicable in the territory of the country.

## SAFETY REQUIREMENTS

All operations described in this manual must be performed by qualified personnel only, properly trained and qualified to install, make electrical connections and maintain ventilation units.

Do not attempt to install the product, connect it to the mains, or perform maintenance yourself.

This is unsafe and impossible without special knowledge.

Disconnect the power supply prior to any operations with the unit.

All user's manual requirements as well as the provisions of all the applicable local and national construction, electrical, and technical norms and standards must be observed when installing and operating the unit.

Disconnect the unit from the power supply prior to any connection, servicing, maintenance, and repair operations.

While mounting the unit, avoid compression of the casing!

Misuse of the unit and any unauthorised modifications are not allowed.

Do not expose the unit to adverse atmospheric agents (rain, sun, etc.).

Do not use the unit in a hazardous or explosive environment containing spirits, gasoline, insecticides, etc.

Do not sit on the unit and do not put objects on it.

The information in this user's manual was correct at the time of the document's preparation. The Company reserves the right to modify the technical characteristics, design, or configuration of its products at any time in order to incorporate the latest technological developments.

Never touch the unit with wet or damp hands.

Never touch the unit when barefoot.

**BEFORE INSTALLING ADDITIONAL EXTERNAL DEVICES, READ THE APPROPRIATE USER MANUALS.**



**THE PRODUCT MUST BE DISPOSED SEPARATELY AT THE END OF ITS SERVICE LIFE.**

**DO NOT DISPOSE THE UNIT AS UNSORTED DOMESTIC WASTE.**

## PURPOSE

The automatic control system is designed to control a range of different ventilation system configurations.

Control of different basic system elements, such as supply and exhaust fans, heat exchanger, air heater, cooler, air dampers is implemented.

The automatic control system does not provide for control of the electric air preheater, filters (no more than two per unit, one for supply air and one for exhaust air), reversible water heat exchanger, or rotary heat exchanger with frequency converter.

The automated unit includes a configurable controller with pre-installed software.

The controller can be configured for a custom layout of the ventilation system.

The panels are rated for continuous operation.

**The functionality of the automatic control system is described in detail in the controller's user manual**

**Contact the unit supplier to receive the controller's user manual.**

**A37 (KVENT MEDIUM) CONTROL UNIT**

**Control unit  
(general layout)**

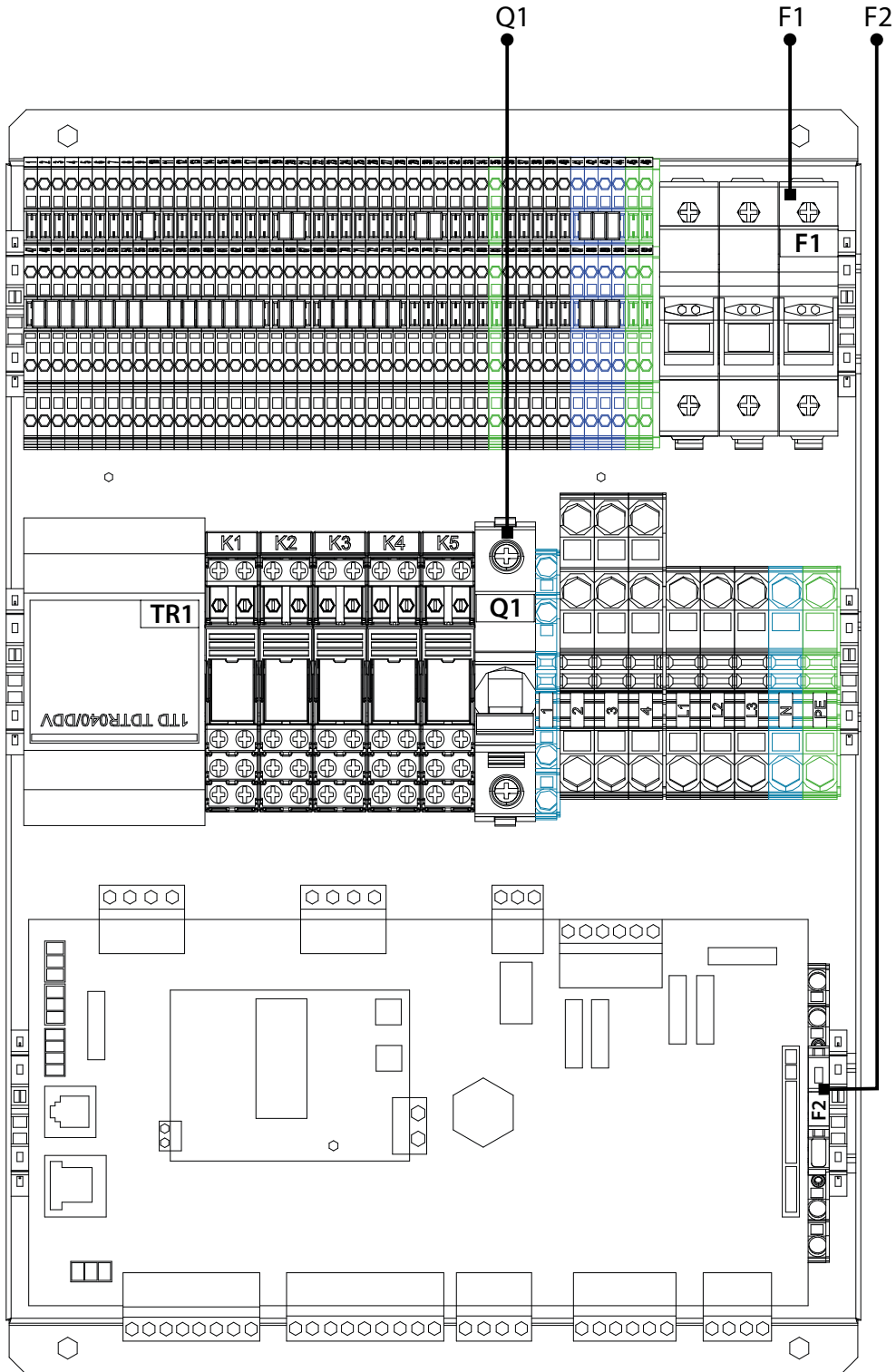

| Designation | Function   | Value |
|-------------|--|-------|
| F1          | Supply and exhaust fans' power supply protection                     | *     |
| F2          | Controller, sensors' and actuators' 24 VAC power supply protection   | 3.15A |
| Q1          | Power supply protection of the 230 VAC digital outputs and actuators | 16A   |

\*The value is determined by the total current of the supply and extract fans delivered with the unit

| Fan motor      | Electr. parameters     | Circ. Breaker |
|----------------|------------------------|---------------|
| BL-B250E-EC01  | 230 VAC, 532 W, 2.4 A  | 6A            |
| R3G250-PR04-H1 | 230 VAC, 500 W, 2.3 A  |               |
| BL-B310E-EC05  | 230 VAC, 700 W, 3.1 A  | 8A            |
| R3G310-RS01-H1 | 230 VAC, 730 W, 3.2 A  |               |
| R3G355RJ7501   | 400 VAC, 1100 W, 1.7 A | 6A            |
| BY-B355E-EC-05 | 400 VAC, 1100 W, 1.7 A |               |
| R3G500RL9601   | 400 VAC, 1320 W, 2.1 A |               |
| R3G500-RA28-02 | 400 VAC, 3600 W, 3.9 A | 10A           |

### Replacement table of fuses and their analogs for 24 VAC controller, sensors and actuators power supply

| Rated current [A]            | 3,15        |                |         |
|------------------------------|-------------|----------------|---------|
| Manufacturing factory        | LITTELFUSE  | EATON/BUSSMANN | ESKA    |
| Equipment code               | 02183.15MXP | BK1-S506-3-15- | 522.522 |
| Breaking current             | 35A         |                |         |
| Circuit breaker size         | 5x20mm      |                |         |
| Circ. breaker characteristic | Slow        |                |         |

### Replacement table of fuses and their analogs for fan motor protection

| Rated current [A]            | 6       |             |
|------------------------------|---------|-------------|
| Manufacturing factory        | ETI     | DF ELECTRIC |
| Equipment code               | 2651004 | 420506      |
| Breaking current             | 20 kA   | 20 kA       |
| Circuit breaker size         | 8x32 mm | 8x31 mm     |
| Circ. breaker characteristic | gG      |             |

| Rated current [A]            | 8       |             |
|------------------------------|---------|-------------|
| Manufacturing factory        | ETI     | DF ELECTRIC |
| Equipment code               | 2651005 | 420508      |
| Breaking current             | 20 kA   | 20 kA       |
| Circuit breaker size         | 8x32 mm | 8x31 mm     |
| Circ. breaker characteristic | gG      |             |

| Rated current [A]            | 10      |             |
|------------------------------|---------|-------------|
| Manufacturing factory        | ETI     | DF ELECTRIC |
| Equipment code               | 2651006 | 420510      |
| Breaking current             | 20 kA   | 20 kA       |
| Circuit breaker size         | 8x32 mm | 8x31 mm     |
| Circ. breaker characteristic | gG      |             |

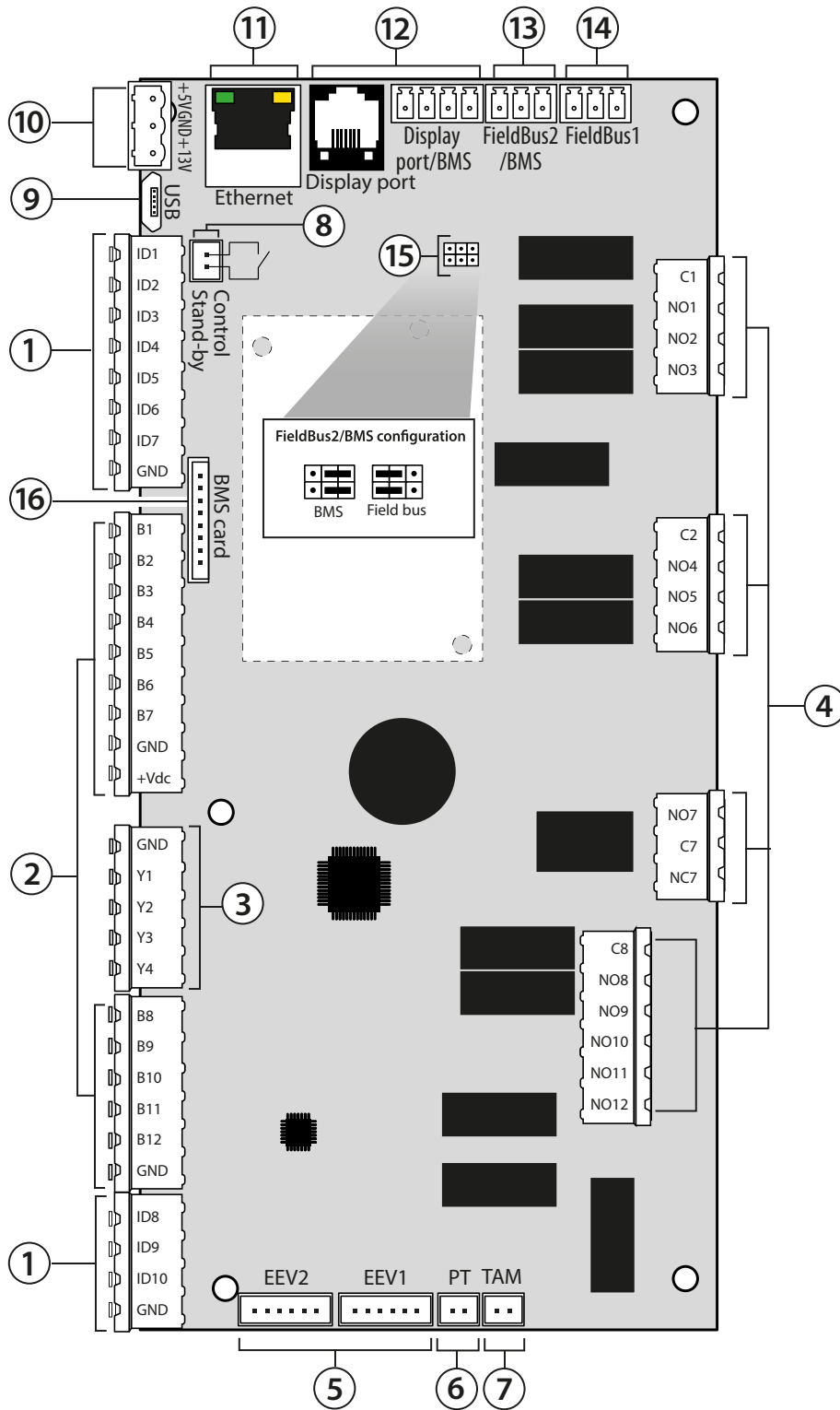

| Item | Description                | Item | Description  |
|------|----------------------------|------|--|
| 1    | Digital inputs             | 9    | Micro USB to update applications, import and export settings and error log |
| 2    | Analog inputs              | 10   | Power supply for external sensors  |
| 3    | Analog outputs             | 11   | Ethernet port  |
| 4    | Digital outputs            | 12   | Display port. It is also used for pGDx connection                          |
| 5    | Expansion valve control    | 13   | BMS/Fieldbus2 port   |
| 6    | Voltage input              | 14   | BMS/Fieldbus1 port. It is also used for th-Tune connection                 |
| 7    | Current input              | 15   | Jumpers for the BMS/Fieldbus2 port configuration                           |
| 8    | Standby mode control input | 16   | BMS card (not included in the delivery set; ordered separately) connector  |

## WIRING



**DISCONNECT THE POWER SUPPLY PRIOR TO ANY OPERATIONS WITH THE UNIT.  
THE UNIT MUST BE CONNECTED TO POWER MAINS BY A QUALIFIED ELECTRICIAN.**



**ANY TAMPERING WITH THE INTERNAL CONNECTIONS IS PROHIBITED  
AND WILL VOID THE WARRANTY.**



**DO NOT LAY THE CABLE IN CLOSE PROXIMITY  
AND PARALLEL TO THE CONTROL PANEL CABLE!!  
DO NOT COIL THE CONTROL CABLE IN LOOPS WHILE LAYING IT.**



**IT IS RECOMMENDED TO CHECK THE TIGHTNESS OF SCREW CLAMPS ON ELECTRICAL  
CONTACT CONNECTIONS EVERY SIX MONTHS AND TIGHTEN THEM IF NECESSARY**

The unit is rated for connection to power mains according to the wiring diagram.

The connection must be made using durable, insulated and heat-resistant conductors (cables, wires). Conductor selection must be based on the maximum load current, maximum conductor temperature depending on the wire type, insulation, length and installation method.

**To protect the power supply of the control unit, it is necessary to equip it with an automatic circuit breaker with a rated breaking current greater than or equal to the total current of all the loads in the unit's circuit.**

The circuit breaker and the disconnecter are not included in the delivery set.

The cables must only be wired through the cable glands on the product.

External wiring diagram.

Unit equipped with single-phase fans and an electric heating elements section up to 5.1 kW (may not be included)

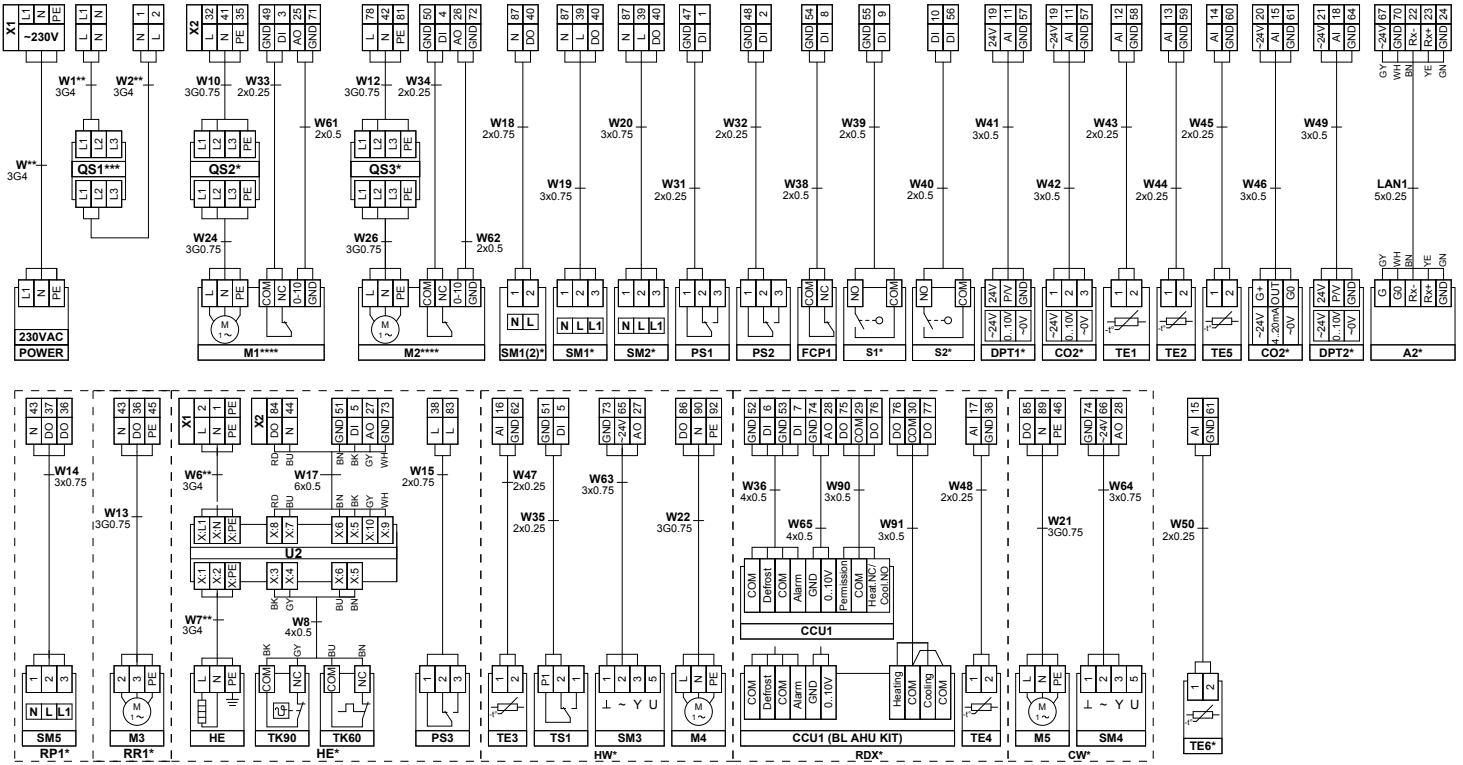

- \* Devices to be connected based on the order
- \*\* Provided that a 5.1 kW electric heating section is connected
- \*\*\* If there is no three-pole load-break switch, a jumper of the corresponding cross-section must be installed instead
- \*\*\*\* If the fan motor has a tacho output, a DTV500-OEM differential pressure relay is to be used to receive the "Alarm" signal

External wiring diagram.

Unit equipped with single-phase fans and an electric heating elements section up to 12 kW

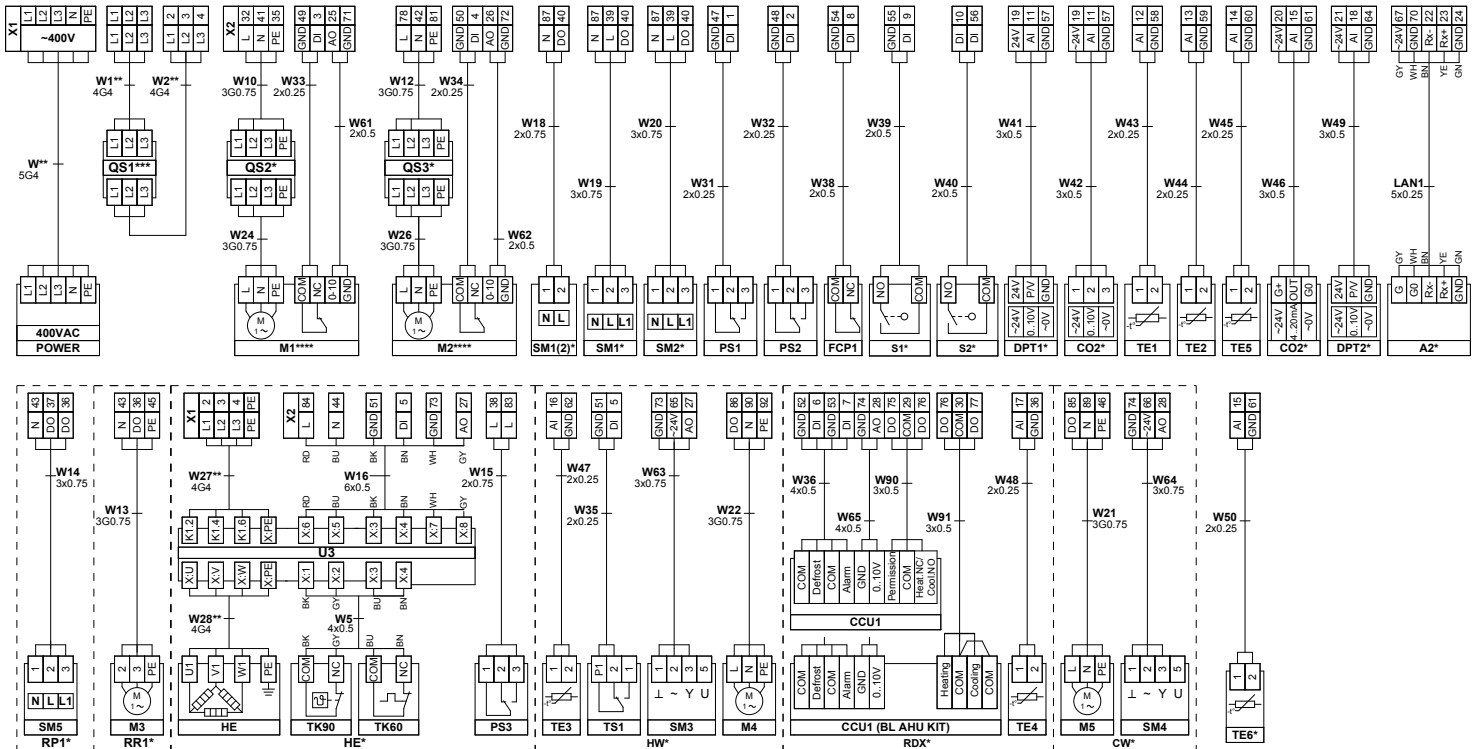

- \* Devices to be connected based on the order
- \*\* Provided that a 12 kW electric heating section is connected
- \*\*\* If there is no three-pole load-break switch, a jumper of the corresponding cross-section must be installed instead
- \*\*\*\* If the fan motor has a tacho output, a DTV500-OEM differential pressure relay is to be used to receive the "Alarm" signal

### External wiring diagram.

Unit equipped with three-phase fans and an electric heating elements section up to 30 kW (may not be included)

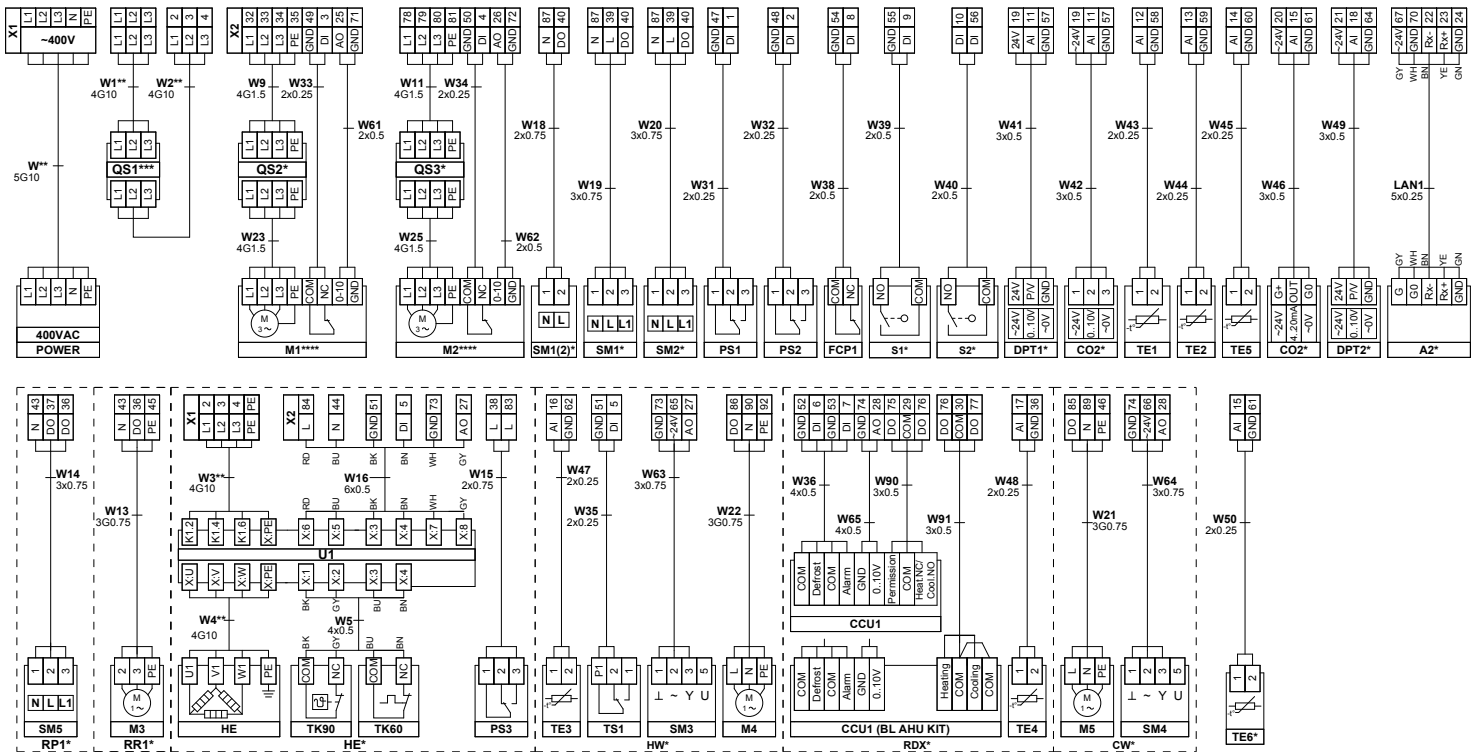

\* Devices to be connected based on the order

\*\* Provided that a 30 kW electric heating section is connected

\*\*\* If there is no three-pole load-break switch, a jumper of the corresponding cross-section must be installed instead

\*\*\*\* If the fan motor has a tachometer output, a DTV500-OEM differential pressure relay is to be used to receive the "Alarm" signal

**External wiring diagram designation key**

| <b>General equipment</b> |   |
|--------------------------|---|
| <b>Designation</b>       | <b>Name</b>                                     |
| A2                       | Control panel                                   |
| CO2                      | Inline CO <sub>2</sub> sensor                   |
| DPT1, DPT2               | CAV / VAV sensor                                |
| FCP1                     | Fire alarm (customer's equipment)               |
| M1                       | Supply air fan                                  |
| M2                       | Extract air fan                                 |
| QS1                      | Three-pole load-break                           |
| S1, S2                   | Door limit switch                               |
| PS1                      | Supply air filter differential pressure switch  |
| PS2                      | Extract air filter differential pressure switch |
| SM1                      | Supply air damper actuator                      |
| SM2                      | Exhaust air damper actuator                     |
| SM1(2)                   | Air damper actuator (common)                    |
| TE1                      | Intake air temperature                          |
| TE2                      | Extract air temperature                         |
| TE5                      | Supply air temperature in the duct              |
| TE6                      | Exhaust air temperature                         |

| <b>Additional equipment based on the order</b> |   |
|--|---|
| <b>Designation</b>                             | <b>Name</b>   |
| <b>Plate heat exchanger (RP1)</b>              |   |
| SM5  | Air damper actuator on the heat exchanger   |
| <b>Rotary heat exchanger (RR1)</b>             |   |
| M3   | Rotor motor   |
| <b>Electric heating (HE)</b>                   |   |
| PS3  | Differential pressure switch on the supply air fan (protection)                                     |
| TK60   | Self-resetting thermal switch 60°C.   |
| TK90   | Button-driven thermal switch 60°C   |
| U1(2)(3)                                       | Heating power control board based on the section of electric heating elements installed in the unit |
| <b>Water heating section (HW)</b>              |   |
| TE3  | Heating temperature of the back water flow  |
| TS1  | Water heater frost protection   |
| SM3  | Three-way heating valve actuator  |
| M4   | Heating circulation pump  |
| <b>RDX (reverse) heat exchanger section</b>    |   |
| CCU1   | Compressor and condenser unit   |
| TE4  | Temperature upstream the compressor and condenser unit  |
| <b>Water cooling section (CW)</b>              |   |
| M5   | Cooling circulation pump  |
| SM4  | Three-way cooling valve actuator  |

## TECHNICAL DATA

### Technical parameters

| Parameter                  | pGDx Touch 4.3" (A29/A49)   | th-Tune (A30/A38)                 | pGNE (A32/A39)  |
|----------------------------|---|-----------------------------------|---|
| Storage temperature [°C]   | -30...+70   | -20...+70                         | -20...+70   |
| Storage humidity [%]       | 10...85 @40 (no condensation)   | 10...90 (no condensation)         | 10...90 (no condensation)   |
| Operation temperature [°C] | 0...+50   | -10...+60                         | -20...+60   |
| Operation humidity [%]     | 10...85 @40 (no condensation)   | 10...90 (no condensation)         | 10...90 (no condensation)   |
| Cable*                     | 6-wire phone cable up to 10 m long;<br>Power consumption, no more than 3 W. | AWG 20 or AWG 22 up to 500 m long | Phone cable up to 50 m long; AWG 22 twisted pair up to 500 m long |
| Ingress protection rating  | IP20  | IP20                              | IP40  |

\* Included in the delivery set.

### Overall dimensions of the pGDx controller

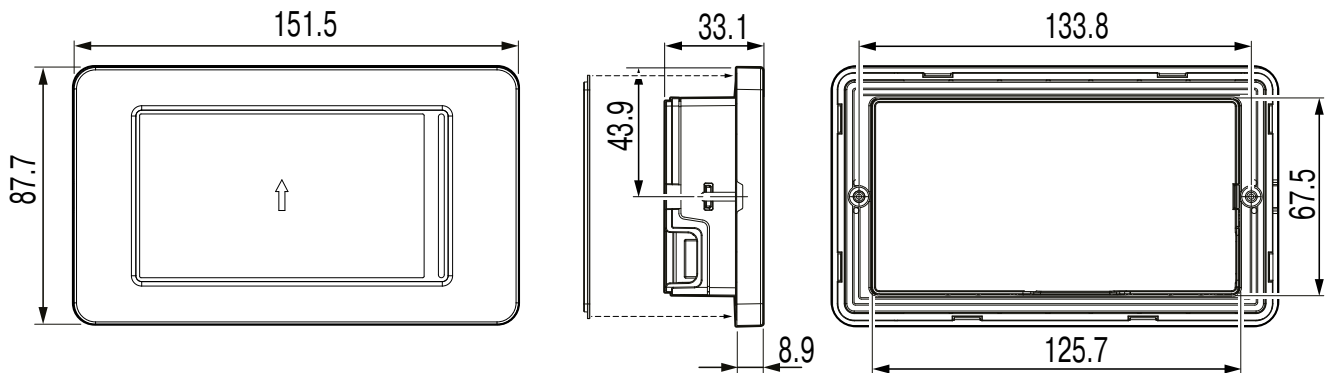

### Overall dimensions of the thTune controller

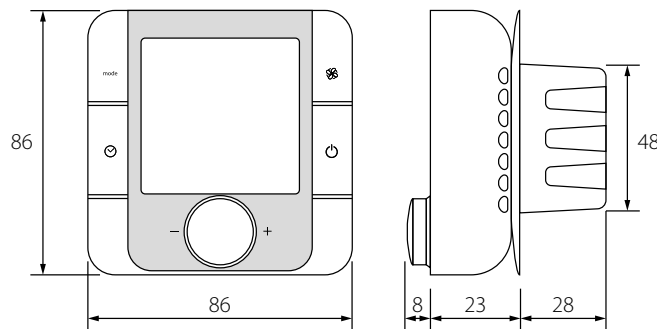

### Overall dimensions of the pGNE controller

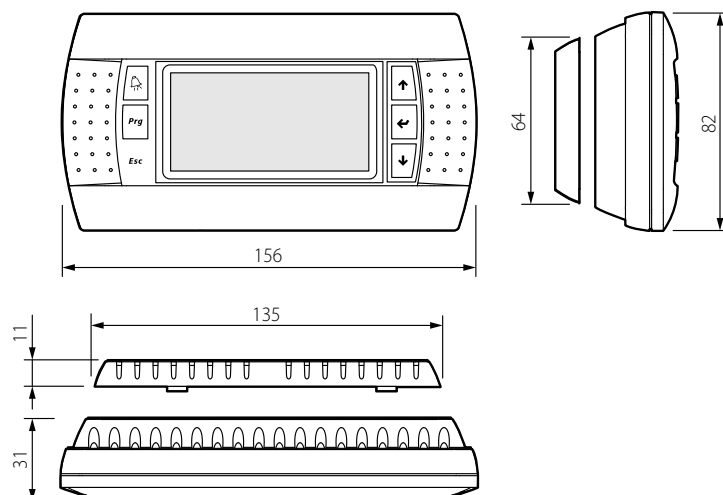

**INSTALLATION AND SET-UP**

**INSTALLATION OF THE PGDX CONTROL PANEL**

To mount the control panel in a wall partition, prepare the cutout and openings as shown in the picture below.

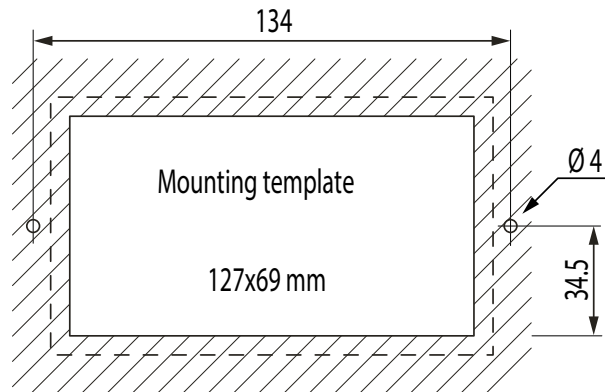

Use screws to secure the control panel in the partition and install the frame. The frame should click into place when closed.

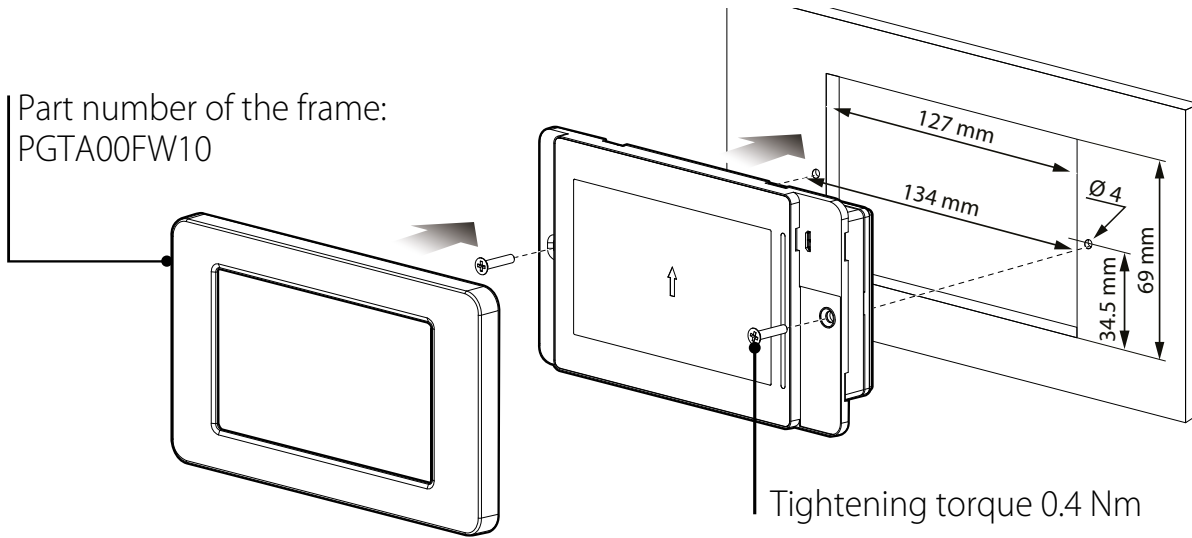

Connection to the controller

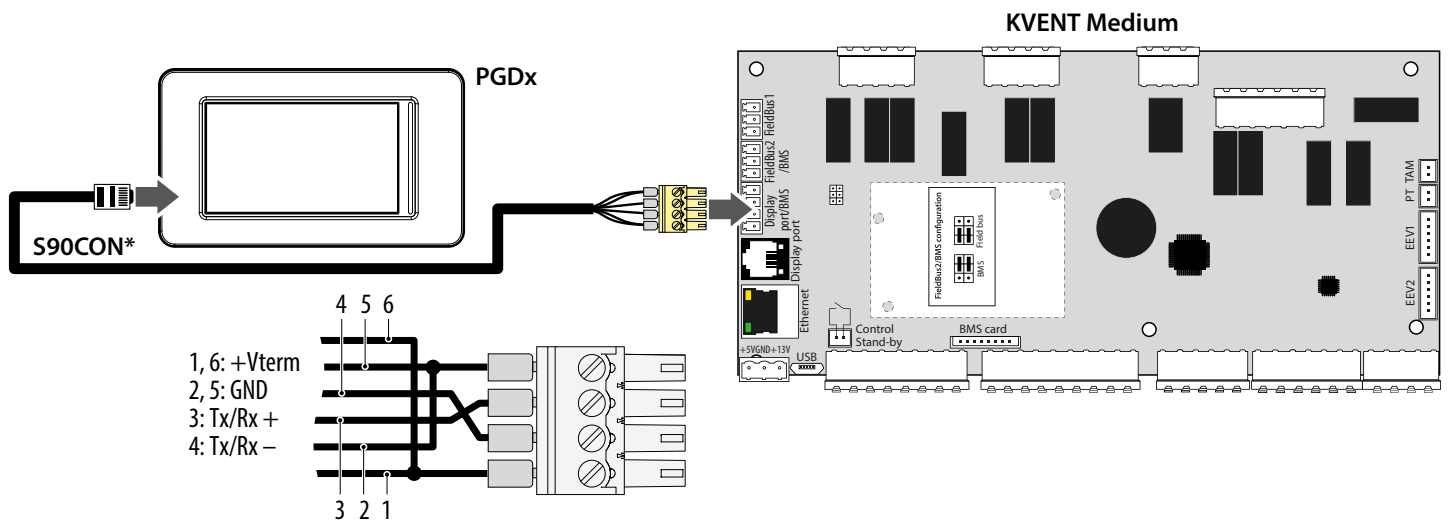

### Installation of the th-Tune control panel

Use a mounting box of at least 65 mm in diameter and at least 31 mm deep to install the back side of the panel.

1. Use a screwdriver to separate the front and back sides of the control panel.
2. Disconnect the 4-pin connector from the front side of the control panel.

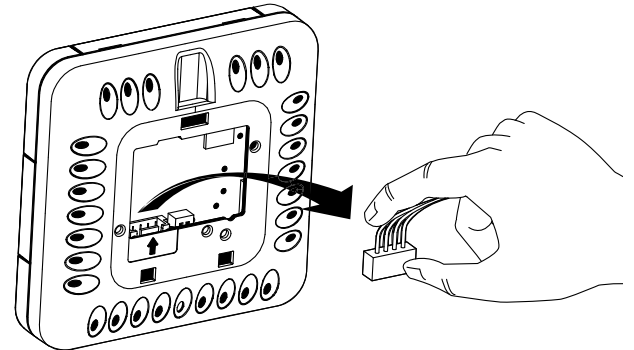
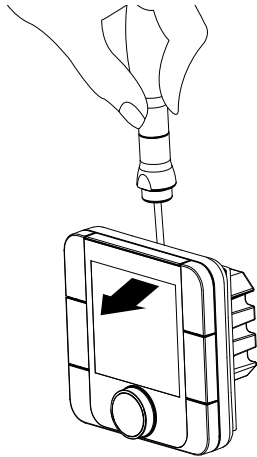

3. Complete the wiring as shown in the external wiring diagram.
4. Secure the back side of the control panel in the mounting box using the supplied screws.
5. Connect the 4-pin connector again.
6. Route all the cables inside the control panel starting bottom-to-top and install the control panel. The panel should click into place when closed.

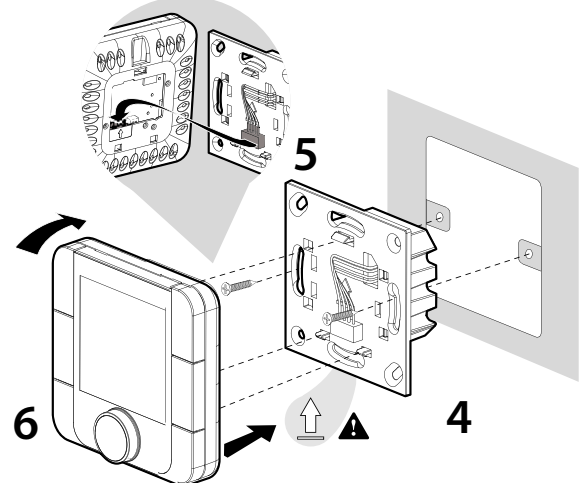
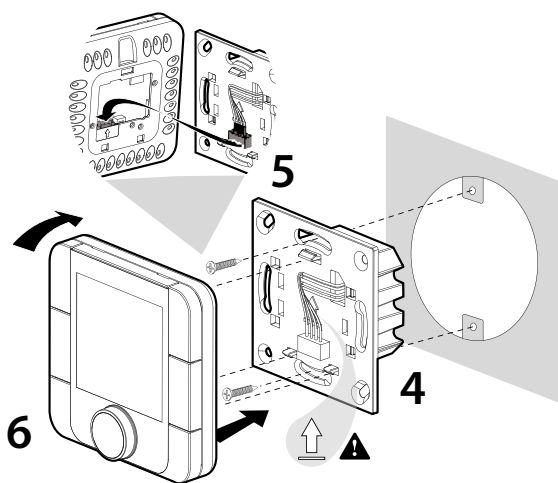

#### Overall dimensions of the control panel [mm]

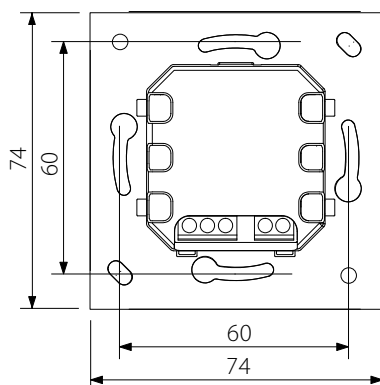

The scheme drawing of the back part of the control panel is shown on the left.

### INSTALLATION OF THE PGNE CONTROL PANEL

Connect the pGNEcontrol panel to the controller using the 6P6C phone connector (PLUG-6P6C-P-C2). The maximum telephone cable length is 50 m.

Route the telephone cable to the installation site to install the control panel on the wall.

1. Secure the back side of the casing in the standard box using dome-headed screws from the delivery set.

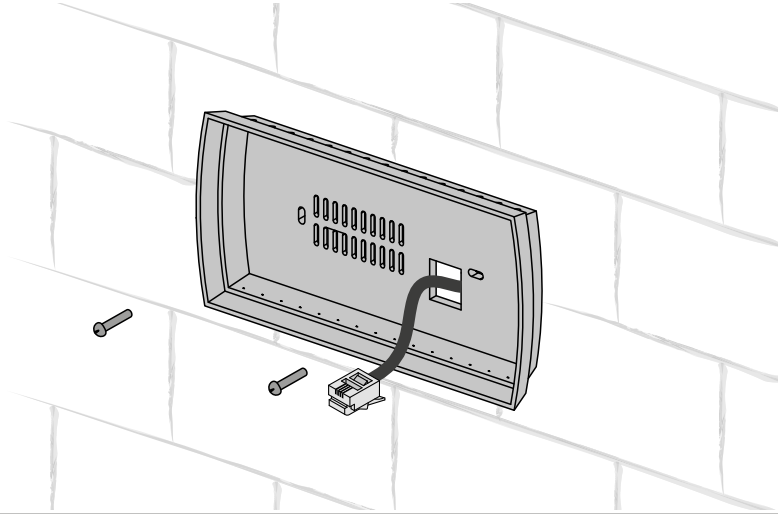

2. Connect the telephone cable to the front part of the control panel. Attach the front side of the control panel to the back side of the casing and secure it using the supplied flat-headed screws as shown in the figure below. Insert the front frame and move it until it clicks into place.

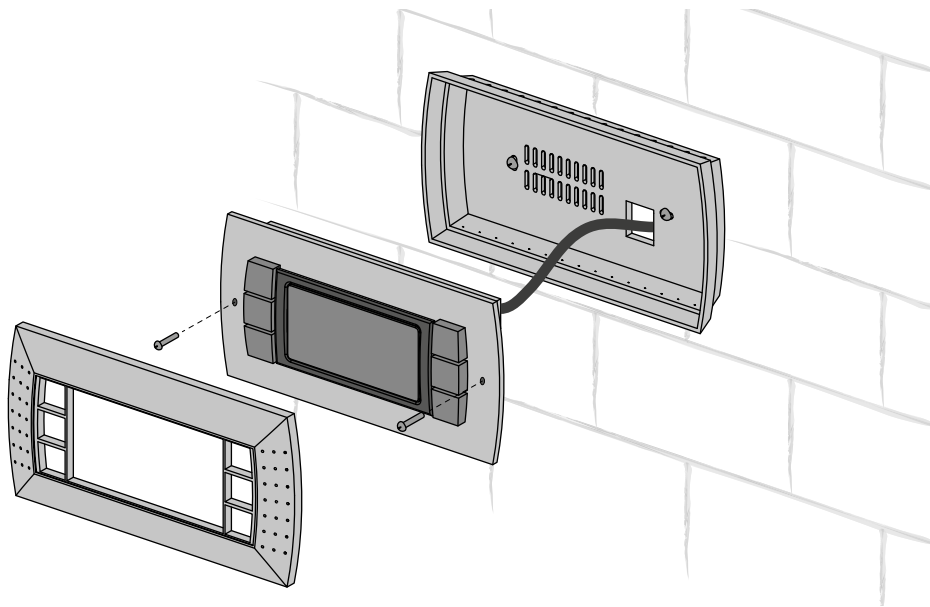

# CONTROL

## pGDx CONTROL PANEL

The starting screen of the ventilation system control system

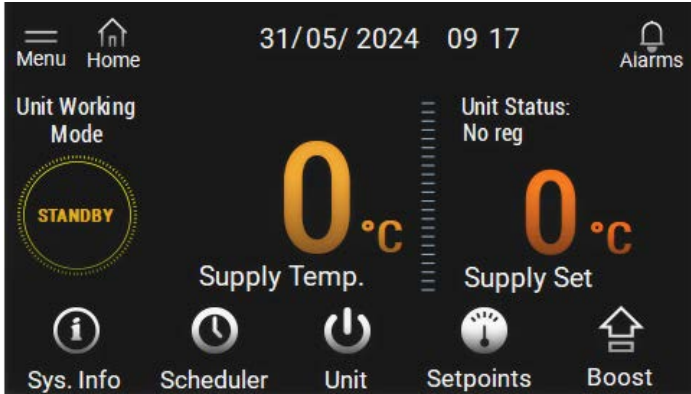

The transition to the information menu about the ventilation system and temperature graphs.

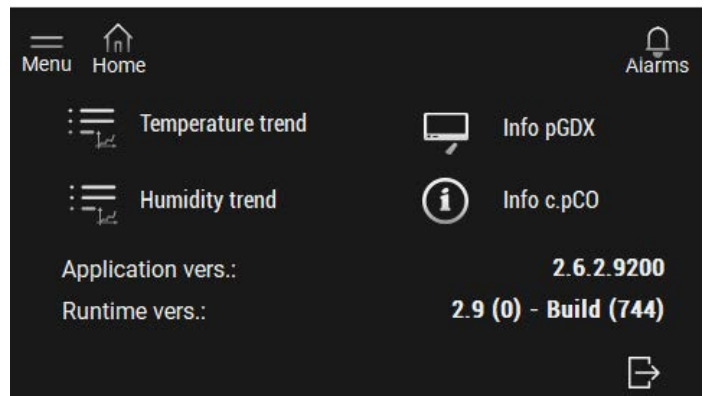

Transition to operation schedule setting menu

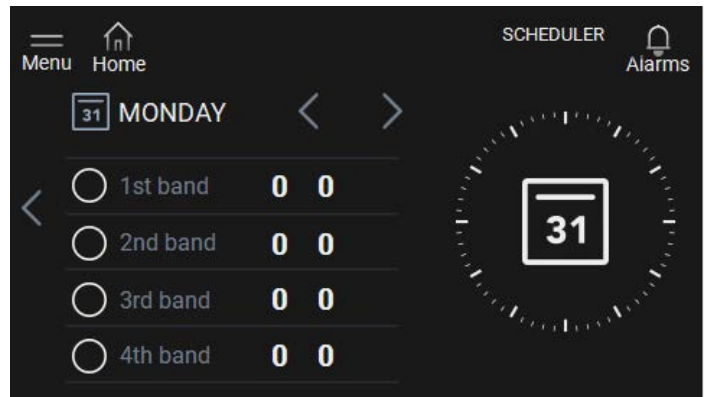
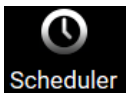

Transition to the ventilation system's operation mode selection menu  
The following modes are available: Off / Standby / Economy / PreComfort / Comfort

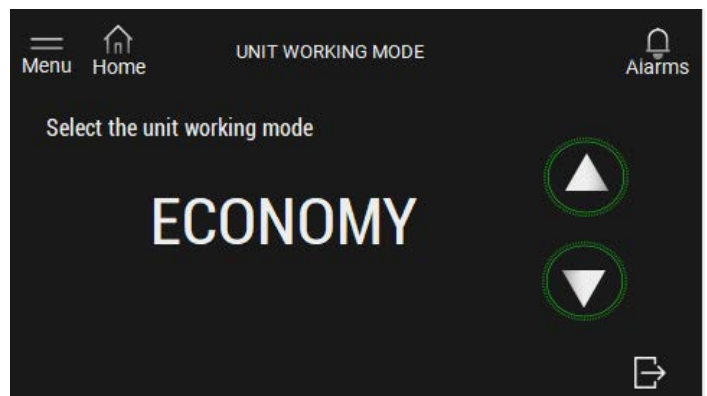

Transition to temperature/humidity setpoint settings

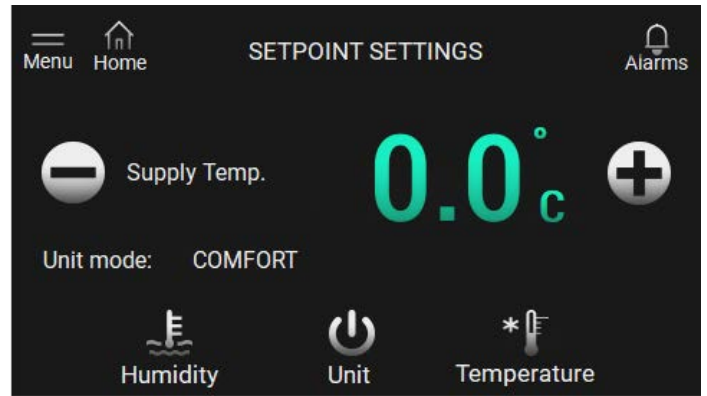

Transition to enabling the Boost function



Transition to current alarms' menu

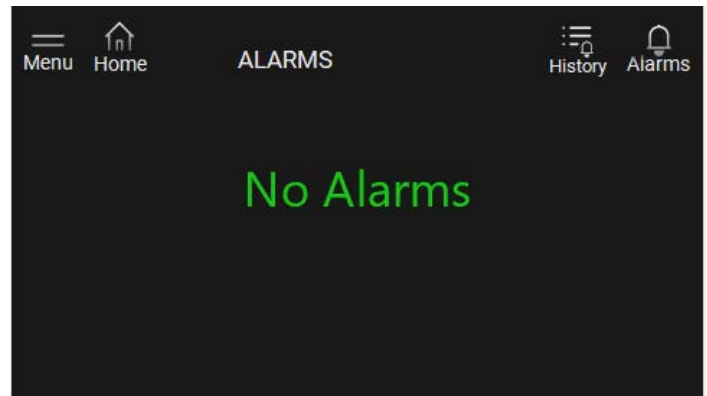

Transition to information and emulator menu of the pGNE controller.  
By default the password is 0000.

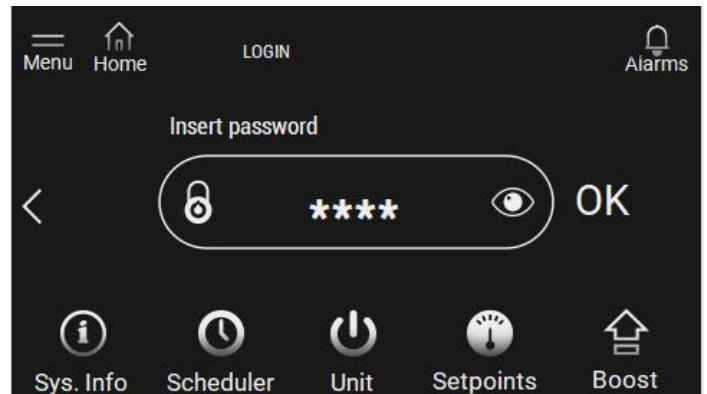
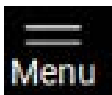

Displays the current status of the ventilation system.







### Th-Tune control panel

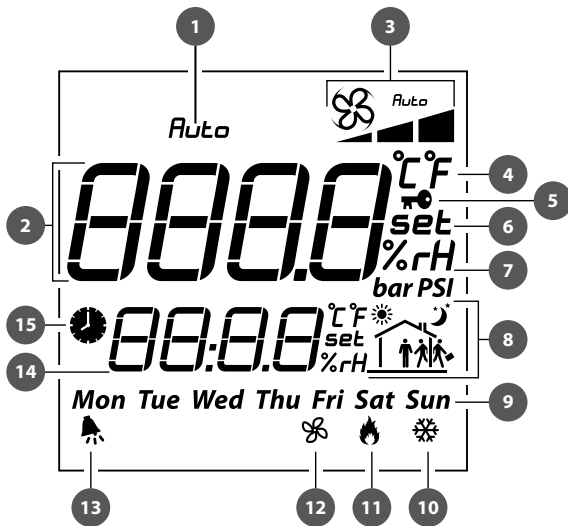

| BUTTON         | FUNCTIONS  |
|----------------|--|
| mode<br>(MODE) | Standby/auto mode. Disables the Boost functions.   |
| <br>(FAN)      | Unit change: ECO, PRECOMFORT, COMFORT, STOP.   |
| <br>(CLOCK)    | To turn the schedule mode on/off: hit the button. To access the schedule menu, press and hold the button for 2 seconds. Use the rotating handle to select options.   |
| MODE+CLOCK     | To turn on the Boost function, press and hold the button for 3 seconds.  |
| <br>(ON-OFF)   | On/off switch. Closes the settings.<br><b>Caution!</b> The on/off switch turns the panel's display on or off and does not influence the unit itself.   |
| <br>(ENCODER)  | Set the desired value by turning the handle. Hit the button once to input the set value of the indoor temperature. Hit the button twice to input the supply air temperature. Hit it three times for the outdoor temperature. |



### DISPLAY SYMBOLS

|     |   |
|-----|---|
| 1.  | System on/off indicator   |
| 2.  | Main field (current indoor temperature, field to input temperature values, schedule input settings etc.)  |
| 3.  | Unit operation modes:<br> ECO<br> PRECOMFORT<br> COMFORT<br> AUTO |
| 4.  | Temperature measurement units   |
| 5.  | Schedule blocking function (the icon will appear when attempting to enable the schedule mode on a non-configured unit)  |
| 6.  | The value being set   |
| 7.  | Humidity measurement units  |
| 8.  | Current timeframe   |
| 9.  | Day of the week   |
| 10. | Cooling mode  |
| 11. | Heating mode  |
| 12. | Ventilation mode  |
| 13. | "Alarm" signal. The alarm code appears in row 14.   |
| 14. | Time  |
| 15. | The schedule mode is on   |

### The description of unit operation modes

**STOP** – the fans are off, the protective functions are operating (the field 3 shows no indication).

**ECO** – the fan speed is low, reduced power consumption and temperature.

**PRECOMFORT** – medium fan speed, temperature and power consumption.

**COMFORT** – maximum fan speed, increased temperature and power consumption.

**AUTO** – unit operation according to the weekly schedule.

To reset the alarm, press and hold both the FAN and ON-OFF buttons simultaneously for 3 seconds.

### Setting up the schedule mode

Th-Tune allows to set up the unit schedule and preset the temperature. To enter the menu, disable the schedule operation mode of the unit and hold the CLOCK button for 2 seconds. The data is stored in the th-Tune, so when switching from the temporary timeframe (hh:mm) to a different one, the starting time is preset to the incremented hour and minute values (hh:mm+1).

Th-Tune checks for the timeframes to match. After entering the schedule menu, the following items drop down:

**Clock** – setting up the current time.

**Sel days** – allows to set up the working schedule and temperature of the unit.

Hit the ENCODER button to move to settings. Then, groups of days or a day can be selected to set up the mode of operation by rotating the ENCODER:

**7 days** (mon, tue, wed, thu, fri, sat, sun). Monday, Tuesday, Wednesday, Thursday, Friday, Saturday and Sunday will have common time settings.

**5 days** (mon, tue, wed, thu, fri). Monday, Tuesday, Wednesday, Thursday, and Friday will have common time settings.

**2 days** (sat, sun). Saturday and Sunday will have common time settings.

**Day by day.** Day-by-day time settings can be set up individually.

Up to 6 timeframes can be selected for each interval. To designate the timeframes, the following icons are used:



Rotate the ENCODER button to switch between timeframe settings.

Each selected timeframe includes such parameters as the set temperature value (1) and activation time (2).

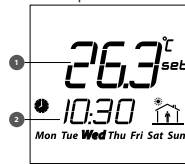

Timeframe settings on display can be disabled "--:--":

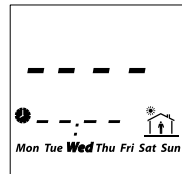

To set up the OFF range on th-Tune, the value can be set to minimum as shown in the figure below.

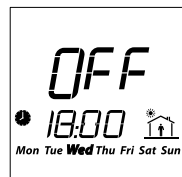

### pGNE control panel





The panel has 6 buttons:

 (ALARM) – to manually reset alarm signals.

**Prg** (PRG) — to change the operating mode.

**Esc** (ESC) — to return to the previous menu screen.

 (UP, DOWN) — to switch between the display screens or increase / decrease values.

 (ENTER) — to confirm the set values and return to the list of parameters.

### RUNNING THE UNIT

When the unit is connected to power mains, the controller boots and displays the main page.

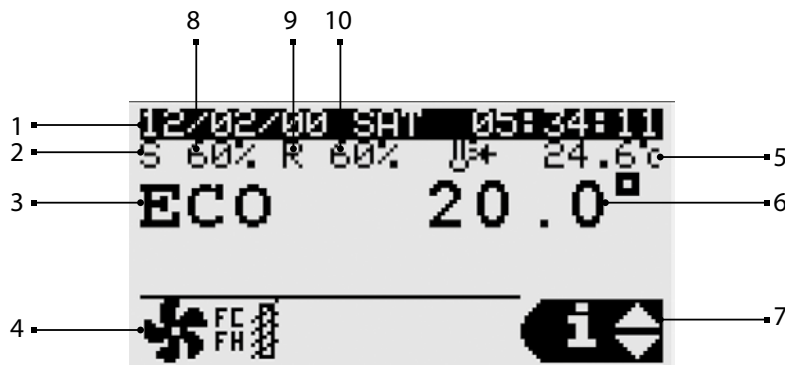

1. Date and time
2. The supply fan is on.
3. Operating mode.  
STOP  
ECONOMY  
PRECOMFORT  
COMFORT  
AUTO
4. Current unit state.

-  — Air dampers open / closed.
-  — Operation of fans.
-  — Heating.
-  — Cooling.
-  — Free heating / cooling.
-  — Humidification.
-  — Drying.
-  — Active recovery.
-  — Normal stop.
-  — Emergency stop.
-  — Active schedule.
-  — Frost protection of the heat exchanger.
-  — Boost activation.

5. Current temperature in the supply air duct.
6. The preset indoor or supply duct temperature setpoint (based on the settings).
7. Indicates access to user menu by means of UP, DOWN and ENTER buttons for confirmation.
  - INFO — displays the general status of devices, physical status of device and sensor inputs and outputs.
  - SET — displays the current set value and schedule-based operating mode. The schedule and devices can be preset.
  - MODE — changing the operation mode of the device (stop, economy, precomfort, comfort, auto).
8. Supply fan speed.
9. The extract fan is on.
10. Extract fan speed.

### Setting up the schedule mode

Press ENTER to move to the SET mode menu.  
The menu has the following 3 setting positions:

- 1) Setting up operation modes for each day of the week. Up to 4 timeframes for operation modes can be set for a single day (mon-sun), as well as the starting time for the set operation mode.

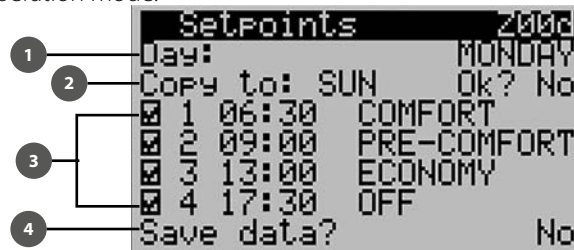

1 – selecting the day of the week to be set up; 2 – the set parameters can be copied onto another day of the week. Select Yes to copy the parameters onto the selected day (the Copy to parameter); 3 – the number of timeframes can be specified for the selected day. The current operation mode is disabled when the next one starts; 4 – saving the set parameters.

- 2) Setting up operation modes for 3 timeframes (ranging from one day to one year). The current operation mode is disabled when the next one starts.

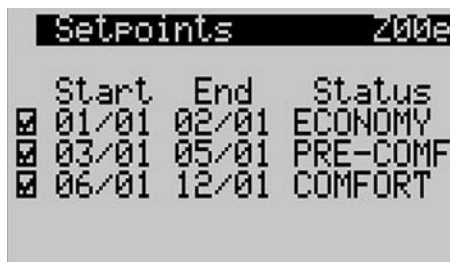

- 3) The transition day to the selected mode can be specified.

Up to 6 transition days can be specified. The current operation mode is disabled when the next one starts.

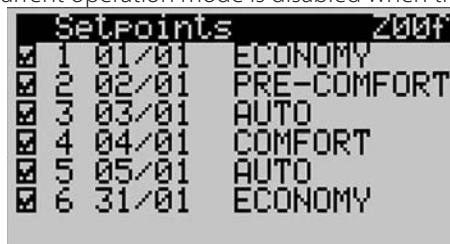

To enable operation by schedule, enter the Unit cfg. tab and set the BOARD parameter to the value I007 Scheduler.



## ALARMS

In case of an alarm, the alarm signal screen is displayed.

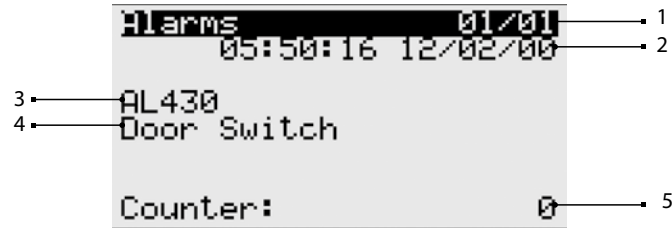

| Item | Description                   |
|------|-------------------------------|
| 1    | Alarm No. / Alarms total      |
| 2    | Date and time of alarm        |
| 3    | Alarm code                    |
| 4    | Alarm description             |
| 5    | Alarm-triggered sensor value. |

Alarms can be reset manually, automatically, or automatically on a regular basis.

- Manual reset: when the cause of the alarm is resolved, reset the sound signal using the ALARM button, then press and hold the button  for 3 seconds to complete the reset.
- Automatic reset: when the alarm state is automatically interrupted, the sound signal turns off, and the alarm resets.
- Automatic reset with repetitions: the number of interventions per hour is checked. If this number is less than the set maximum, the alarm is automatically reset. Once the limit is exceeded, only manual reset is possible.

### Caution!

By default, the unit control is done using the TH-Tune controller.

If **pGNE** and/or **BMS** control is performed, TH-Tune must be disabled to avoid the **A010** error (th-Tune offline).

The figure below shows the opening screen of a **pGNE**-controlled unit.

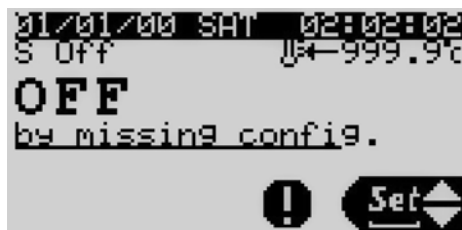

The button  is lit up. Alarm code is displayed when the button is hit.

To continue, do the following:

1. Hit the **Prg** button to enter the main menu. Use the  and  arrow buttons to select the **Unit cfg.** tab and enter it by hitting the  button.

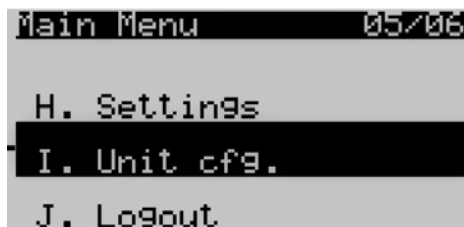

2. In the **Unit cfg.** tab, select the I005 **thTune** parameter and change its value from **Y** to **N**.

```
S Unit cfg.
I005 thTune:      Y
I006 BMS address: 1
I007 Scheduler:  thTUNE
Regulation
I008 Temp.:      SUPPLY
I009 Humidity:   NONE
```



```
S Unit cfg.
I005 thTune:      N
I006 BMS address: 1
I007 Scheduler:  thTUNE
Regulation
I008 Temp.:      SUPPLY
I009 Humidity:   NONE
```

If control is performed via **BMS**, the **I005 Enable thTune management** parameter must be set to 0.

### Alarms

| Alarm code | Alarm description                              | Reset                                 | Action                              |
|------------|--|---------------------------------------|-------------------------------------|
| A000       | Supply temperature probe not working           | Auto reset                            | Stop unit                           |
| A001       | Cooling device alarm                           | User reset                            | Stop cooling                        |
| A002       | Antifreeze alarm by DIN                        | Auto reset until counter (3 in 3600s) | Stop unit, force heating at 100%    |
| A003       | Prototype software                             | Auto reset                            | Stop unit                           |
| A004       | High number of retaining memory writings       | User reset                            | None                                |
| A005       | Error in retaining memory writings             | User reset                            | None                                |
| A006       | Return temperature probe broken not working    | Auto reset                            | Switch to supply regulation         |
| A007       | External temperature probe broken, not working | Auto reset                            | Disable external compensation       |
| A008       | CO <sub>2</sub> air quality probe not working  | Auto reset                            | Disable CO <sub>2</sub> regulation  |
| A009       | Exhaust temperature probe not working          | Auto reset                            | Stop unit                           |
| A010       | th-Tune offline                                | Auto reset                            | Disable room compensation           |
| A011       | Supply temperature out of range                | Auto reset                            | None                                |
| A012       | Supply air flow alarm                          | User reset                            | Stop unit                           |
| A013       | Extract air flow alarm                         | User reset                            | Stop unit                           |
| A014       | Humidifier alarm                               | Auto reset                            | Stop humidifier                     |
| A015       | Humidifier maintenance required                | Auto reset                            | None                                |
| A016       | Extract fan maintenance required               | Auto reset                            | None                                |
| A017       | Supply fan maintenance required                | Auto reset                            | None                                |
| A018       | Reheating coil maintenance required            | Auto reset                            | None                                |
| A019       | Heat recovery maintenance required             | Auto reset                            | None                                |
| A020       | Supply filters alarm                           | Auto reset                            | None                                |
| A021       | th-Tune clock not working                      | Auto reset                            | None                                |
| A022       | th-Tune temperature probe not working          | Auto reset                            | Disable room temperature regulation |
| A023       | th-Tune humidity probe not working             | Auto reset                            | Disable room humidity regulation    |
| A024       | BMS offline                                    | Auto reset                            | None                                |
| A025       | Supply differential pressure probe not working | Auto reset                            | None                                |
| A026       | Return differential pressure probe not working | Auto reset                            | None                                |
| A027       | Fire alarm by digital input                    | User reset                            | Stop unit, force fan at fire speed  |
| A028       | Heating coil water temp.probe not working      | Auto reset                            | Stop unit, force valve at 100% open |

|      |  |                                       |                                     |
|------|--|---------------------------------------|-------------------------------------|
| A029 | Preheating coil water temp.probe not working | Auto reset                            | Stop unit, force valve at 100% open |
| A030 | After preheating coil temp.probe not working | Auto reset                            | Disable preheater                   |
| A031 | Heating device alarm                         | Auto reset until counter (3 in 3600s) | Stop heating                        |
| A032 | Fire alarm by temperature                    | User reset                            | Stop unit, force fan at fire speed  |
| A033 | Antifreeze alarm by heat back water temp.    | Auto reset until counter (3 in 3600s) | Stop unit, force valve at 100% open |
| A034 | Antifreeze alarm by preheat back water temp. | Auto reset until counter (3 in 3600s) | Stop unit, force valve at 100% open |
| A035 | Fans overload alarm                          | Auto reset                            | Stop unit                           |
| A036 | Supply humidity probe not working            | Auto reset                            | Stop humidifier                     |
| A037 | Unit configuration not allowed               | Auto reset                            | Stop unit                           |
| A038 | Supply fan - Offline                         | Auto reset                            | Stop unit                           |
| A039 | Supply fan - Line Fault                      | Auto reset                            | Stop unit                           |
| A040 | Supply fan - Motor blocked                   | Auto reset                            | Stop unit                           |
| A041 | Supply fan - Fire alarm                      | Auto reset                            | Stop unit                           |
| A042 | Supply fan - Uin Low (FW 10)                 | Auto reset                            | Stop unit                           |
| A043 | Supply fan - Uin High (FW 10)                | Auto reset                            | Stop unit                           |
| A044 | Supply fan - UZK low                         | Auto reset                            | Stop unit                           |
| A045 | Supply fan - UZK high                        | Auto reset                            | Stop unit                           |
| A046 | Supply fan - IGBT fault                      | Auto reset                            | Stop unit                           |
| A047 | Supply fan - Earth-GND fault                 | Auto reset                            | Stop unit                           |
| A048 | Supply fan - Peak current error              | Auto reset                            | Stop unit                           |
| A049 | Supply fan - Hall sensor error               | Auto reset                            | Stop unit                           |
| A050 | Supply fan - Offline                         | Auto reset                            | Stop unit                           |
| A051 | Supply fan - Phase Failure                   | User reset                            | Stop unit                           |
| A052 | Supply fan - Motor blocked                   | User reset                            | Stop unit                           |
| A053 | Supply fan - Mains undervolt.                | User reset                            | Stop unit                           |
| A054 | Supply fan - Mains overvoltage               | User reset                            | Stop unit                           |
| A055 | Supply fan - DC-link overvoltage             | User reset                            | Stop unit                           |
| A056 | Supply fan - DC-link undervoltage            | User reset                            | Stop unit                           |
| A057 | Supply fan - Motor blocked                   | User reset                            | Stop unit                           |
| A058 | Supply fan - Intern.circ.overheat            | User reset                            | Stop unit                           |
| A059 | Supply fan - Out stage overheat.             | User reset                            | Stop unit                           |
| A060 | Supply fan - Hall sensor error               | User reset                            | Stop unit                           |
| A061 | Supply fan - Communic. Error                 | User reset                            | Stop unit                           |
| A062 | Supply fan - Generic error                   | User reset                            | Stop unit                           |
| A063 | Supply fan - Out stage high temp.            | Auto reset                            | Stop unit                           |
| A064 | Supply fan - Int.circ.high temp.             | Auto reset                            | Stop unit                           |
| A065 | Supply fan - Motor high temp.                | Auto reset                            | Stop unit                           |
| A066 | Supply fan - DC-link volt.low                | Auto reset                            | Stop unit                           |
| A067 | Supply fan - Lim. mains power                | Auto reset                            | Stop unit                           |
| A068 | Supply fan - Lim. mains current              | Auto reset                            | Stop unit                           |
| A069 | Supply fan - Brake mode                      | Auto reset                            | Stop unit                           |
| A070 | Supply fan - Cable break                     | Auto reset                            | Stop unit                           |
| A071 | Supply fan - Ice protection                  | Auto reset                            | Stop unit                           |
| A072 | Supply fan - Heating: motor stop             | Auto reset                            | Stop unit                           |
| A073 | Supply fan - Speed under limit               | Auto reset                            | Stop unit                           |

|      |                                      |            |  |
|------|--------------------------------------|------------|--|
| A074 | Supply fan - DC-voltage high         | Auto reset | Stop unit                                |
| A075 | Supply fan - Supply volt.high        | Auto reset | Stop unit                                |
| A076 | Supply fan - Line imp. High          | Auto reset | Stop unit                                |
| A077 | Extract fan - Offline                | Auto reset | Stop unit                                |
| A078 | Extract fan - Line Fault             | Auto reset | Stop unit                                |
| A079 | Extract fan - Motor blocked          | Auto reset | Stop unit                                |
| A080 | Extract fan - Fire alarm             | Auto reset | Stop unit                                |
| A081 | Extract fan - Uin Low (FW 10)        | User reset | Stop unit                                |
| A082 | Extract fan - Uin High (FW 10)       | User reset | Stop unit                                |
| A083 | Extract fan - UZK low                | User reset | Stop unit                                |
| A084 | Extract fan - UZK high               | User reset | Stop unit                                |
| A085 | Extract fan - IGBT fault             | User reset | Stop unit                                |
| A086 | Extract fan - Earth-GND fault        | User reset | Stop unit                                |
| A087 | Extract fan - Peak current error     | User reset | Stop unit                                |
| A088 | Extract fan - Hall sensor error      | User reset | Stop unit                                |
| A089 | Extract fan - Offline                | User reset | Stop unit                                |
| A090 | Extract fan - Phase Failure          | User reset | Stop unit                                |
| A091 | Extract fan - Motor blocked          | User reset | Stop unit                                |
| A092 | Extract fan - Mains undervolt.       | User reset | Stop unit                                |
| A093 | Extract fan - Mains overvoltage      | User reset | Stop unit                                |
| A094 | Extract fan - DC-link overvoltage    | User reset | Stop unit                                |
| A095 | Extract fan - DC-link undervoltage   | User reset | Stop unit                                |
| A096 | Extract fan - Motor overheat.        | User reset | Stop unit                                |
| A097 | Extract fan - Intern.circ.overheat   | User reset | Stop unit                                |
| A098 | Extract fan - Out stage overheat.    | User reset | Stop unit                                |
| A099 | Extract fan - Hall sensor error      | User reset | Stop unit                                |
| A100 | Extract fan - Communic. Error        | Auto reset | Stop unit                                |
| A101 | Extract fan - Generic error          | Auto reset | Stop unit                                |
| A102 | Extract fan - Out stage high temp.   | Auto reset | Stop unit                                |
| A103 | Extract fan - Int.circ.high temp.    | Auto reset | Stop unit                                |
| A104 | Extract fan - Motor high temp.       | Auto reset | Stop unit                                |
| A105 | Extract fan - DC-link undervoltage   | Auto reset | Stop unit                                |
| A106 | Extract fan - Lim. mains power       | Auto reset | Stop unit                                |
| A107 | Extract fan - Lim. mains current     | Auto reset | Stop unit                                |
| A108 | Extract fan - Brake mode             | Auto reset | Stop unit                                |
| A109 | Extract fan - Cable break            | Auto reset | Stop unit                                |
| A110 | Extract fan - Ice protection         | Auto reset | Stop unit                                |
| A111 | Extract fan - Heating: motor stop    | Auto reset | Stop unit                                |
| A112 | Extract fan - Speed under limit      | Auto reset | Stop unit                                |
| A113 | Extract fan - DC-voltage high        | Auto reset | Stop unit                                |
| A114 | Extract fan - Supply volt.high       | Auto reset | Stop VOC regulation                      |
| A115 | Extract fan - Line imp. High         | Auto reset | None                                     |
| A404 | VOC air quality probe not working    | Auto reset | None                                     |
| A405 | Supply filter 2 alarm                | Auto reset | Stop Stop humidity check for freecooling |
| A406 | Return filter alarm                  | Auto reset | None                                     |
| A407 | Fresh air humidity probe not working | Auto reset | None                                     |
| A408 | Preheating coil maintenance required | Auto reset | None                                     |

|      |  |            |   |
|------|--|------------|---|
| A412 | IEC humidifier maintenance required    | Auto reset | None  |
| A413 | Cool device maintenance required       | Auto reset | None  |
| A414 | Cool device 2 maintenance required     | Auto reset | None  |
| A415 | Heat device maintenance required       | Auto reset | None  |
| A416 | Heat device 2 maintenance required     | Auto reset | None  |
| A417 | Reverse device maintenance required    | Auto reset | None  |
| A418 | Reverse device 2 maintenance required  | Auto reset | None  |
| A422 | Out of design temperature limits alarm | Auto reset | Open mixer or stop ventilation if not available |
| A429 | Heat exchanger clogged                 | Auto reset | Stopping heat recovery                          |
| A430 | Door switch                            | Auto reset | Stop unit                                       |
| A431 | HEPA 1 filter's sensor fault           | Auto reset | None  |
| A432 | HEPA 2 filter's sensor fault           | Auto reset | None  |
| A433 | Heating pump fault                     | Auto reset | Stop unit                                       |
| A434 | General external fault                 | Auto reset | Stop unit                                       |
| A435 | HEPA 1 filters                         | Auto reset | None  |
| A436 | HEPA 2 filters                         | Auto reset | None  |

### Password control

There are three password levels:

1. Service: read only access to all parameters. By default the password is 0000.
2. Maintenance: read only access to all parameters, but some can be modified. By default the password is 0001.
3. Manufacturer: read/write access to all parameters. By default the password is 0002.

### Configuration selection

If the delivery set includes optional items (e.g. adding a heater), an appropriate configuration must be loaded.

Hit the **Prg** button, select **Unit cfg.** Select **Import** and specify the filename to be loaded. Select **Confirm**; select **Y**.

```

F Unit cfg.
Params Import/Export

I013 Imp/Exp:   EXPORT
I014 Memory:   INTERNAL
I015 Name:     EXPORT_23

I016 Confirm:  N
  
```

Configuration code structure

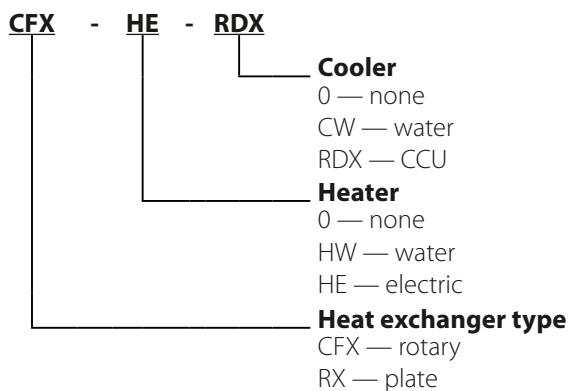

**Standard configuration names**

For configurations equipped with a plate heat exchanger

| Configuration | Filename  |
|---------------|-----------|
| CFX-0-0       | EXPORT_20 |
| CFX-0-CW      | EXPORT_21 |
| CFX-0-RDX     | EXPORT_22 |
| CFX-HW-0      | EXPORT_23 |
| CFX-HE-0      | EXPORT_24 |
| CFX-HW-CW     | EXPORT_25 |
| CFX-HW-RDX    | EXPORT_26 |
| CFX-HE-CW     | EXPORT_27 |
| CFX-HE-RDX    | EXPORT_28 |

For configurations equipped with a rotary heat exchanger

| Configuration | Filename  |
|---------------|-----------|
| RX-0-0        | EXPORT_30 |
| RX-0-CW       | EXPORT_31 |
| RX-0-RDX      | EXPORT_32 |
| RX-HW-0       | EXPORT_33 |
| RX-HE-0       | EXPORT_34 |
| RX-HW-CW      | EXPORT_35 |
| RX-HW-RDX     | EXPORT_36 |
| RX-HE-CW      | EXPORT_37 |
| RX-HE-RDX     | EXPORT_38 |

The automated system can also operate autonomously with no remote controller.  
The control unit has an in-built WEB interface, and supports Modbus and Bacnet protocols through RS485 and Ethernet interfaces.  
The information on protocol settings is specified in the controller's user manual.

The engineering menu enables setting up the control unit operation with pGNE and th-Tune remote controls (one by one or simultaneously)

**ENGINEERING SETTINGS ARE DESCRIBED IN DETAIL IN THE CONTROLLER SOFTWARE USER'S MANUAL.  
CONTACT THE UNIT SUPPLIER TO RECEIVE THE CONTROLLER SOFTWARE USER'S MANUAL.**

### Unit control with the smartphone app

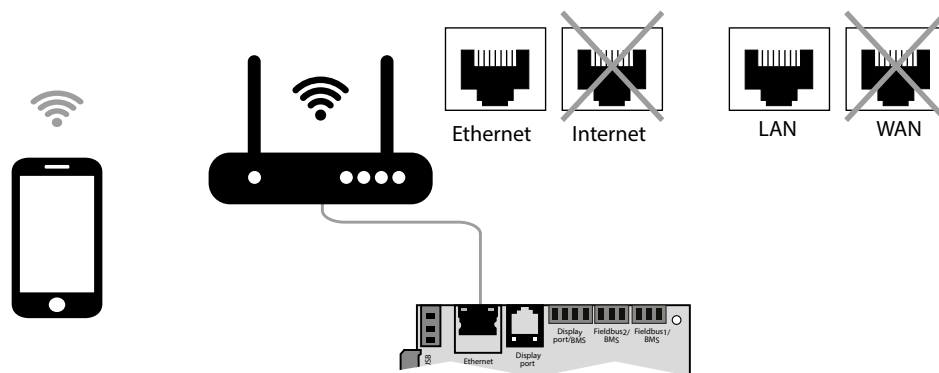

The unit can be controlled via a smartphone or tablet.  
Use a twisted pair cable (4x2x0.51) of Cat5 or higher with 8P8C connectors to connect the router to the controller via Ethernet (LAN).  
Enter the router menu and find the unit's IP address.  
Enter the IP address into the address bar on the smartphone browser.  
It will enable unit control through the smartphone device.  
The control interface is similar to that of the pGNE. control panel.



**VENTS**

